

# BLACKBOX 510R

## ELECTRONICS SET-UP SHEET

Voltage input:	2S LiPo
On resistance (Ω)	0.105
Continuous current (A)	150
Dimensions (mm)	38.5 x 36.9 x 19.5
Weight w/o wires & fan (g)	44
Motor limit	3.5T
BEC	6.0 - 7.4V / 5A

DRIVER: \_\_\_\_\_ EVENT: \_\_\_\_\_ TRACK: \_\_\_\_\_ DATE: \_\_\_\_\_

VEHICLE: \_\_\_\_\_ CONDITIONS: \_\_\_\_\_ BATTERY: \_\_\_\_\_ TEMP: \_\_\_\_\_

### ESC INFO

FIRMWARE:

CAPACITOR TYPE:

FAN:

WIRE SIZE:

### THROTTLE

3A PUNCH CTRL:

3B INIT THROTTLE:

3C DRIVE FREQ:

3D DEAD BAND:

3E CURRENT LIMIT:

### MISC CONTROL

6A RUN MODE:  F/B  F/B/R

6B REVERSE PWR:  25%  50%  75%  100%

6C BATT CUTOFF:  NONE  3.2V/CELL  3.4V/CELL

6D ESC TEMP CUT:  OFF  176F/80C  194F/90C

6E MOT ROTATION:  NORMAL  REVERSE

6F BEC VOLTAGE:  6.0V  7.4V

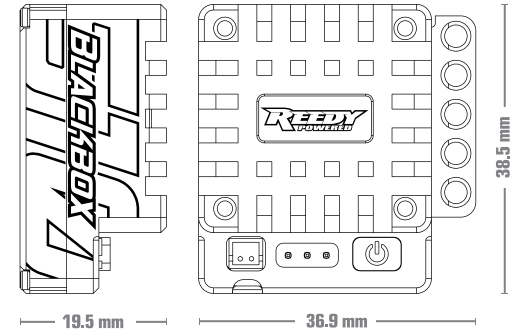

### BRAKE

1A DRAG BRAKE:

1B BRAKE STRNGTH:

1C INIT BRAKE:

1D DRAG FREQ:

1E BRAKE FREQ:

1F BRAKE PUNCH:

### MOTOR POWER

EXPERT

4A BOOST TIMING:

4B BOOST ST RPM:

4C BOOST END RPM:

4D B. TH LIMIT:

4E TURBO TIMING:

4F TURBO ST RPM:

4G TURBO ACT:

4H TURBO DELAY:

4J SLEW RATE:

4K RELEASE RATE:

STANDARD

5A TIMING LEVEL:

### MOTOR SETTINGS

MOTOR:

WIND:

TIMING:

ROTOR:

FDR/ROLLOUT:

TEMPERATURE:

### DYNAMIC DRAGE BRAKE

2A DYNAMIC DRAG:

2B DRAG SW RPM:

2C MAX DDRAG RPM:

2D DRAG REL RATE:

### RADIO SETTINGS

THROTTLE EPA:

BRAKE EPA:

THROTTLE EXPO:

BRAKE EXPO:

NOTES:

---



---



---



---



---