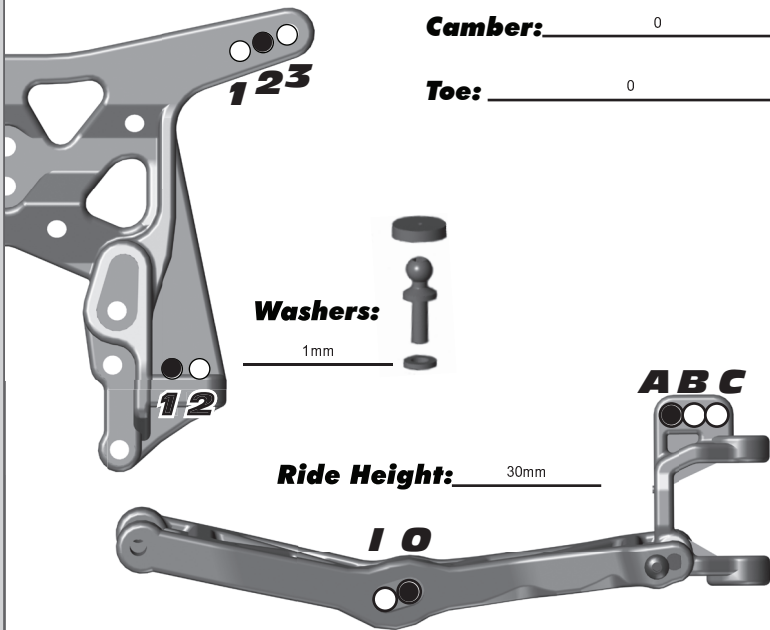
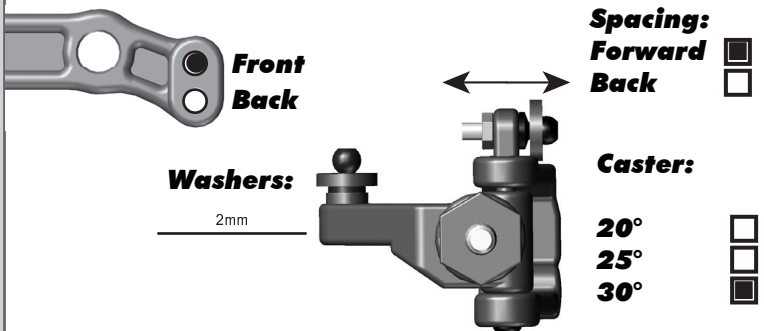
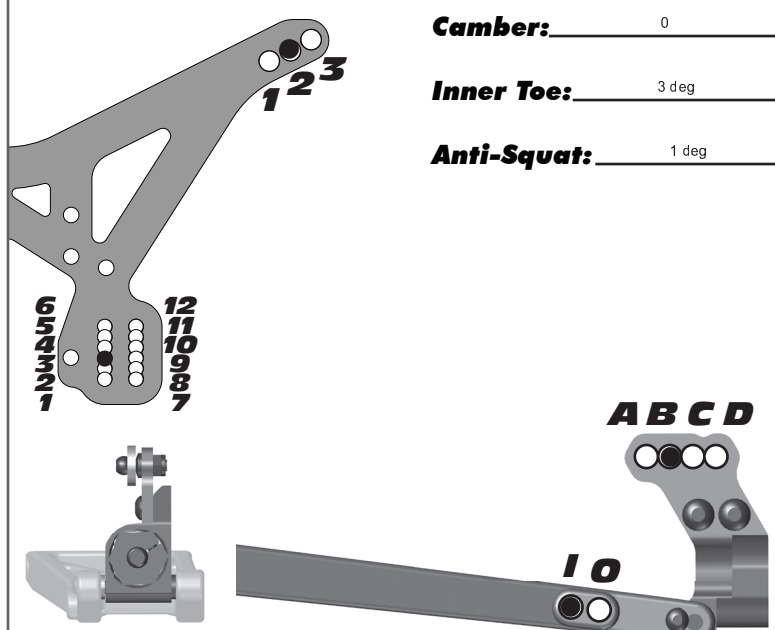

**Front Suspension****Steering Rack:****Rear Suspension**

Reset Forms

**Wheelbase:**

Long

Medium

Short

**Ride Height:** 28mm**Rear Hub Carriers:**

0°

0.5°

1°

1.5°

**Aluminum Hub Tower:**

A

B

C

**Anti Roll Bar:**

None

Black (soft)

Silver (med)

Gold (hard)

**Front Shocks**

**Spring:** Avid Truck Front Red **Piston:** 2 x 1.5 Flat

**Shock Oil:** 32.5 wt **Limiter:** 5

**Rear Shocks**

**Spring:** Associated White **Piston:** 2 x 1.6 Flat

**Shock Oil:** 30 wt **Limiter:** 3

**Electronics / Weight**

**Motor & Wind:** LRP X20 7.5 (Works Team 12.0 Rotor)

**Pinion:** 19 **Spur Gear:** 84

**Batteries:** LRP Saddle Pack

**Battery Placement:** Back

**Ballast Weight:** None

**Chassis Weight:** None

**Radio:** Futaba 4px

**Throttle / Brake e.p.a.:** 100%/74%

**Throttle / Brake expo:** 0

**Servo:** Futaba BLS273SV **Steering Expo:** 0

**ESC:** LRP Flow Works Team

**ESC Settings:** 3.8 Software 7/71/12/13/0/1

**Front Tires**

**Tire:** JConcepts Bar Codes

**Compound:** Orange

**Insert:** JConcepts Blue **Wheel:** JConcepts Mono Hex

**Rear Tires**

**Tire:** JConcepts Bar Codes

**Compound:** Orange

**Insert:** JConcepts Blue **Wheel:** JConcepts Mono Hex

**Drivetrain**

**Slipper:** Team Associated

**2 Pads**  **3 Pads**  **4 Pads**

**Notes:** #7495 - Vented V2 Slipper Hub

**Differentials**

**Ball:**

**Gear:**  tight

**Notes:** tight

**Other**

**Body Type:** JConcepts Finisher

**Wing Type:** Stock **Wing Angle:**

**Race and Vehicle Comments**

**Qualify:** 2 **Main:** A **Finish:** 1 **TQ:**

**Comments:** T4.1 Front Arms and Tower; All Carbon Parts. JConcepts Rear Tower & Bulkhead; JConcepts Narrow Rear Pivots

**Track Info**

<b>Surface:</b>	<b>Traction:</b>	<b>Conditions:</b>	<b>Moisture:</b>
Dirt <input checked="" type="checkbox"/>	Low <input type="checkbox"/>	Grooved <input checked="" type="checkbox"/>	Wet <input type="checkbox"/>
Carpets <input type="checkbox"/>	Med <input type="checkbox"/>	Dusty <input type="checkbox"/>	Damp <input type="checkbox"/>
Astro <input type="checkbox"/>	High <input checked="" type="checkbox"/>	Smooth <input checked="" type="checkbox"/>	Dry <input checked="" type="checkbox"/>
Multi <input type="checkbox"/>		Bumpy <input type="checkbox"/>	
		Hard Pack <input checked="" type="checkbox"/>	
		Loamy <input type="checkbox"/>	