

BLACKBOX 850R

ELECTRONICS SET-UP SHEET

Voltage input:	2S - 6S LiPo
On resistance (Ω)	0.36
Continuous current (A)	150
Dimensions (mm)	56 x 46 x 37
Weight w/o wires & fan (g)	131
Motor limit	4S - 3000kV, 6S - 2400kV
BEC	6.0 - 7.4V / 5A

DRIVER: _____ EVENT: _____ TRACK: _____ DATE: _____

VEHICLE: _____ CONDITIONS: _____ BATTERY: _____ TEMP: _____

ESC INFO

FIRMWARE:

WIRE SIZE:

MOTOR POWER

4A TIMING LEVEL:

MOTOR SETTINGS

MOTOR:

KV RATING:

ROTOR:

FDR/ROLLOUT:

TEMPERATURE:

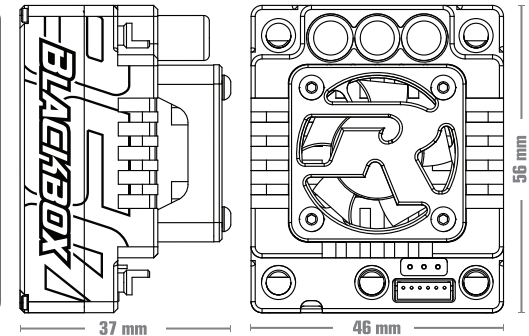

BRAKE

1A DRAG BRAKE:

1B BRAKE STRGTH:

1C INIT BRAKE:

1D BRAKE FREQ:

1E BRAKE PUNCH:

MISC CONTROL

5A RUN MODE: F/B F/B/R

5B REVERSE PWR: 25% 50% 75% 100%

5C BATT CUTOFF: NONE 3.2V/CELL 3.4V/CELL

5D ESC TEMP CUT: OFF 212F/100C

5E MOT ROTATION: NORMAL REVERSE

5F BEC VOLTAGE: 6.0V 7.4V

NOTES:

THROTTLE

3A PUNCH CTRL:

3B DRIVE FREQ:

3C DEAD BAND:

RADIO SETTINGS

THROTTLE EPA:

BRAKE EPA:

THROTTLE EXPO:

BRAKE EXPO:



twitter.com/ReedyPower

[instagram.com/ReedyPower](https://www.instagram.com/ReedyPower)

www.facebook.com/ReedyPower

www.ReedyPower.com

