

For Immediate Release. November

#20540ROL SR7 Hoonicorn, Roller



ELECTRIC ▪ ON ROAD ▪ 1:7 SCALE ▪ 4 WHEEL DRIVE ▪ ROLLER

Team Associated is excited to partner once again with Hoonigan to bring you their world-famous Hoonicorn in 1:7 scale radio control form. Designed from the ground up by our in-house Area 51 Design Works engineers, the Team Associated SR7 chassis is our largest and most powerful RC car ever! This makes it the perfect platform for the Hoonicorn and tire-slating action!



Size comparison: The 1:7 scale SR7 Hoonicorn compared to our 1:14 scale Reflex 14R Hoonicorn



WATCH THE VIDEO!

<https://youtu.be/owOZO-Ev4tE>



HOONIGAN
Trademarks and Trade Dress
used under license to
Associated Electrics, Inc.



Only 2000 with Serial Numbers - Paying Tribute to Ken Block

HIGHLIGHTS



Officially licenced Ford / Hoonigan Mustang Hoonicorn Body Set.



Molded spoiler, tail lights, and rear diffuser for the ultimate handling at high speeds.



Molded '65 Ford Mustang grille and headlight buckets that hold optional LEDs (sold separately).



Molded turbochargers, intake manifold, and realistic window decals for ultimate scale detail.



Molded side skirting with hook and loop for enhanced body mounting.



Licensed American Racing Wheels and belted slick high-traction tires.



Threaded, aluminum oil-filled shocks with adjustable positions.



Monocoque suspension front and rear arm design for precise handling and durability.



A rigid die-formed aluminum chassis with integrated splitter and diffuser for superior aerodynamics at high-speeds.

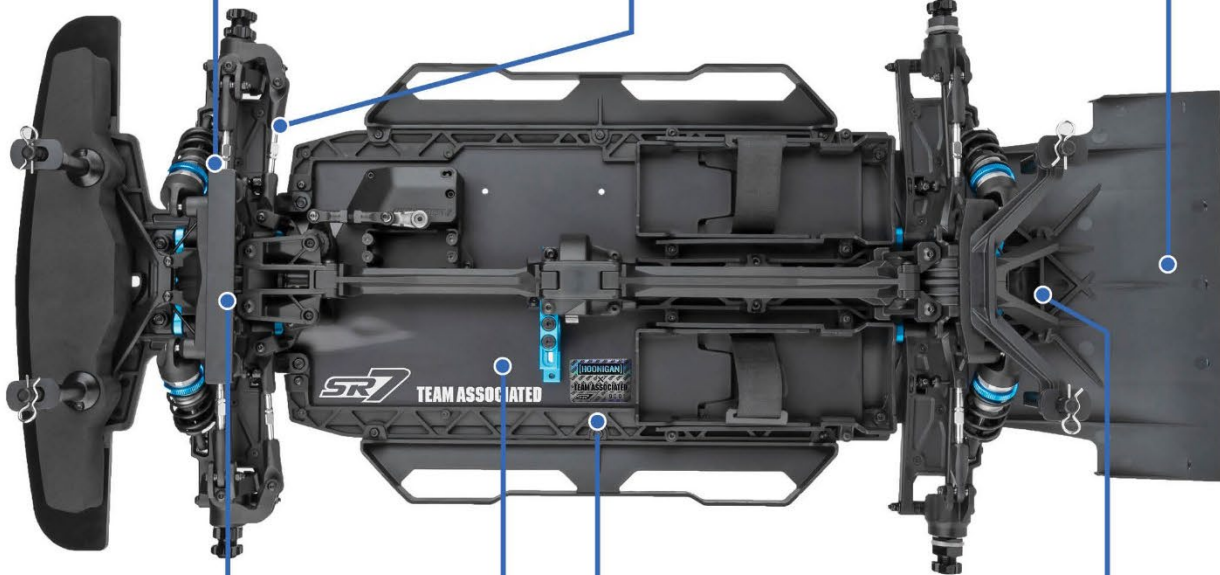

Oil-filled front, center, and rear differentials with sintered powdered metal ring and pinion gears.

Accepts most 1:7 and 1:8 electronic speed controller and motor combinations.

Aluminum arm mounts with adjustable toe, kickup and anti-squat.

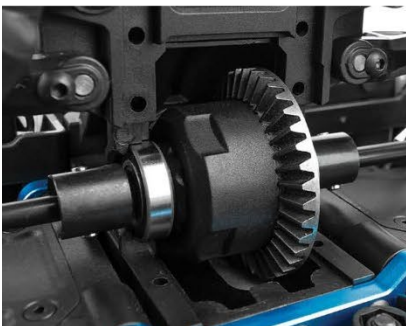

FEATURES

- Officially licensed by Hoonigan and Ford
- Limited Edition and serial numbered
- Enclosed receiver box
- 17mm wheel hexes
- Adjustable front and rear body mounts
- 2-piece adjustable motor mount to accommodate taller gearing
- Dual battery trays with adjustable length and hook and loop strapping
- Heavy-duty CVA joints front and rear
- Integrated chassis bracing for strength and rigidity
- Upper suspension arms with adjustable camber and roll-center
- Aluminum wheel hexes and nuts
- Integrated servo saver
- Anti-roll bars front and rear
- Belted slick tires
- Set up for balanced handling performance out of the box
- Adjustable wheelbase
- Powdered metal servo horn
- Metal ball bearings included

SPECIFICATIONS

Scale	1:7
Power	Electric
Length	711mm (28")
Width	343mm (13.5")
Width (without body)	325mm (12.79")
Weight	Varies
Wheelbase	413mm (16.3")
Transmission Ratio	2.92:1
Chassis	Stamped aluminum
Suspension	Independent front and rear
Internal Gear Ratio	2.92
Type	On-road
Drivetrain	4WD
Tire	4.25" Belted Slick Tire
Gear Pitch	MOD 1
Shock type	Threaded aluminum shock bodies
Ball bearings	26 metal ball bearings
Recommended Environment	Paved surfaces

About the full-size Hoonicorn

The 1965 Ford Mustang Hoonicorn V2 (HvW2 spec) builds upon where the original Hoonicorn left off. Taking the car that starred in Gymkhana SEVEN, the team modified the 410 cubic inch Roush Yates Ford V8 heart of the Hoonicorn to now feature a custom twin turbo setup from Garrett that feeds the boost through a custom Sitzer Dynamics intake manifold. The end result? 1,400 horsepower that's fed through the Sadev all-wheel-drive system with paddle shifters. The whole package sits on a set of American Racing VF503 wheels with super sticky Toyo Proxes R888R tires. Designed from the start to take a car that was already crazy and make it absolutely insane!

Full-Size Hoonicorn Specs

Chassis: 1965 Ford Mustang Hoonicorn RTR (AWD))

Engine: Roush Yates Ford V8, Garrett Twin Turbos

Power Output: 1400hp / 1250ft-lb Torque

Transmission: SADEV Sequential (paddle shifters)

Wheels: American Racing VF503

Tires: Toyo Proxes R888R

ITEMS NEEDED TO COMPLETE

- Two hard-case 2S or 3S RC car LiPo batteries, 35C minimum, with T-type connectors (Reedy 2S #753 or Reedy 3S #755)
- Radio control battery charger suitable for chosen battery, 2-channel recommended (Reedy #27203)
- Motor
- Electronic Speed Control
- 2 channel surface transmitter, 2 channel receiver, and steering servo
- Other helpful items: Silicone Shock Fluid, Silicone Diff Fluid, FT Wrench Set (#1519)

CATALOG INFORMATION

UPC	Part No.	Description	MSRP	MAP	Origin	Qty per Case	Available
784695983311	20540ROL	SR7 Hoonicorn, Roller	\$631.99	\$429.99	China	2	Dec '24

Download all zipped photos here: <https://rc10.com/sr7hoonicornrollerzip/> (6.99MB). Link is active for 30 days.