

For Immediate Release: September 28, 2020

Enduro Gatekeeper Builder's Kit

#40110



ELECTRIC ▪ OFF ROAD ▪ 1:10 SCALE ▪ 4 WHEEL DRIVE ▪ KIT

A rig built to endure. When hitting the trail, you want to do it with performance and confidence. The all-new Enduro Gatekeeper Kit delivers this and more!

Aimed towards the serious RC rock crawler enthusiast, the new Enduro Gatekeeper kit is packed full of performance features that are sure to impress.

What makes the Enduro Gatekeeper kit special? The all-new Gatekeeper Suspension package (GKS™)! This package consists of rear trailing arms that move the shocks forward, allowing a larger window for shock tuning and providing improved weight bias. The trailing arms are paired with a rear anti-roll bar for a more stable and consistent suspension when crawling on the rocks. An adjustable aluminum track bar mount firmly bolted to the chassis rail gives the Enduro GK more reliable and responsive steering without the flex. Our shock mount inserts with multiple mounting positions allow for precise suspension tuning whether it's moving the shocks up, down, forward, or back.

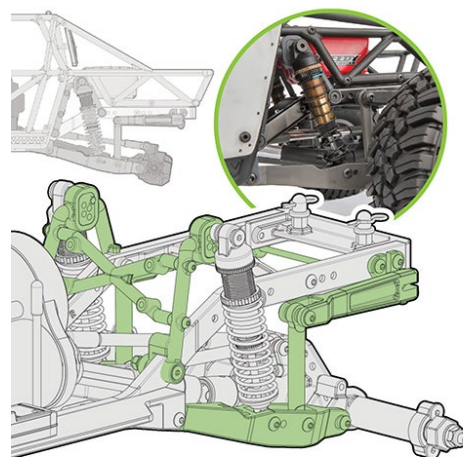

GKS trailing arms in green

The performance doesn't stop there.

The Enduro GK is built on our proven stamped steel C-channel Enduro chassis and retains the same awesome features with the addition of hard plastic components and machined steel pivot balls.

The behind-the-axle (BTA) steering link greatly improves approach angle and front-end clearance, making rough terrain much easier to handle. The Stealth(R) X features the ability to adjust the rear drive ratio independently from the front drive across three levels: stock overdrives the front end 5.7% (included with kit), option 1 provides a one-to-one drive ratio front-to-rear (available separately), and option 2 overdrives the front end 11.83% (included with kit).

Feeding the power to the tires are 3-piece telescopic driveshafts with an extruded aluminum center section, universal front drive axles, and hardened steel ring and pinion gears. With the Enduro GK drivetrain, delivering useful and reliable power will not be an issue.

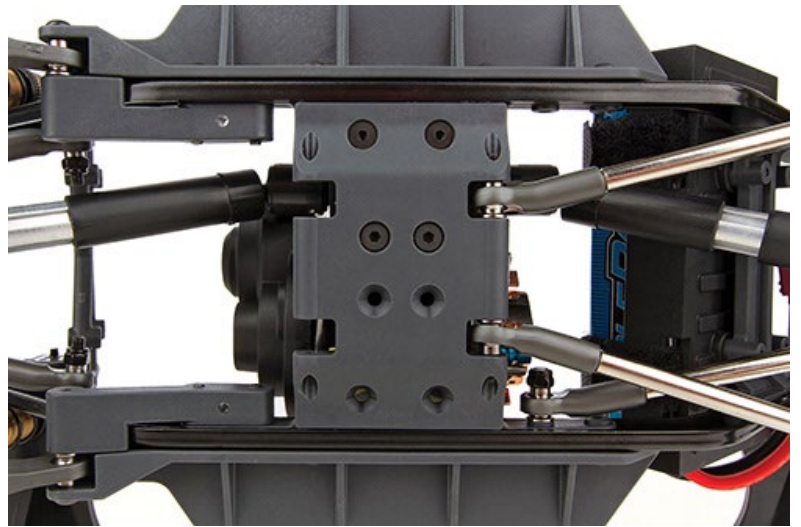

Hard plastics



The Enduro GK kit isn't just all about performance, it's got looks, too. The new Gatekeeper molded cage and polycarbonate panels are the perfect fit for a high-performance rock crawler or trail truck. The included interior with molded driver and passenger heads, along with detailed decal sheet, give the Gatekeeper body awesome scale looks. The removable hinged body mount makes accessing the electronics and working on the chassis a breeze, whether out on the trail or in the garage.

With all these amazing features packed in one box, we know the Enduro Gatekeeper Kit

is a high-performance rock crawling machine that's ready to take on the terrain -- are you?

HIGHLIGHTS

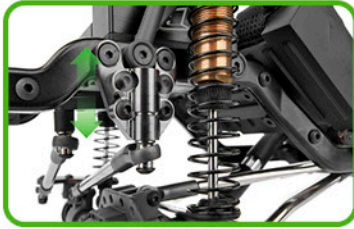

The GKS™ package includes an aluminum track bar mount bolted directly to the steel frame rail, making the front suspension more rigid and flex-free with a more precise steering feel.

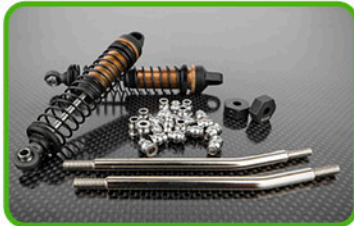

To increase performance we've included several Factory Team parts. Our bronze shocks (4), steel wheel hexes (4), machined metal pivot balls, (30), and lower high-clearance front links (2).

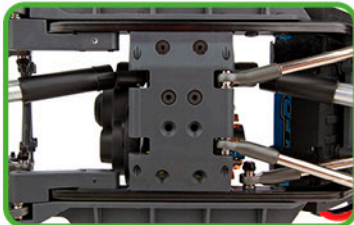

Hard plastic components help improve chassis rigidity and overall durability. As an added bonus, the harder plastic slides over rough surfaces much easier, resulting in fewer chances of getting stuck.



GKS™ shock mount inserts provide drivers with the ability to tune shock angle, droop, and vehicle ride height without affecting spring preload.

ENDURO

WITH TRAILING ARM SUSPENSION

1:10 SCALE ROCK CRAWLER
GATEKEEPER BUILDER'S KIT

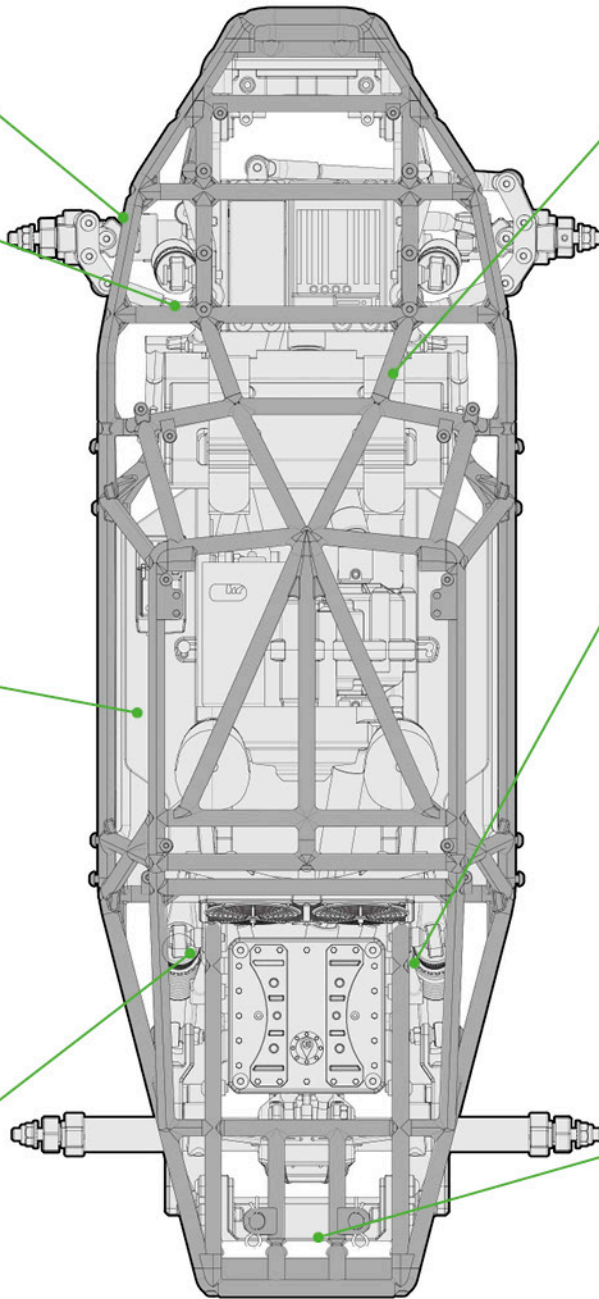

Included is the Gatekeeper injection-molded cage with hinged body mounts and polycarbonate panels. Also included is a large detailed accessory decal sheet to dress up your rig.



At the heart of the Gatekeeper Suspension (GKS™) are the rear trailing arms. This design moves the shocks forward, thus improving weight bias. Because the shock mounting points are farther forward on the lower links and chassis, it allows for a larger window for shock tuning and an optimized anti-roll bar mounting position.



The rear anti-roll bar helps keep the rear suspension stable while driving over rough terrain and improves climbing performance on steep inclines or side hills.

Due to ongoing R&D, photos may not match final kit. Vehicle shown on these pages equipped with items NOT included in kit: Reedy motor, battery, ESC, servo, receiver, wheels, tires, and pinion gear. Assembly and painting required.

MORE FEATURES

- Behind-the-axle (BTA) steering
- Aluminum steering plates
- CMS (Chassis Mounted Steering)
- Steel 25T servo horn
- Integrated servo winch mount
- Threaded aluminum shock bodies
- Stamped steel frame rails
- Aluminum motor plate
- Optimized ball cups for more fluid axle articulation
- Telescopic driveshafts front and rear
- Extruded aluminum driveshaft splines
- One-piece rear axle design
- Splined front axle with adjustable caster
- Universal front drive axles
- Machined input pinion gear
- Metal ring gear
- Machined steel top shaft
- Heavy duty 5mm diameter steel links
- Metal ball bearings

Watch the Video!



<https://youtu.be/4pZHJdf0G-w>

SPECIFICATIONS

Scale	1:10
Power	Electric
Length	varies
Width	varies
Weight	varies
Wheelbase	325mm (12.8")
Transmission Ratio	varies

ITEMS NEEDED TO COMPLETE

- 1:10 scale 540-size electric motor with 48-pitch pinion gear (Reedy Radon 2 Crawler 16T 5-Slot 1850kV Brushed Motor)
- 1:10 scale electronic crawler speed control (#27011 Reedy SC480X Brushed Crawler ESC)
- One 2-cell or 3-cell shorty LiPo battery pack (#758 WolfPack LiPo 3000mAh 30C 7.4V or #759 WolfPack LiPo 3000mAh 30C 11.1V)
- Battery charger (#27203 Reedy 1416-C2L Dual AC/DC Competition Balance Charger)
- 2-channel surface transmitter
- 2-channel receiver
- Steering servo (#27150 Reedy RC4020A Digital HV Aluminum Brushless Crawler Servo)
- Paint for polycarbonate body panels
- Wheels with 12mm hex mounting
- Tires
- Other helpful items needed: FT Body Scissors (#1737), thread-locking compound (#1596), FT Body Reamer (#1499), FT Hex/Nut Driver set (#1519), Hobby Knife, Needle Nose Pliers, Wire Cutters, Soldering Iron, Calipers or Precision Ruler

CATALOG INFORMATION

UPC	Part No.	Description	MAP	MSRP	Available
784695401105	40110	Enduro Gatekeeper Builder's Kit	\$299.99	\$439.99	October 2020

Download all zipped photos here: <https://bit.ly/33brkDj> (4.32 MB). Link is active for 30 days.



21062 Bake Pkwy
Lake Forest CA 92630
www.AssociatedElectrics.com

