

:: 91548 / 91549 Aluminum Rear Hubs for RC10B5 and RC10B5M

Installation:

When installing the hubs on either the B5 or B5M chassis, the laser etching 0° should face the rear shocks.

- RC10B5 rear motor: the etching faces the front of the vehicle, towards the shock
- RC10B5M mid-motor: the etching faces the rear of the vehicle, towards the shock

With the stock hubs, you could run the insert in either the up or down position.

Use a 1mm shim under the ball stud for the DOWN POSITION.

Use a 3mm shim under the ball stud for the UP POSITION.

Stock setup: #2 hole with 3mm shims under the stock (#91047) 6mm ball stud.

NOTE:

If using zero shims, you will need to use a shorter ball stud (#91451 or #91452, 4mm ball studs) than what comes stock on your B5 or B5M. Otherwise, the ball stud could crush the inner bearing.

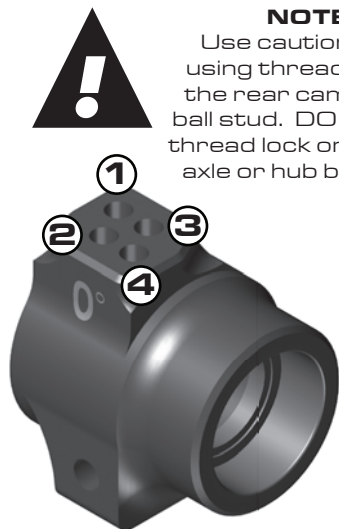

NOTE:

Use caution when using thread lock on the rear camber link ball stud. DO NOT get thread lock on the CVA axle or hub bearings.

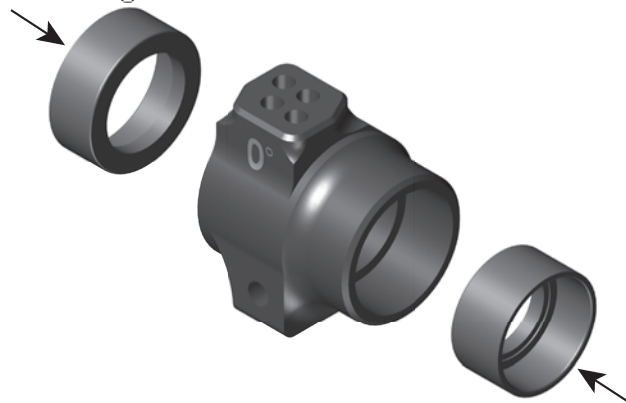
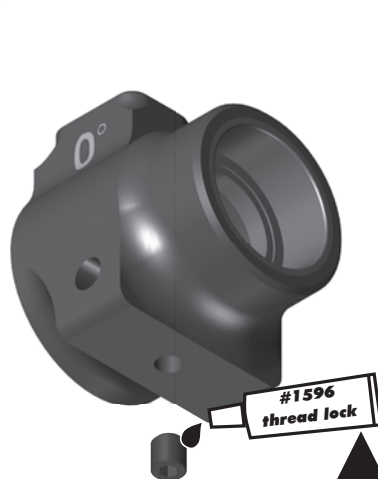

NOTE:
Use thread lock on the included set screw.

NOTE:
The bearing spacers will only fit correctly in the configuration shown.