

# #8400

# RC10L FRONT SUSPENSION KIT

## CONTACTING ASSOCIATED

web: <http://teamassociated.com> or <http://www.rc10.com>  
©1999 by Team Associated

## INTRODUCTION

Associated's hugely popular RC10L series Dynamic Strut front suspension kit includes adjustments for caster, camber, toe in and toe out, and other tuning tricks, all explained in detail in the tuning tips section following the assembly instructions.

## HOW THESE INSTRUCTIONS ARE ORGANIZED

- 1 The line drawings indicate which parts you'll need to take out of the bag for that step. A "1:1" indicates that part is drawn actual size. You can place your part on top to make sure you have the right part.
- 2 We put numbers within black circles to help you link the text instructions with the drawing.
- 3 The instructions in each step are ordered in the order you complete them, so read the words AND follow the pictures.
- 4 When we refer to the left and right sides of the car, we are referring to the driver's point of view from inside the car.

**TEAM**  
**ASSOCIATED**

3585 Cadillac Ave.  
Costa Mesa, CA 92626-1401

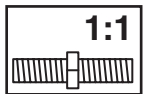

1:1  
8415, qty 2  
upper suspension  
arm turnbuckle

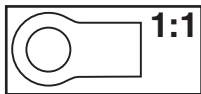

1:1  
8411, qty 2  
upper suspension  
arm eyelet

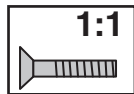

1:1  
8409, qty 4  
4-40 x 1/2"  
shoulder screw,  
blue aluminum



1:1  
8417, qty 4  
pivot ball



8407, qty 2  
0° upper suspension  
arm mount

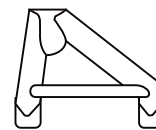

8405, qty 2  
upper suspension  
arm

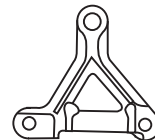

8419, qty 2  
lower suspension  
arm

### ASSEMBLE UPPER SUSPENSION ARM

- 1 Assemble parts #8405, 8415, and 8411.

### ATTACH UPPER ARM MOUNT TO LOWER ARM

- 2 Attach #8407 0° mount to the #8419 lower suspension arm using two #8409 screws. **WARNING!** Screws are difficult to screw in. Turn carefully so you do not strip out the head.

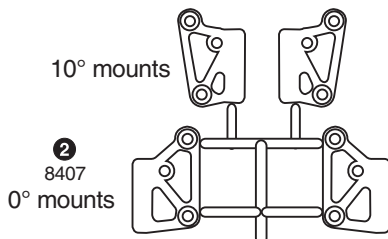

### INSTALLING UPPER AND LOWER PIVOT BALLS

- 3 Before popping in the #8417 pivot balls, make sure there are no burrs inside the pivot ball holes.
  - 4 Pop the #8417 pivot balls into the suspension arms as shown. Make sure that the shoulders of the pivot balls in the lower suspension arms are facing upward and the pivot balls in the upper arm are facing downward as shown. Orient ball to the rounded side of the upper arm as shown.
- 5 Now assemble the right side.

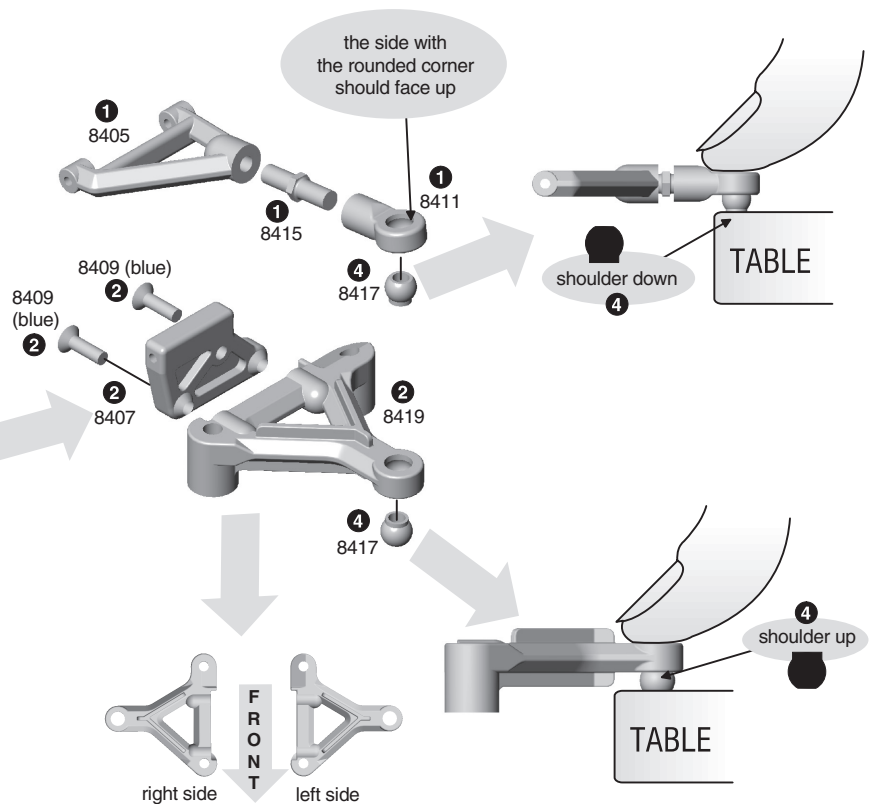

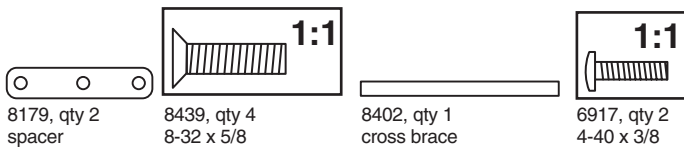

### SUSPENSION ARMS TO CHASSIS

- Slip the #8179 spacer between the suspension arm and the chassis, then bolt on with two #8439 blue aluminum screws from underneath the chassis. Do the other side.

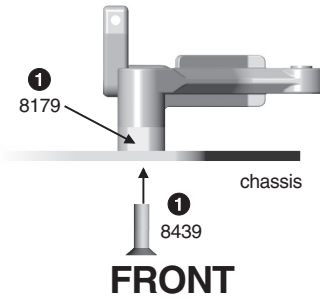

The RC10L3 Oval requires the #8403 cross brace, available separately.

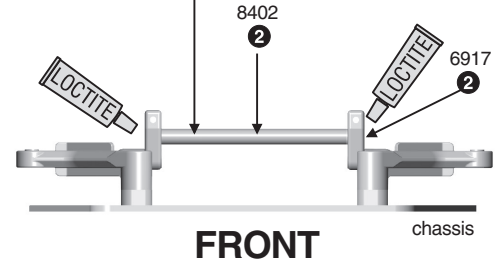

### MOUNT THE CROSS BRACE

- Mount the #8402 cross brace to the front suspension using two #6917 button head screws.

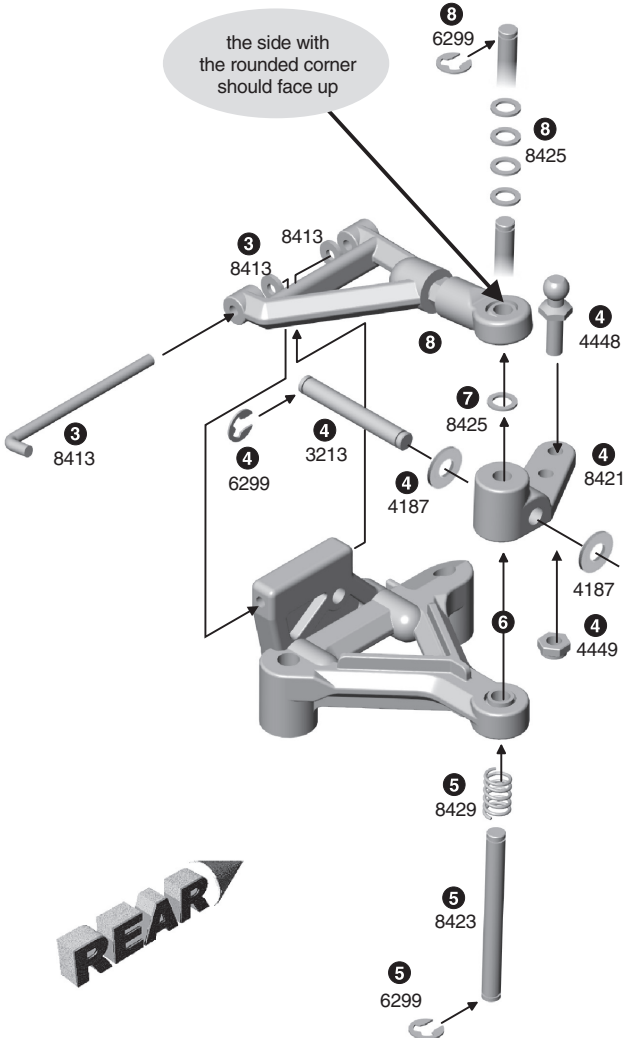
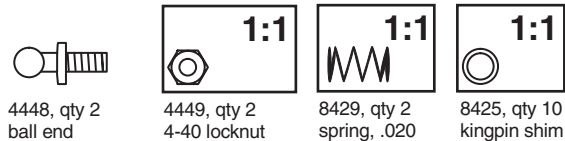
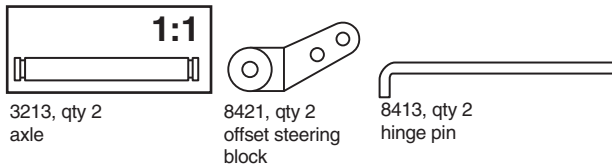
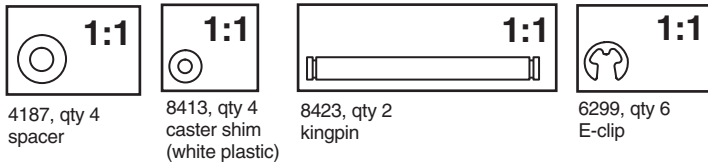

### UPPER ARM TO THE SUSPENSION MOUNT

- Assemble the upper arm assembly to the suspension mount as shown, using the #8413 hinge pin and #8413 shims.

### FINAL FRONT SUSPENSION ASSEMBLY

- Assemble the #8421 steering block as shown using parts #3213, 6299, 4448, 4187, and 4449. Install the ball end into the rear hole.
- Place one #6299 E-clip on the bottom of the #8423 kingpin then slide the #8429 spring over.
- Slide the #8423 kingpin completely through the bottom of the suspension arm and up through the steering block.
- Place one #8425 shim on top of the #8421 steering block.
- Now push the upper arm over the kingpin. Place four #8425 shims over the kingpin and secure with a #6299 E-clip.
- Do the other side.

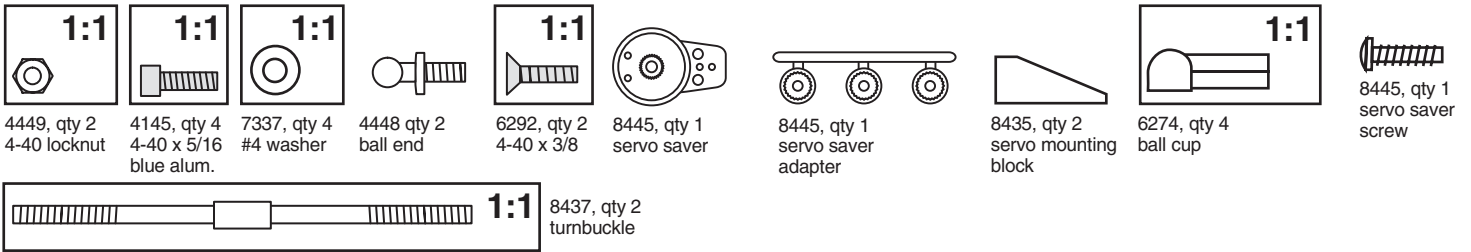

### DRILLING STEERING SERVO BLOCKS

- 1 These holes are recommended for small servos (not recommended).
- 2 These holes are recommended for large servos (recommended).
- 3 Drill two holes with a #43 (or 3/32") drill into the #8435 servo blocks where shown for your servo size.

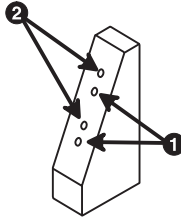

3  
drill into block  
perpendicular to  
the slanted face

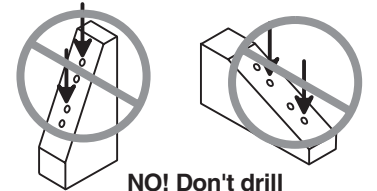

**NO! Don't drill into the block at an angle to the slanted face**

### MOUNTING THE SERVO

- 1 Secure the servo to the #8435 blocks with four #4145 screws and four #7337 #4 washers.

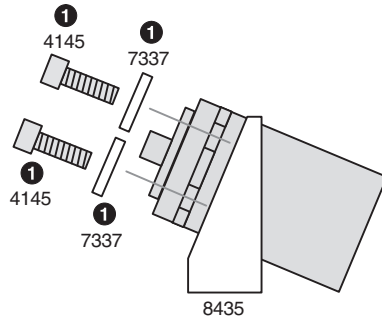

### DRILL SERVO SAVER

- 2 Use your #34 or 3/32" drill bit to carefully drill the two mounting holes for the #4448 ball ends.

### ASSEMBLING THE SERVO SAVER

- 3 Thread two #4448 ball ends into the front side of the #8445 servo saver. Secure the ball ends with the #4449 locknuts. Try the three #8445 adapters on the servo until you find one that fits. Push that adapter into the servo saver.

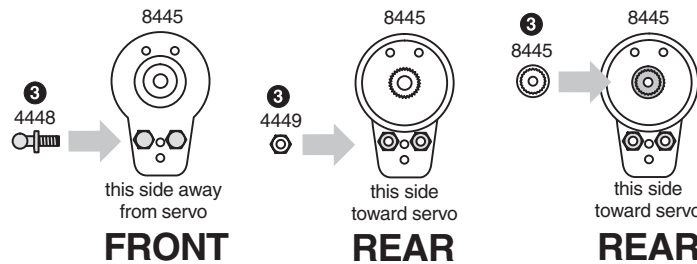

### MOUNTING THE SERVO ASSEMBLY

- 4 Mount the servo saver to the servo with the #3760 screw. **Note:** If you have a metal gear servo, use the stock mounting screw.
- 5 If necessary, drill the chassis holes for your servo mounting blocks with a drill bit. We strongly recommend using 82 deg. countersink (or the tip of a 1/4" drill bit).
- 6 Mount the servo mounting blocks to the chassis with two #6292 screws. If you have more than one set of holes, use the forward holes.

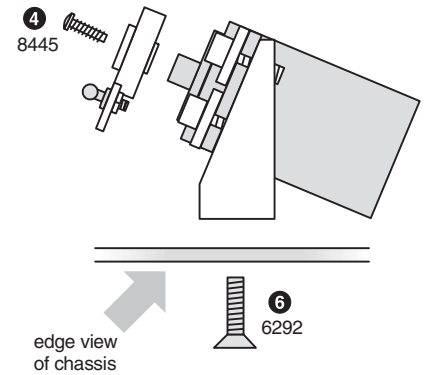

### STEERING LINKAGE

- 1 Install the plastic ball cups onto the steering turnbuckles. The dimension from ball cup to ball cup differs between 1:10 kits. Refer to your manual for the correct dimension.
- 2 Snap one ball cup onto the ball end on the servo saver. Snap the opposite end on as shown. Install both turnbuckles.
- 3 When you are adjusting your turnbuckles, always make sure that the servo saver is pointing straight down.

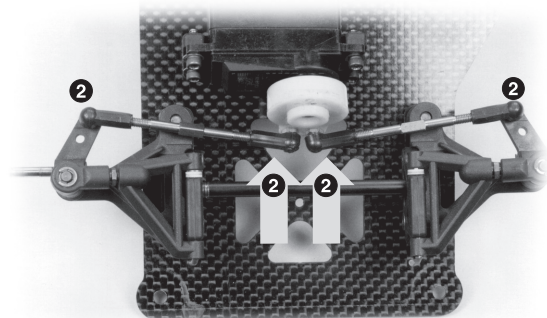
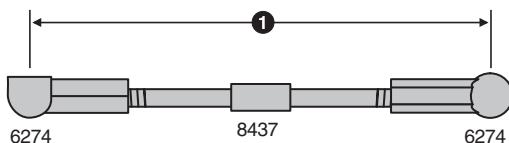

## TUNING & SETUP TIPS

This section explains the adjustments possible to tune your front end for different track conditions.

**CASTER** describes the angle of the kingpin when looked at from the side of the car. As an example, 0° of caster puts the kingpin in a vertical line. Positive caster means the kingpin leans rearward at the top. Increasing the positive caster on your car will slightly increase the steering turning into a corner and slightly decrease steering coming out of the corner. Reducing the positive caster will decrease the amount of steering you have going into a corner and increase the amount of steering you have in the middle of the corner and exiting the same corner.

Your car has adjustable caster in increments of 2°. With the 0° upper arm mounts you can have settings of 0°, 2°, and 4° of positive caster as shown. You change the caster by placement of the PTFE

caster shims on either side of the upper arm mount. The three drawings below show the locations of the caster shims and what the resulting caster settings will be.

For greater amount of caster than moving the upper arm caster shims, you can add the #4127

caster spacers under the suspension arms. They come in 2° increments. Be aware that adding these caster shim spacers will change your ride height.

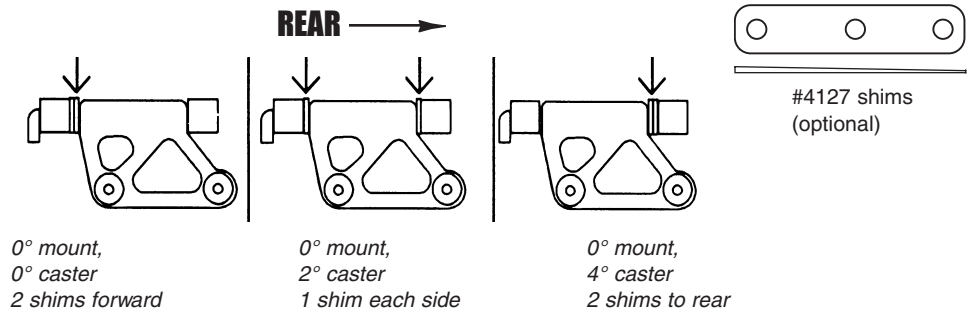

## CASTER CHANGE

The 0° mount is level with the chassis when mounted. The 10° mount is angled 10° in relation to the chassis or lower suspension arm. This angle provides a change in caster during suspension movement. The caster angle will change two degrees during full suspension travel. Your car will steer more aggressively when using this option. The starting or static caster setting is changed in the same manner using the PTFE caster shims. Static caster starts at either 2°, 4°, or 6°. A more detailed example would be a starting caster of 2° will have 0° caster at full suspension travel and a starting caster of 6° will be only 4° at full suspension travel. This setup is recommended for road racing applications, giving you the most aggressive steering possible.

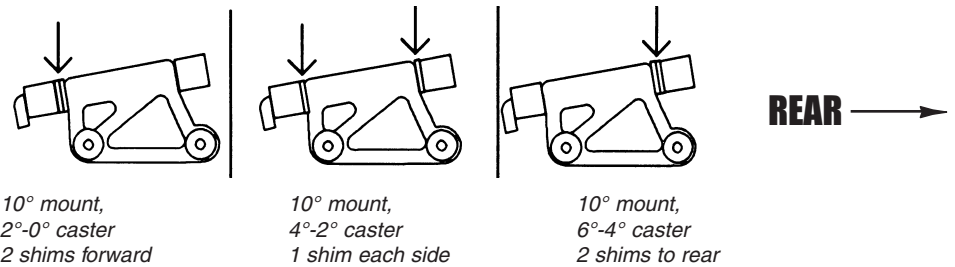

## CAMBER

is a word describing the angle at which the tire and wheel rides relative to the ground when looked at from the front or back. This is one of the most important adjustments on the car. Negative camber means that the tire leans inward at the top, putting it closer to the centerline of the car than the bottom of the tire. Positive camber means just the opposite, the top of the tire is further away from the centerline of the car than the bottom of the tire.

**Excessive** negative camber will decrease traction but increase stability. Positive camber will do the same. We suggest a starting setting of 2° of negative camber. Try to use at least 1 to 2° negative camber at all times and make adjustments to keep your tires wearing flat. This can be adjusted by turning the upper arm turnbuckles in the appropriate direction.

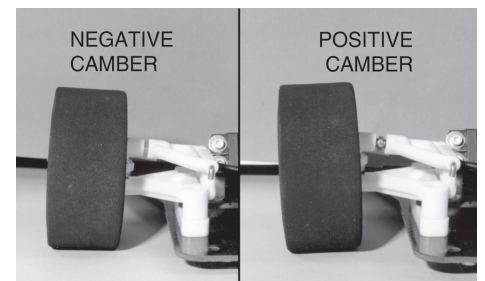

## TOE-IN AND TOE-OUT

is a beneficial adjustment and has a fairly significant effect on the car. Toe-in will help stabilize your car and it also removes a small amount of turn in steering. Toe-out will allow the car to turn in to a corner quicker but will cause instability exiting the corner or on bumpy tracks. Both toe-in and toe-out will scrub speed so try to use as little, of either, as possible. You adjust the toe-in or toe-out by adjusting the length of the steering tie-rod turnbuckles.

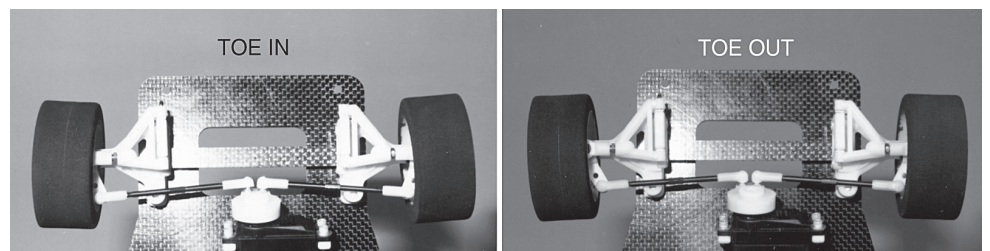

## FRONT SUSPENSION SPRINGS

are available in various wire sizes as listed at right. Changing springs will increase or decrease steering. In general a softer spring (smaller wire diameter) will add steering and a harder spring (larger wire diameter) will decrease steering. Oval racing will normally require a harder spring than road course racing.

|                  |           |                        |
|------------------|-----------|------------------------|
| Part Number      | Wire Size |                        |
| #8433            | (.024")   | Harder (less steering) |
| #8431            | (.022")   | ↑ ↓                    |
| #8429 (kit std.) | (.020")   | ↓                      |
| #8427            | (.018")   | Softer (more steering) |