



#6007 RC10 Classic 40th Anniversary Kit *Limited Edition*

The instruction manual will be in this location when it becomes available.



**Race the car that changed
RC off-road racing forever!**

On December 5, 1984, the All-American-designed Team Associated RC10 was introduced to the RC world. Being the first to take home the gold in both the ROAR National and IFMAR 2WD World Championships, the RC10 secured its place as a legend in RC car history. This year (2024) marks the 40th anniversary of the RC10 and we are proud to offer this special limited 40th Anniversary Edition kit.

Staying true to the original, this anniversary kit features the same race car technology introduced in the 80s. It's that innovation that has kept Team Associated on top of the RC car racing world for the past 40 years.

THE TEAM DOES IT IN THE DIRT

A RACE CAR, NOT A TOY. Sure, you've heard that before. But Team Associated designs and engineers model RACE cars. The new RC10 Classic features fully adjustable four-wheel independent suspension, an aluminum alloy monocoque tub and race-proven hardware throughout. Strength and durability are standard equipment.



RACE-WINNING ENGINEERING

For maximum traction, the RC10 suspension is damped by long throw, fluid-filled racing shocks, using machined alloy cylinders and drill blank shafts for silky smooth action.

Rugged, yet light, the suspension gives you all the adjustability of full-size race buggies. The A-arm/Ball joint design allows precise camber, caster, ride height, and spring rate tuning. Even the adjustable VariLok differential is included, and the updated chassis fits 6-cell NiMH and 2S LiPo battery packs. Exceptional ground clearance and low center of gravity also contribute to the superb balance and performance of the RC10 over all types of terrain.



Independent suspension with coil-over shocks help

smooth out the bumps. Precision molded nylon suspension components can be easily custom color dyed. A-Arm/Ball joint design permits static camber, camber rise, caster, ride height and spring rate tuning to suit every type of track.



Full race rear suspension includes durable dogbone and stub axle drivetrain with pinned modular wheels. Quick release knockoff design provides fast, accurate alignment. Low profile gearbox uses VariLok adjustable diff and is protected by an integrated motor/heat sink.

CHASSIS FEATURES

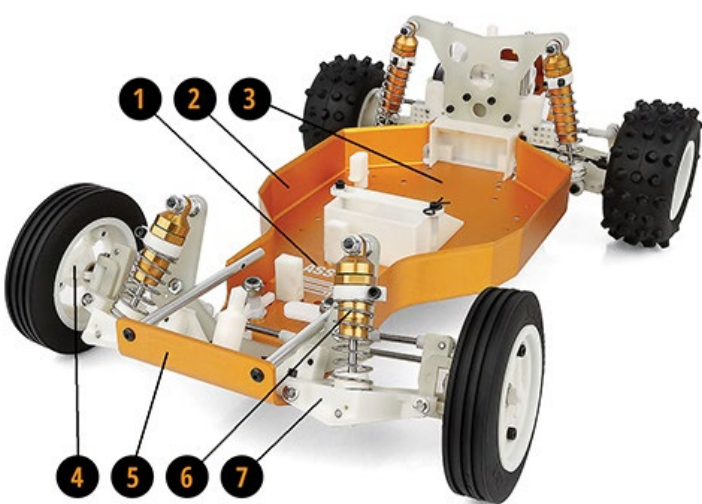

1. Factory etched with iconic AE logo and Team Associated Race font!
2. T6 aircraft aluminum monocoque tub
3. The RC10 Classic is designed accept fit 6-cell NiMH and 2S LiPo battery packs
4. Competition modular wheels
5. Front skid plate
6. Adjustable custom aluminum racing shocks
7. Fully adjustable 4-wheel independent suspension

The 40th Anniversary chassis will be distinguished from other gold tub chassis in the following ways.

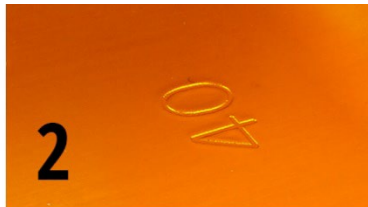

1. "Team Associated" laser-etched in chassis.
2. "40" stamped below transmission.
3. Official RC10 foil decal with listed kit number.
4. QR code to download and view the instruction manual.

In addition, the box becomes a stand to display your limited edition:



GET THE JUMP ON THE COMPETITION.

Go RC off-road racing with the leaders. The World Champion RC10 is available now and ready for competition. Complete RC10 kits are readily

available through model car racing's most extensive dealer network. Take the challenge and build yourself a winner. Team Associated's RC10.

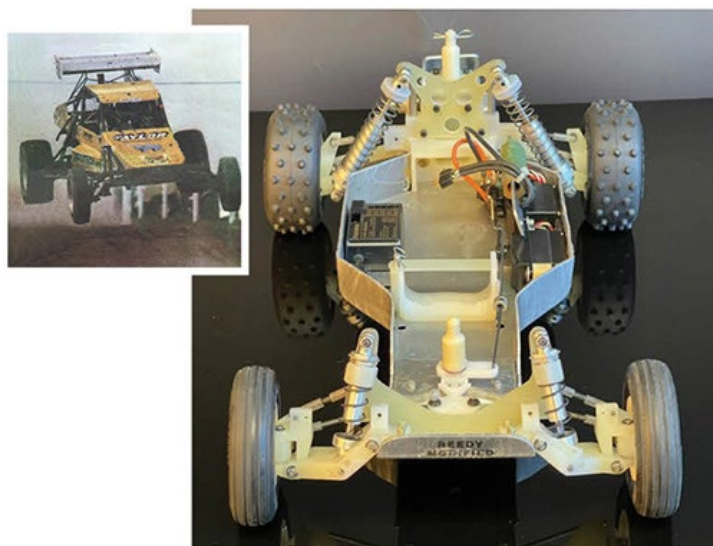

Above: the prototype RC10, right, and the full-size off-road buggy that inspired founder Roger Curtis for the design and box art.

ITEMS NEEDED TO COMPLETE

- 6-cell NiMH or 2S LiPo for radio-controlled car
- Radio control battery charger
- 1:10 scale radio control electronic speed control
- 1:10 scale 540-size electric RC car motor
- 2-channel RC surface transmitter and its batteries
- 2-channel receiver
- Pinion gear
- Paint for the body
- Steering servo
- Recommended: Glue for tires and wheels

SPECIFICATIONS

Scale	1:10
Power	Electric
Length	381mm (15")
Width	226.8mm (8.93")
Weight	Varies
Wheelbase	267.7mm (10.54")
Transmission Ratio	2.6:1

Due to ongoing R&D, photos may not match final kit. Vehicle shown on these pages equipped with items NOT included in kit: Reedy motor, battery, ESC, servo, receiver, and pinion gear. Assembly and painting required.

A LEGEND IS BORN

Many of the people involved in the design of the RC10 were out there testing and driving the cars themselves, even Mike Reedy and Gene Husting. Here are a few:

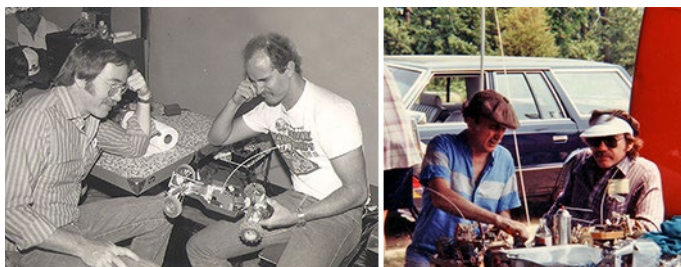

L to R: Roger Curtis, Curtis Husting, Mike Reedy



L to R: Roger Curtis, Gene Husting, unknown, Jay Halsey, Jim Halsey, Mike Reedy

MAKING CHAMPIONS



In 1985, Jay Halsey, above, took home the win at the very first 2WD IFMAR Off-Road World

Championship in Del Mar, California. Since then, there have been many National and World Champions. In fact, every iteration of the RC10 platform has won at least one IFMAR World Champion title. Here are a few others who won with the RC10 platform:



L to R: Mark Pavidis, Masami Hirotsuka



L to R: Masami Hirotsuka, Brian Kinwald



L to R: Billy Easton, Neil Cragg, Spencer Rivkin

IN THE MOVIES

The RC10 made its feature film debut in 1988 with *The Dead Pool*, starring Clint Eastwood.

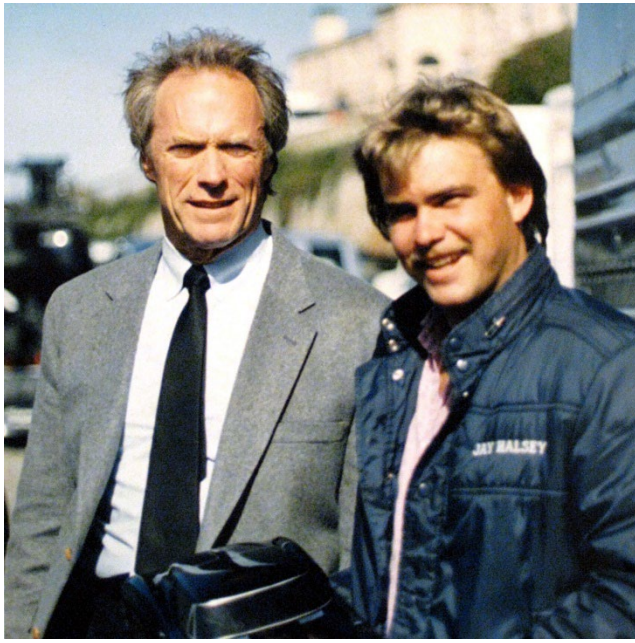

IFMAR World Champion Jay Halsey (right) on the set of *The Dead Pool* with star Clint Eastwood



Custom-built RC10 that was driven by Jay Halsey for the film *The Dead Pool*.

MAKING HISTORY

On August 11, 2015, the RC10 made history by earning a spot at the Smithsonian National Museum of American History in Washington D.C.



21062 Bake Pkwy
Lake Forest CA 92630
www.AssociatedElectrics.com

This file: <https://rc10.com/rc1040hist/>

Main page: <https://rc10.com/rc1040inpr/>