

PROTECTION FUNCTIONS

LiPo Low Voltage Cutoff Protection

If the voltage of the LiPo battery falls below the minimum threshold for more than two seconds, the ESC will cut off the output power and the LED will blink red. The ESC will not operate as long as the voltage remains below 3.2V per cell (3S=9.6V, 4S=12.8V).

Note: The Low Voltage Cutoff Protection works only when the ESC is set in LiPo mode. If you fail to switch the ESC to NiMH mode when using a NiMH battery, the ESC will continue to activate when it reaches the minimum voltage threshold.

Thermal Protection

If the temperature of the ESC exceeds the maximum threshold for more than five seconds, the ESC will cut off the output power and the LED will flash green.

Throttle Signal Loss Protection

If the throttle signal is lost for more than 0.2 seconds, the ESC will cut off the output power.

ALERTS

Abnormal Input Voltage

If the input voltage is below the normal range when powered ON, the ESC will emit a “beep-beep-” tone at one second intervals.

Abnormal Throttle Signal

When the ESC does not detect a normal throttle signal, the LED will flash.

WARRANTY

Your Reedy Electronic Speed Control is warranted to the original purchaser for 30 days from the date of purchase, verified by the sales receipt, against defects in material and workmanship. Product that has been mishandled, abused, used incorrectly, used for an application other than intended or damaged by the user is not covered under warranty. Associated Electrics Inc. is not liable for any loss or damage, whether direct or indirect, incidental or consequential, or from any special situation, arising from the use, misuse, or abuse of this product.



SC1000-BL BRUSHLESS ESC OWNER'S MANUAL

#29181

Congratulations on your purchase of the Reedy SC1000-BL Brushless Electronic Speed Control (ESC). The latest electronics technology along with the design and engineering experience that is responsible for 29 World Championship titles has been incorporated into its design.

The Reedy SC1000-BL Brushless ESC is splash-proof for maximum durability. Its robust design installs in most 1/8 buggies, truggies and short course trucks. When paired with Reedy brushless motors, a potent combination of power and efficiency is created resulting in quick acceleration, high top speeds, generous run times, and more fun!

Please read the following instructions before installing and operating your ESC.

TROUBLESHOOTING		
Problem	Cause	Solution
After powering ON the ESC, the motor does not work and no sound is emitted	The connections between battery pack and ESC are incorrect	Check the power connections
		Replace the connectors
After powering ON the ESC, the motor does not work but emits a “beep-beep” alert tone at one second intervals	Input voltage is too high or too low	Check the voltage of the battery pack
After powering ON the ESC, the motor does not work but emits a “beep” alert tone at one second intervals and the red LED is illuminated	Abnormal throttle signal	Be sure the transmitter is working properly and that the batteries are charged
		Check the receiver plug connection
After powering ON the ESC, the motor does not work and the red LED blinks very quickly	The neutral point of the throttle channel has changed	Re-calibrate the throttle range of the ESC
		Adjust the throttle trim to change the neutral point
The motor runs in the opposite direction	The wire connections between the ESC and the motor need to be changed	Swap any two wire connections between the ESC and the motor
The motor suddenly stops running while driving the vehicle	The throttle signal from the transmitter has been lost	Be sure the transmitter is working properly and that the batteries are charged
		Be sure that the ESC is plugged into the receiver correctly
	The ESC has entered Low Voltage Protection mode	Re-charge the battery/install a fully charged battery
	The ESC has entered Thermal Protection mode	Allow the ESC to cool down
Intermittent operation or random stopping/starting	Poor connections	Verify that the battery pack, receiver, and motor connections are correct
	Strong electromagnetic interference	Move to another area to operate the vehicle or wait until the interference has subsided

FEATURES

- LiPo low-voltage cutoff protection
- LiPo cell auto-detect
- Fully proportional brakes
- Durable case with aluminum heat sink
- Pre-wired cooling fan
- Water-resistant
- Heavy duty silicone wires
- Low-resistance T-plug connector
- 4.0mm motor connectors

SPECIFICATIONS

Cells	3-4 LiPo, 9-12 NiMH
Suggested Applications	1/8 Buggy, Truggy, SCT
Resistance (Ω)	0.0005 ohm
Brakes	Proportional
Motor Limit	3S LiPo, 9-10 NiMH
	4S LiPo, 11-12 NiMH
Reversible	Yes
Low Voltage Cutoff	Yes, w/Cell Auto-Detect
Dimensions (mm)	59.5 x 48.0 x 42.0
Weight	173.0g
Power Wires	12-Gauge Silicone
Connector	Battery/T-Plug
	Motor/4.0mm sockets

SAFETY PRECAUTIONS

This product is a sophisticated hobby product and not a toy. It must be operated with caution and common sense and requires some basic mechanical ability. Failure to operate this product in a safe and responsible manner could result in injury or damage to the product or property. This product is not intended to be used by children without direct adult supervision. It is essential to read and follow all instructions and warnings found in this manual prior to installation, set up, and use, in order for the product to operate properly and to avoid damage or injury.

INSTALLATION

- Mount your ESC and switch securely using high quality double-sided tape.
- Install your ESC in a position that allows easy access to all connectors.
- Plug the ESC's receiver wire into the receiver (refer to radio manufacturer's manual)
- To prevent radio interference, arrange ESC wiring so that it is not in close proximity to the receiver antenna wire.
- Connect the three motor leads exiting the ESC to the three leads exiting your motor. If the motor runs backwards when giving it forward throttle, reverse any two motor leads. The motor will now run the desired direction.
- Always power ON your transmitter before the ESC and power OFF the ESC before the transmitter.

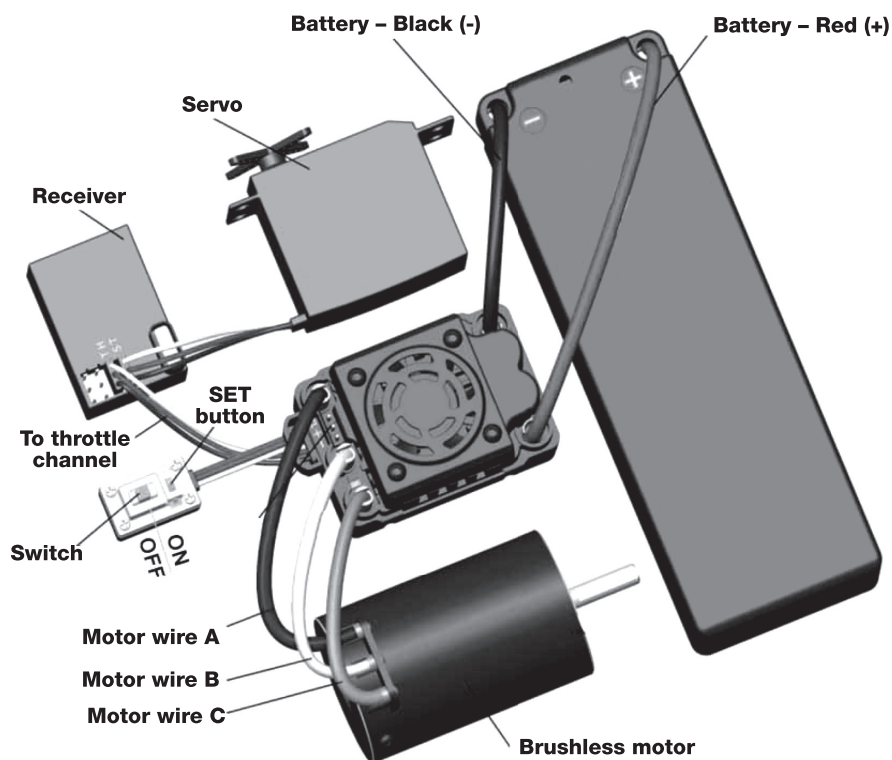

SWITCHING BETWEEN LIPO AND NIMH BATTERY MODES

A choice of either LiPo mode or NiMH mode activates the low voltage cutoff point. This is particularly important when using LiPo batteries that should not, for performance and safety reasons, be discharged below 3.2V per cell. In LiPo mode, the ESC detects whether you are using 3 or 4 cells and adjusts the cutoff accordingly.

The color of the LED at neutral throttle indicates which mode the ESC is currently in. When in LiPo mode, the LED will be green. When in NiMH mode, the LED will be red. Regardless of which mode the ESC is in, the LED will always blink red when the Low Voltage Cutoff Protection is activated and flash green when the Thermal Protection is activated.

LiPo-->NiMH: With the transmitter and ESC powered ON and the throttle trigger in the neutral position, press and hold the SET button (approximately two seconds) until the green LED begins to flash. Continue to hold the SET button (approximately four more seconds) until the LED begins to flash red indicating a successful switch. Now release the SET button. The red LED will continue to flash (approximately four seconds) and then remain solid red. The ESC has successfully been switched from LiPo mode to NiMH mode and the ESC is ready to use.

NiMH-->LiPo: With the transmitter and ESC powered ON and the throttle trigger in the neutral position, press and hold the SET button (approximately two seconds) until the red LED begins to flash. Continue to hold the SET button (approximately four more seconds) until the LED begins to flash green indicating a successful switch. Now release the SET button. The green LED will continue to flash (approximately four seconds) and then remain solid green. The ESC has successfully been switched from NiMH mode to LiPo mode and the ESC is ready to use.

Note: Continuing to press the SET button after successfully switching modes will switch the mode again. Releasing the SET button after the appropriate flashing LED color confirms the mode selection.

WARNING: FAILURE TO SELECT LIPO MODE WHEN USING LIPO BATTERIES MAY RESULT IN PERMANENT DAMAGE TO THE BATTERY AND/OR FIRE.

THROTTLE CALIBRATION

Each time you install a new ESC, a new transmitter, or after changing the neutral position, ATV or EPA parameters on your radio, the throttle range must be re-calibrated. The ESC will not work properly until it has been calibrated.

There are three points that need to be set – maximum throttle, maximum brake, and the neutral point. The following steps and accompanying diagram illustrate the procedure.

Note: ESCs that came installed in an RTR vehicle have already been calibrated and are ready to use.

1. Set your radio's throttle and brake EPA/ATV to 100% and your throttle trim to neutral, and then turn on your transmitter.
2. Press and hold the SET button while powering ON the ESC. When the LED begins to flash, release the SET button immediately.
3. With the throttle trigger at neutral, press the SET button to save the neutral position verified by one flash of the LED.
4. Move the throttle trigger to the full throttle position and press the SET button to save the full throttle position verified by two flashes of the LED.
5. Move the throttle trigger to the maximum brake position and press the SET button to save the maximum brake position verified by three flashes of the LED.
6. Return the throttle trigger to the neutral position. After three seconds, the ESC will automatically exit the calibration procedure and the ESC is ready to use.

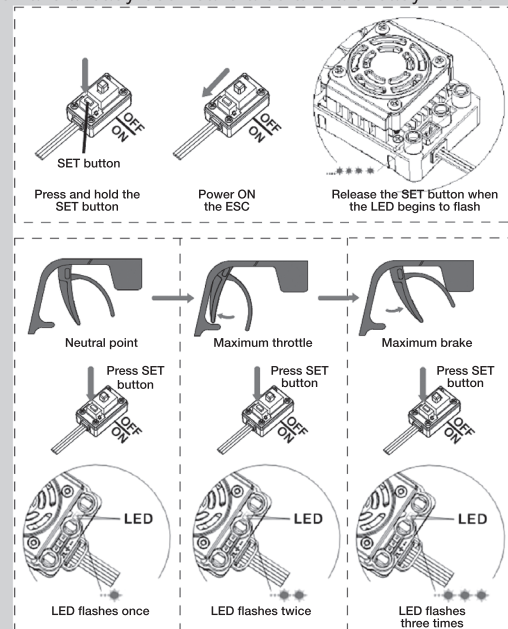

Green LED = LiPo mode
Red LED = NiMH mode