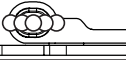
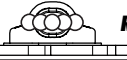
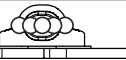
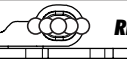

Track Info

Size: Small Medium Large XL
 Surface: Carpet Asphalt
 Indoor Outdoor
 Traction: Low Medium
 High Wet
 Condition: Bumpy Smooth
 Temperature: Ambient Track

Roll Centers

FF  RF 
 Shim: _____ Shim: _____
 FR  RR 
 Shim: _____ Shim: _____

Notes

Front	Transmission	Rear
<input type="checkbox"/>	Solid Axle	<input type="checkbox"/>
<input type="checkbox"/>	Gear Diff	<input type="checkbox"/>
	Fluid	
Mass w/Fluid		

Spur: _____ Pinion: _____ FDR: _____

Notes

Front	Shocks	Rear
	Spring	
	Piston	
	Fluid	
	Rebound	
	Stroke	
	Anti-Roll Bar	

Notes

Body & Wing

Body: _____ Position: _____
 Wing: _____ Position: _____





Notes

Electronics

Motor: _____ Timing: _____
 Battery: _____ Mass: _____
 ESC: _____ Settings: _____
 Radio: _____ Servo: _____
 Turn Circle: _____ STR Expo: _____
 Brake Expo: _____ THR Expo: _____

Notes

Tires

Tires: _____
 Insert: _____ Wheel: _____
 Tire Diameter (F/R): _____
 Additive (F/R): _____
 Additive Timing: _____
 Left FR  Right FR  Left RR  Right RR 

Notes

:: Team Associated

Driver: _____ Date: _____
 Track: _____ Event: _____
 Qualify: _____ Best Lap Time: _____ Main: _____ Finish: _____



Front

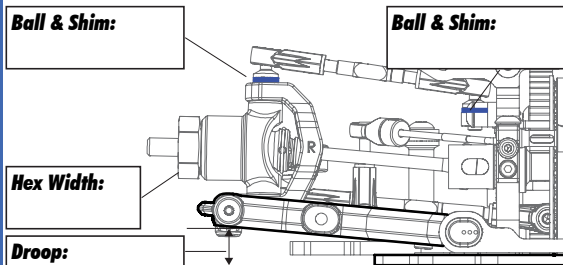
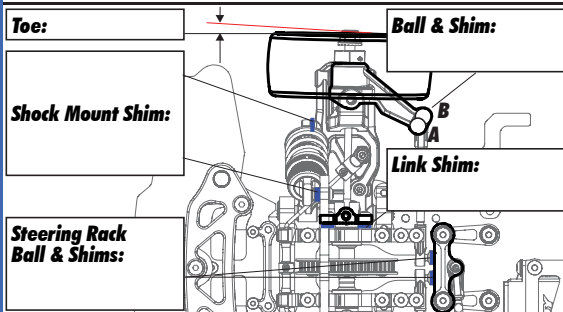
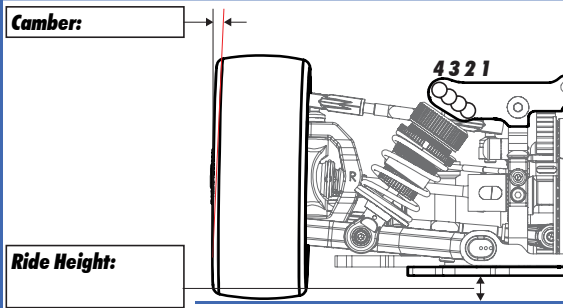

Notes

Inline Flex Mount

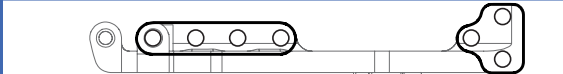

Pitch Control System

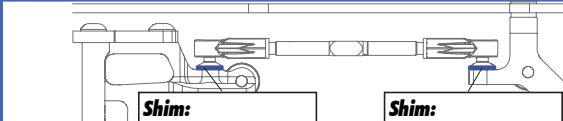

Notes

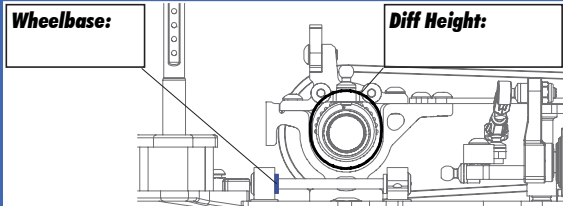

Notes

Rear

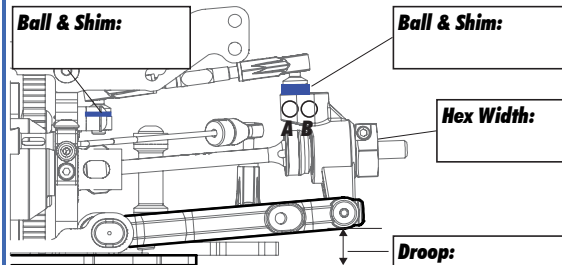
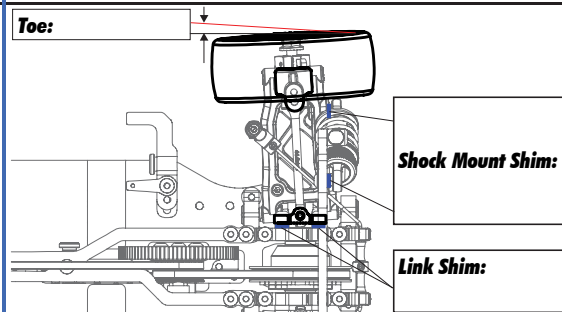
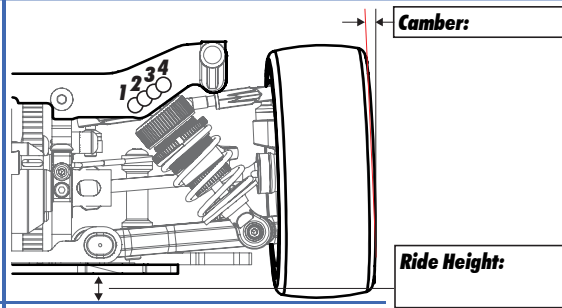

Notes

Dynamic Toe Control

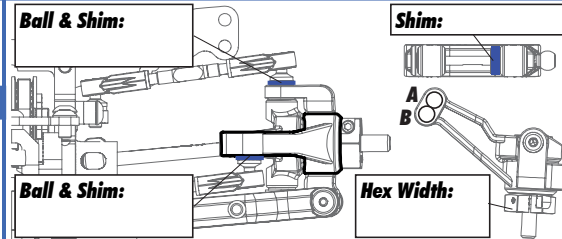

Notes

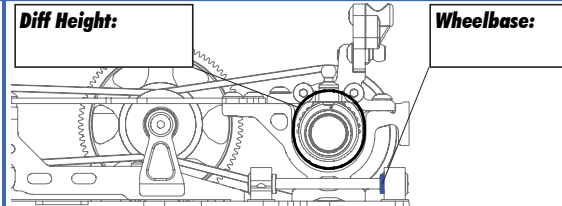

Notes

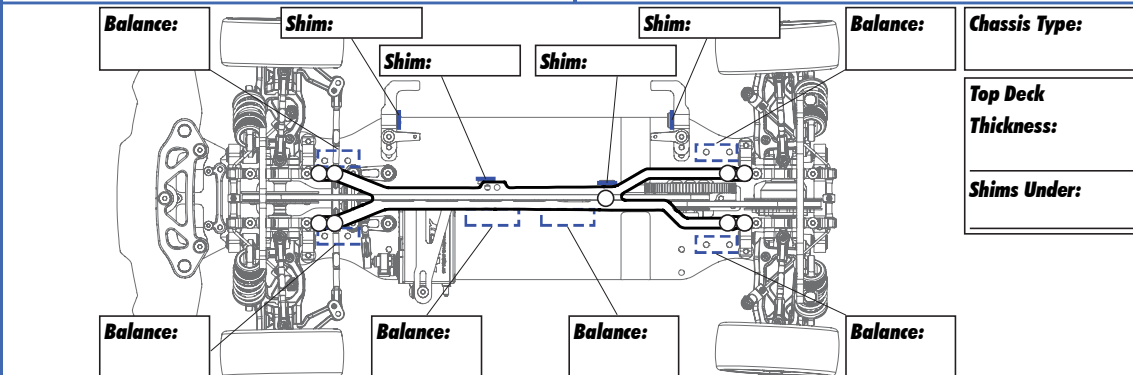

PetitRC: