

Track Info

Size: Small Medium Large XL
Surface: Carpet Asphalt
 Indoor Outdoor
Traction: Low Medium
 High Wet
Condition: Bumpy Smooth
Temperature: Ambient 75F Track NA

Driver: Rick Hohwart
Track: Steel City Speedway
Quality: 2

Date: 5/5/19
Event: CTS4
Main: A **Finish:** 2



Roll Centers

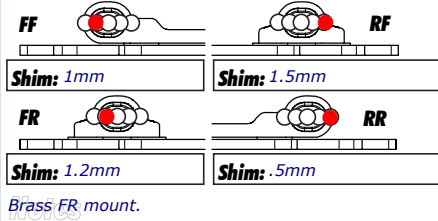

Transmission

Front Solid Axle
 Gear Diff
 NA Fluid 7K
 NA Mass w/Fluid 22.7g
Spur: 87 **Pinion:** 24 **FDR:** 7.25:1

Notes

Front	Shocks	Rear
SMJ pink	Spring	SMJ pink
PSD	Piston	PSD
AE 25	Fluid	AE 25
0	Rebound	0
9.5mm	Stroke	9.5mm
1.2mm	Anti-Roll Bar	1.3mm

Notes

Body & Wing

Body: PF Type-S Pro-Lite **Position:** +8mm
Wing: PF TS18 **Position:** neutral
 AE body height adjusters.

Electronics

Motor: Reedy 540-M3 4.5 **Timing:** 30 deg
Battery: Reedy 6000mAh **Mass:** 276g
ESC: Blackbox 510 **Settings:** NA
Radio: Sanwa **Servo:** Reedy RS1306
Turn Circle: 28 deg **STR Expo:** 0
Brake Expo: 0 **THR Expo:** 0
 Motor & ESC fans wired directly to battery.

Tires

Tires: Elexis 36
Insert: NA **Wheel:** NA
Tire Diameter (F/R): NA
Additive (F/R): FX2
Additive Timing: 10 min.

Notes

:: Team Associated

Front

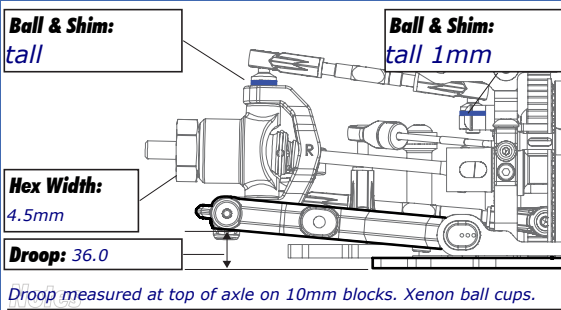
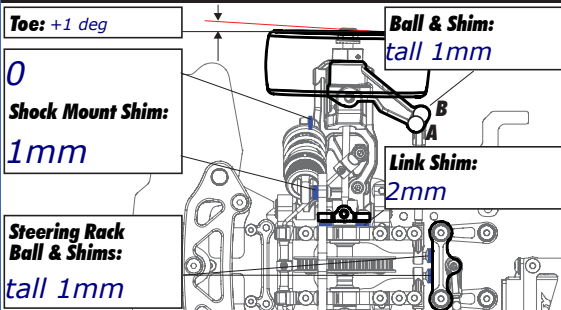
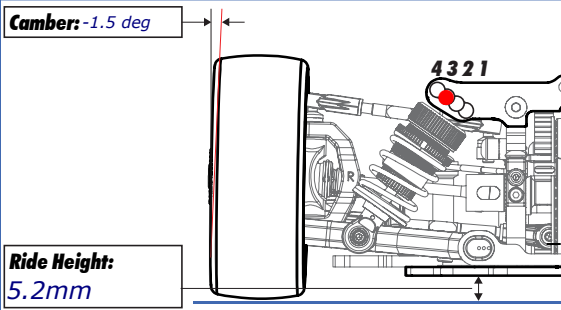

Inline Flex Mount

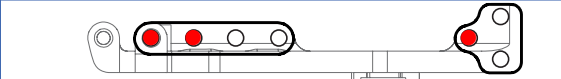

Pitch Control System

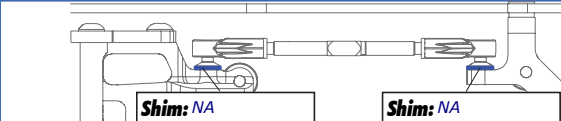

Notes

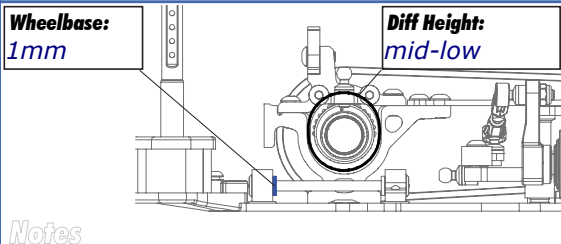

Notes

Rear

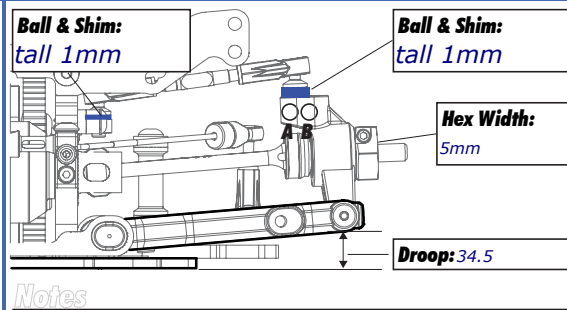
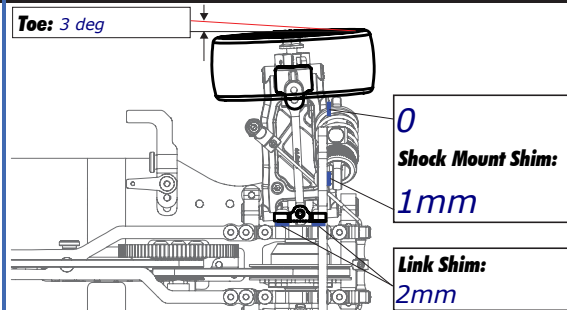
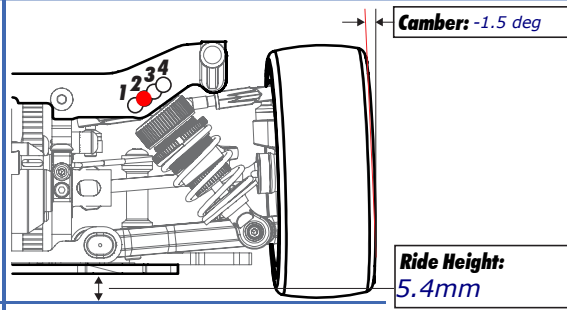

Dynamic Toe Control

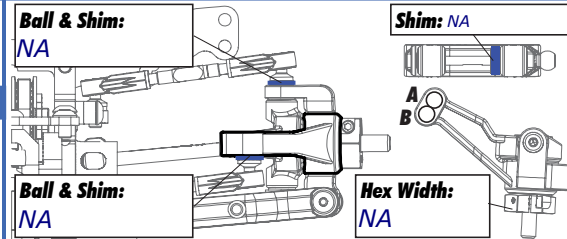

Notes

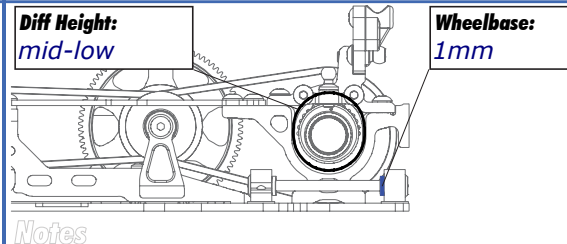

Notes

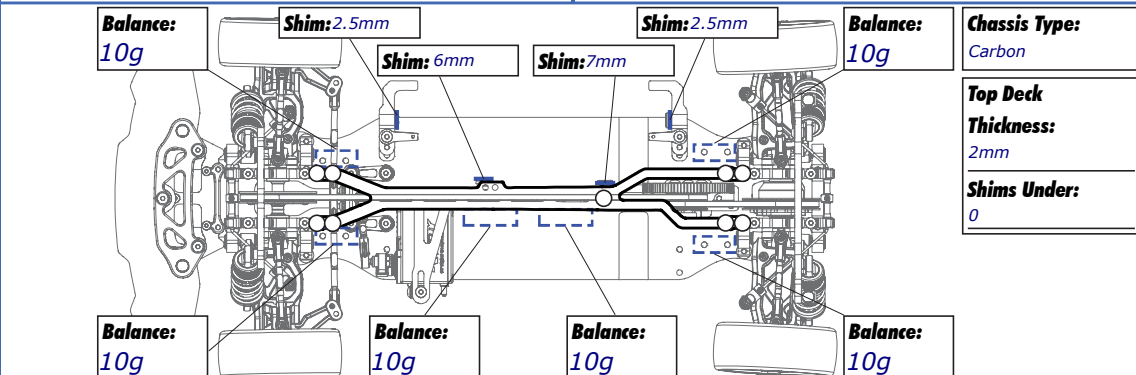

Chassis Type: Carbon
Top Deck Thickness: 2mm
Shims Under: 0

PetitRC: