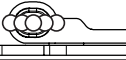
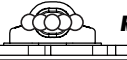
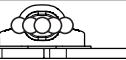
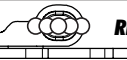

Track Info

Size: Small Medium Large XL
Surface: Carpet Asphalt
 Indoor Outdoor
Traction: Low Medium
 High Wet
Condition: Bumpy Smooth
Temperature: Ambient Track

Roll Centers

FF  **RF** 
Shim: **Shim:**
FR  **RR** 
Shim: **Shim:**

Notes

Front	Transmission	Rear
<input type="checkbox"/>	Solid Axle	<input type="checkbox"/>
<input type="checkbox"/>	Gear Diff	<input type="checkbox"/>
	Fluid	
Mass w/Fluid		

Spur: **Pinion:** **FDR:**

Notes

Front	Shocks	Rear
	Spring	
	Piston	
	Fluid	
	Rebound	
	Stroke	
	Anti-Roll Bar	

Notes

Body & Wing

Body: **Position:**
Wing: **Position:**





Notes

Electronics

Motor: **Timing:**
Battery: **Mass:**
ESC: **Settings:**
Radio: **Servo:**
Turn Circle: **STR Expo:**
Brake Expo: **THR Expo:**

Notes

Tires

Tires:
Insert: **Wheel:**
Tire Diameter (F/R):
Additive (F/R):
Additive Timing:
 Left FR  Right FR  Left RR  Right RR 

Notes

:: Team Associated

Driver: **Date:**
Track: **Event:**
Qualify: **Best Lap Time:** **Main:** **Finish:**



Front

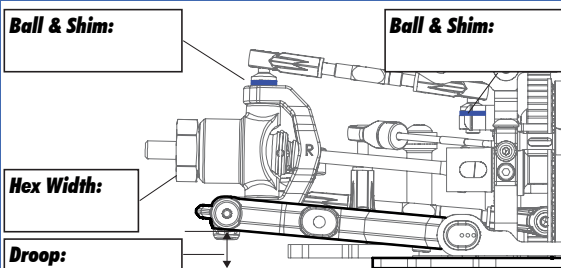
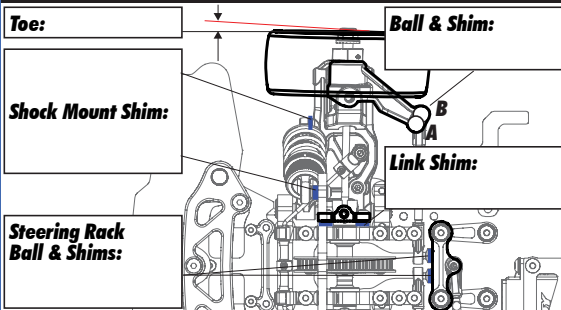
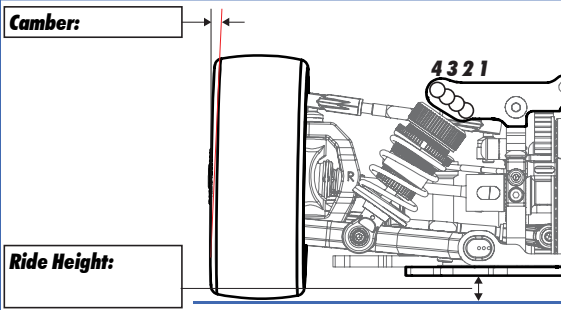

Notes

Inline Flex Mount



Pitch Control System

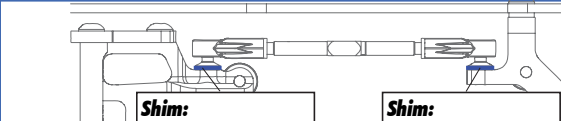

Notes

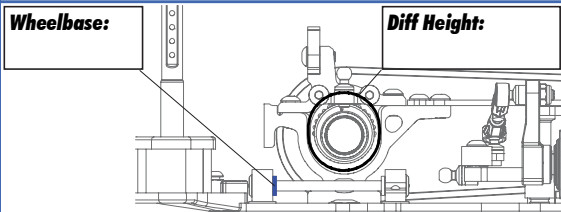

Notes

Rear

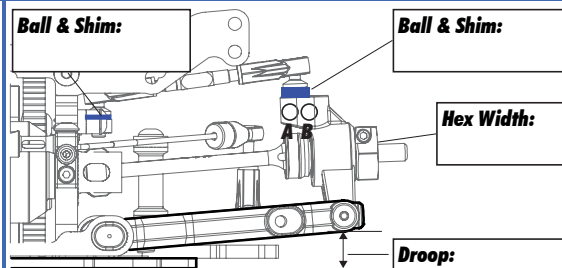
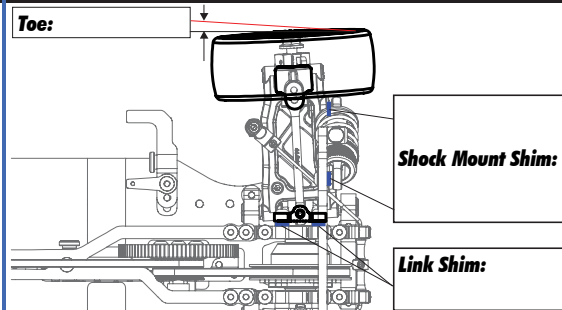
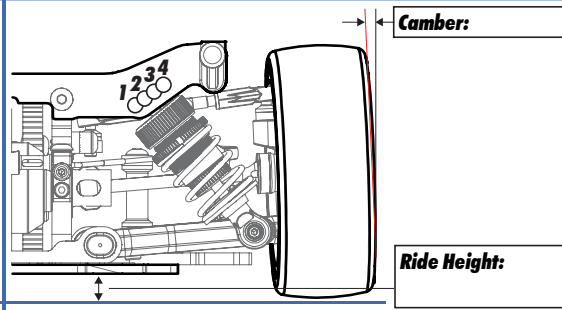

Notes

Dynamic Toe Control

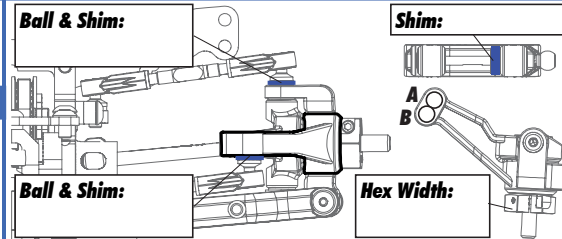

Notes

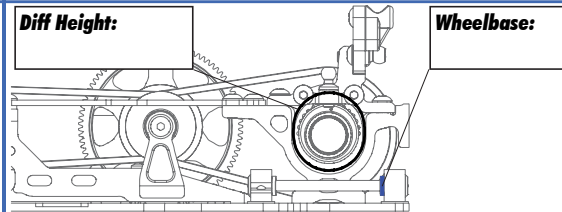

Notes

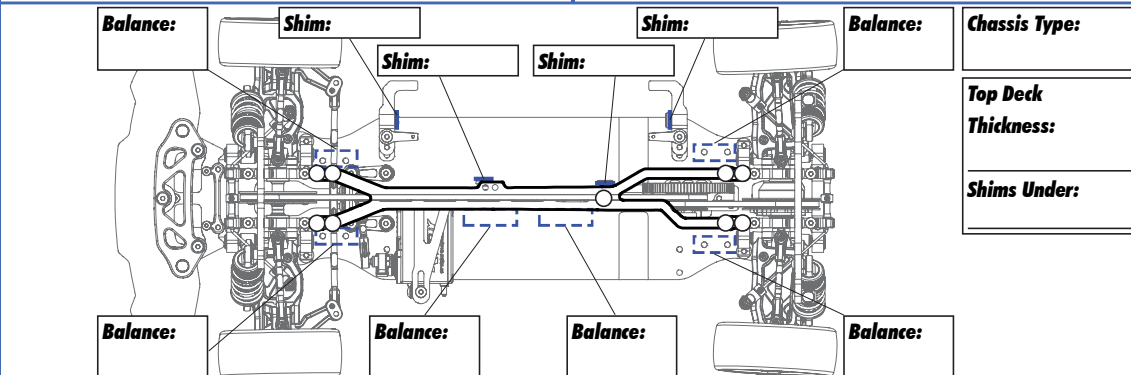

PetitRC: