

Track Info:

Size: Sm Med Lg XL

Surface: Carpet Asphalt
Indoor Outdoor

Traction: Low Medium
High Wet

Condition: Bumpy Smooth

Temperature: Ambient 72F Track

Driver: Eric Epp
Track: IIC - Westgate Las Vegas
Quality: 4 **Best Lap Time:**

Date: 11/18/18
Event: Stock TC
Main: A **Finish:** 4



Roll Centers:

FF **RF**

Shim: 0.5mm **Shim:** 1mm

FR **RR**

Shim: 1mm **Shim:** 1mm

Notes: Brass FF mount ; Single Piece FR mount

Front Transmission: Rear

Solid Axle:

Gear Diff:

Fluid: 10K

Mass w/Fluid: 2g of oil

Spur: 90 **Pinion:** 51 **FDR:** 3.52

Notes: 40mm WTF Fan on motor

Front Shocks: Rear

Xray 2.5-2.8 **Spring:** Xray 2.6

Stock **Piston:** Stock

AE 35 **Fluid:** AE 35

0 **Rebound:** 0

9.5mm **Stroke:** 9.5mm

1.4 **Anti-Roll Bar:** 1.3

Notes: Yokomo Bladders - 1mm hole in cap

Body & Wing:

Body: PF Speed6 LW **Position:** +5mm

Wing: PF Speed6 LW **Position:** Neutral

Notes: Middle section of wing cut down to 15mm

Electronics:

Motor: Handout 21.5T **Timing:**

Battery: Reedy 600 **Mass:**

ESC: Reedy 510R **Settings:** Blinky

Radio: Sanwa M12S **Servo:** PowerHD Storm7

Turn Circle: 21 **STR Expo:** -20%

Brake E.P.: 50% **THR Expo:** +40%

Notes:

Tires:

Tires: Gravity Spec Tire

Insert: **Wheel:**

Tire Diameter (F/R):

Additive (F/R): SXT 3.0

Additive Timing: 10 mins

Left FR **Right FR** **Left RR** **Right RR**

Notes: 59mm glue sidewall

Front:

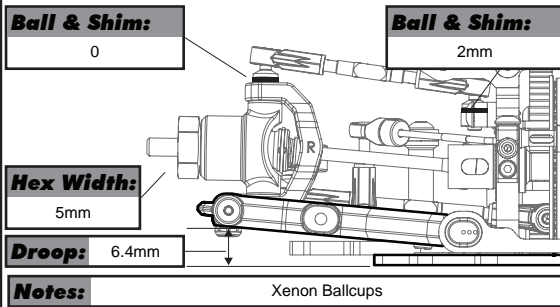
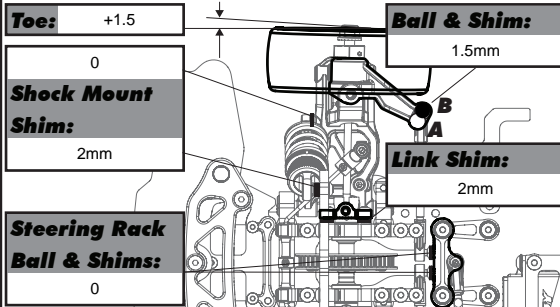
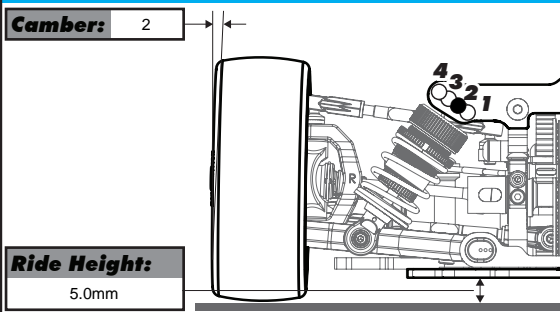

Inline Flex Mount:

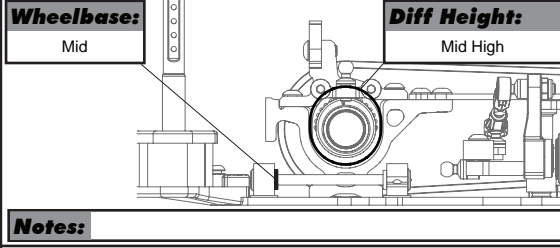
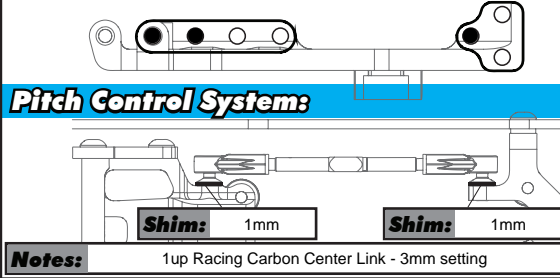

Rear:

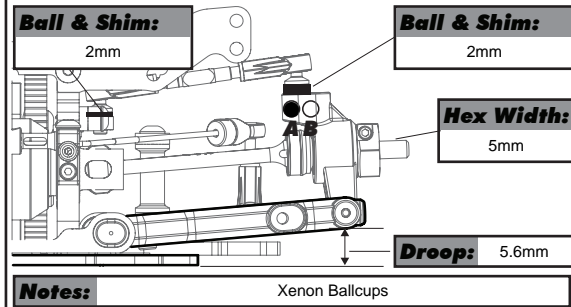
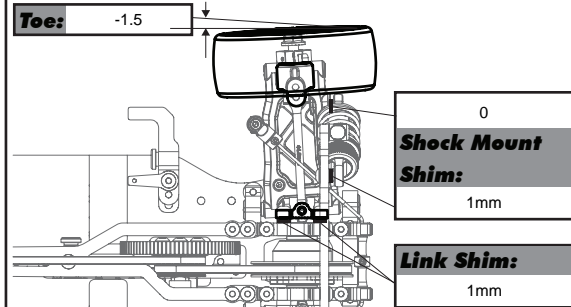
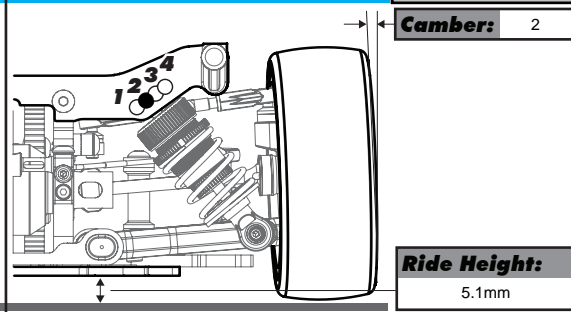

Dynamic Toe Control:

