

Track Info:

Size: Sm Med Lg XL

Surface: Carpet Asphalt
Indoor Outdoor

Traction: Low Medium
High Wet

Condition: Bumpy Smooth

Temperature: Ambient Track

Driver: Randy Caster **Date:** Dec 2018
Track: CRC Black Carpet - DTC v2 Base **Event:**
Quality: _____ **Best Lap Time:** _____ **Main:** _____ **Finish:** _____



Roll Centers:

FF **RF**

Shim: 0.7 **Shim:** 1

FR **RR**

Shim: 1 **Shim:** 1

Notes: Single Piece FR Mount

Front Transmission: Rear

Solid Axle: **Gear Diff:**

Fluid: 10K

Mass w/Fluid: 2g of oil

Spur: 114 **Pinion:** 31 **FDR:** _____

Notes: _____

Front Shocks: Rear

Yok 2.6 **Spring:** Yok 2.6

Stock **Piston:** Stock

AE 37.5 **Fluid:** AE 40

Rebound: _____

9.5 **Stroke:** 9.5

1.4 **Anti-Roll Bar:** 1.3

Notes: _____

Body & Wing:

Body: PROTOform D9 **Position:** +2mm

Wing: PF TS18 Pre-cut **Position:** Neutral

Notes: Pro-Lite Weight Body

Electronics:

Motor: Reedy M3 5.0T **Timing:** 20

Battery: Reedy 6000 LP **Mass:** _____

ESC: Reedy 510R **Settings:** _____

Radio: Sanwa M12S **Servo:** Reedy 1408

Turn Circle: 26 **STR Expo:** -5%

Brake E.P.: _____ **THR Expo:** _____

Notes: _____

Tires:

Tires: Jaco Blue / Gravity Type C / Eleix 28

Insert: _____ **Wheel:** _____

Tire Diameter (F/R): _____

Additive (F/R): SXT 3.0

Additive Timing: 5 min front - 15 min rear

Left FR **Right FR** **Left RR** **Right RR**

Notes: 58mm front sidewall glue - more if track grip increases

Front:

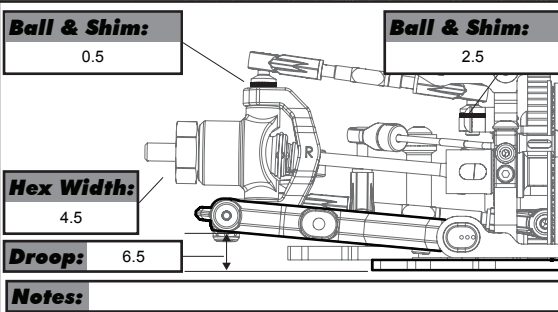
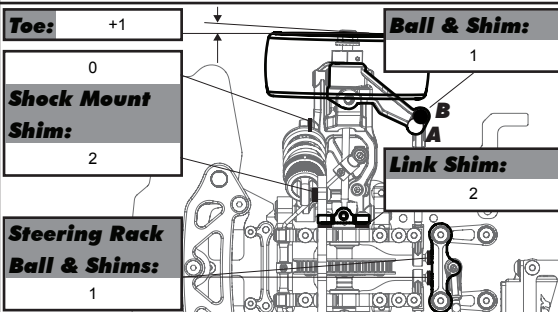
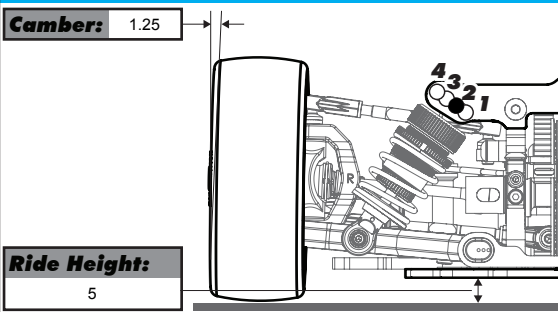

Inline Flex Mount:

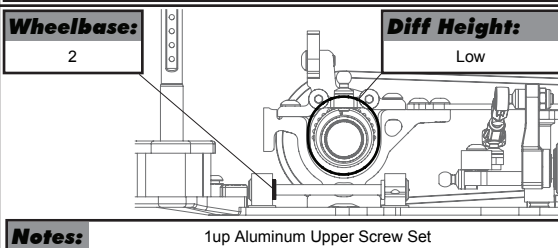
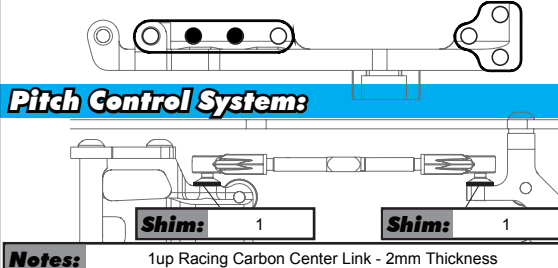

Rear:

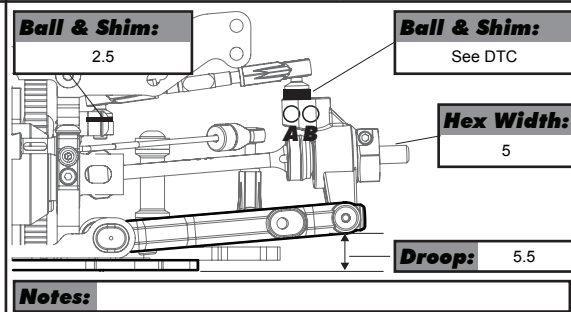
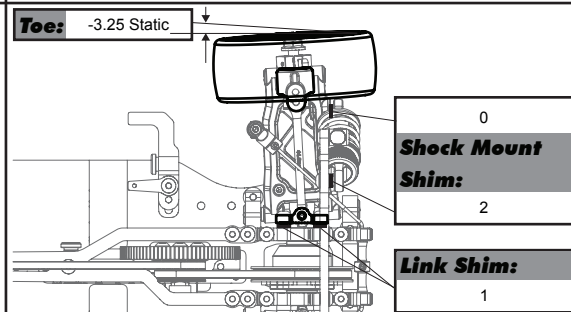
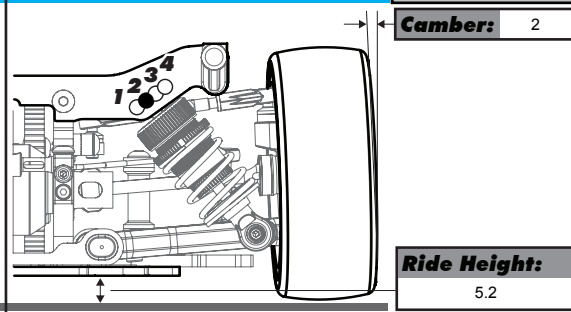

Dynamic Toe Control:

