

Track Info:

Size: Sm Med Lg XL

Surface: Carpet Asphalt
Indoor Outdoor

Traction: Low Medium
High Wet

Condition: Bumpy Smooth

Temperature: Ambient _____ Track _____

Roll Centers:

FF  RF 

Shim: _____ Shim: _____

FR  RR 

Shim: _____ Shim: _____

Notes: _____

Front Transmission: Rear

Solid Axle:

Gear Diff:

Fluid: _____

Mass w/Fluid: _____

Spur: _____ Pinion: _____ FDR: _____

Notes: _____

Front Shocks: Rear

Spring: _____

Piston: _____

Fluid: _____

Rebound: _____

Stroke: _____

Anti-Roll Bar: _____

Notes: _____

Body & Wing:

Body: _____ Position: _____

Wing: _____ Position: _____

Notes: _____

Electronics:

Motor: _____ Timing: _____

Battery: _____ Mass: _____

ESC: _____ Settings: _____

Radio: _____ Servo: _____

Turn Circle: _____ STR Expo: _____

Brake E.P.: _____ THR Expo: _____

Notes: _____

Tires:



Tires: _____

Insert: _____ Wheel: _____

Tire Diameter (F/R): _____

Additive (F/R): _____

Additive Timing: _____

Left FR  Right FR  Left RR  Right RR 

Notes: _____

Driver: _____ Date: _____
Track: _____ Event: _____
Quality: _____ Best Lap Time: _____ Main: _____ Finish: _____



Front:

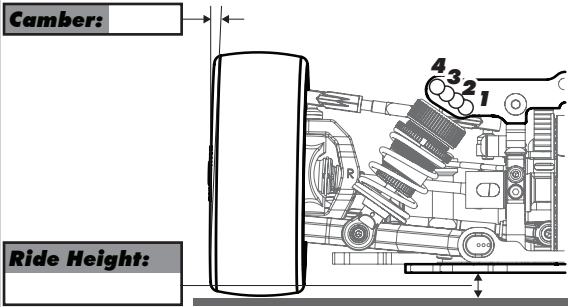

Rear:

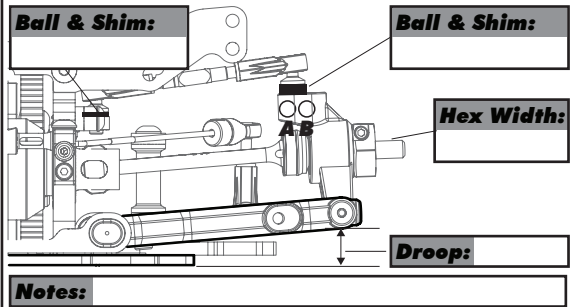
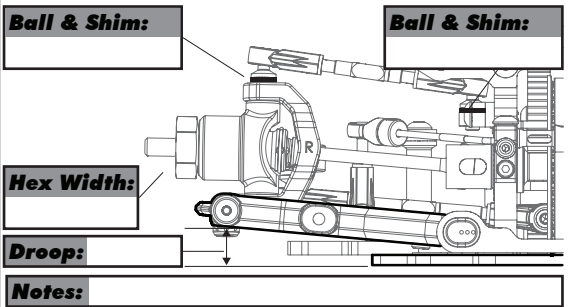
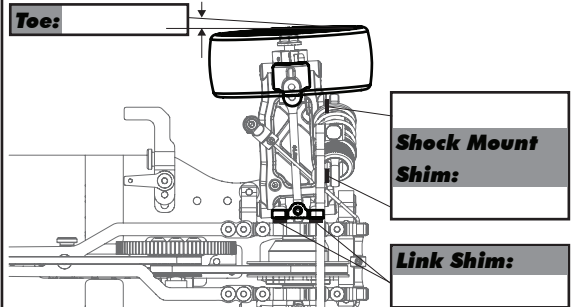
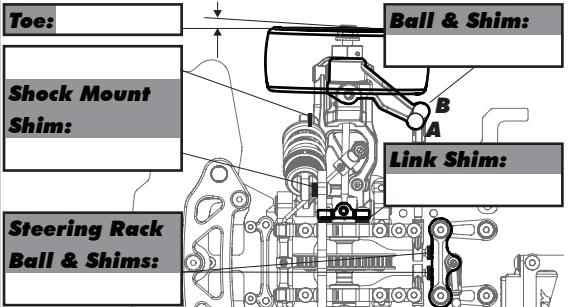
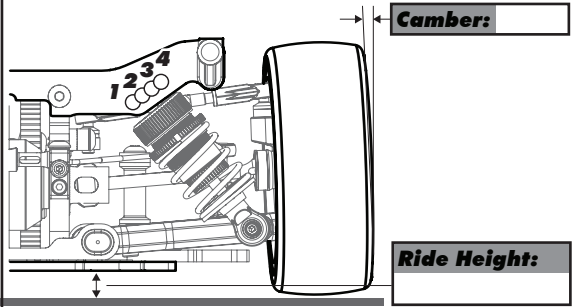

Inline Flex Mount:

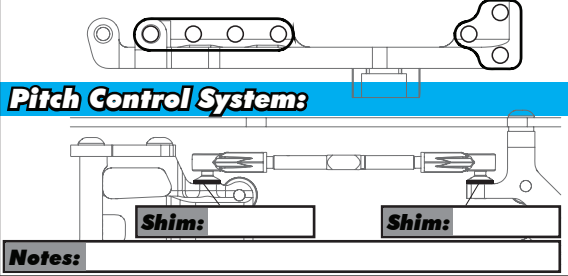

Dynamic Toe Control:

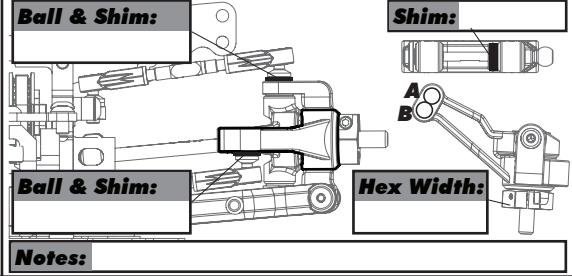

Pitch Control System:

