

Motor	Gearing
	/
Notes:	Notes:

Front	Alignment	Rear
	Ride Height	
	Camber	
	Caster	N/A
	Toe	
	Hex Width & Shims	
	Wheelbase	
	Steering Rack Ball & Shims	N/A
	Steering Block Position	N/A
	Steering Block Ball & Shims	N/A

Notes:

Suspension Geometry
Shock Position
Camber Link Position
Inner Ball & Shims
Outer Ball & Shims
Outer Arm Mount Insert
Outer Mount Shims
Inner Arm Mount Insert
Inner Mount Shims
Droop
Anti-Roll Bar

Notes:

Shocks
Fluid
Piston
Rebound
Spring

Notes:

Differentials
Type
Fluid
Diff Weight with Fluid
Cam Position
Belt Tension Number

Notes:

Tires
Type
Tire Diameter
Insert & Wheel
Additive & Amount

Notes:

Chassis
Chassis:
Top Plate:
Notes:

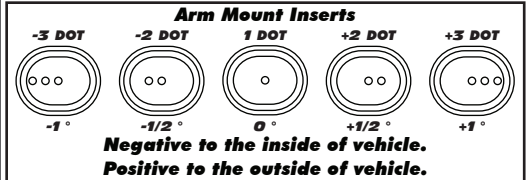
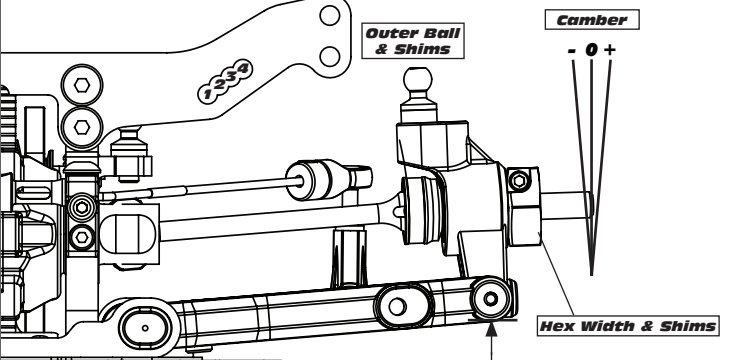
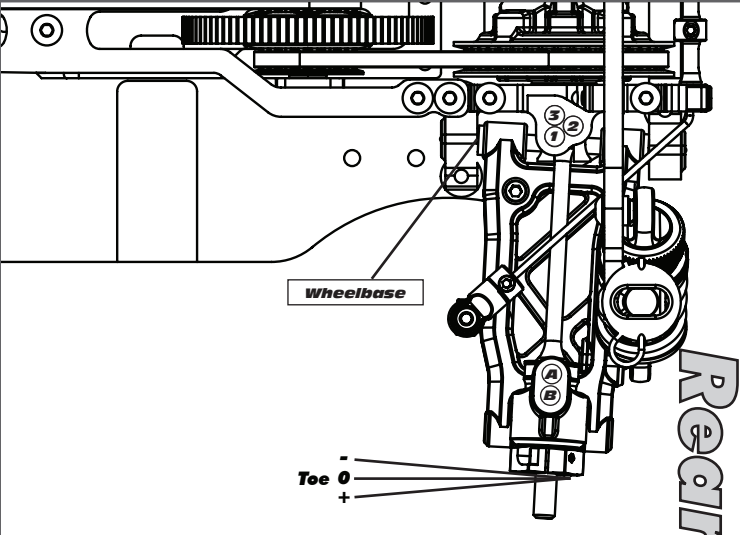

Transmitter	Speed Control
Turning Circle:	E.S.C. Type:
Steering Expo:	E.S.C. Settings:
Brake E.P. :	Software Version:
Throttle Expo:	Notes:

Battery	Body & Wing
Battery Weight:	
Battery Position:	
Notes:	Notes: