

Driver:
Track:
Conditions:

Date:
Event:

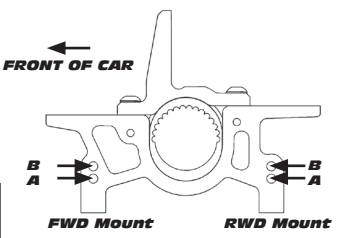
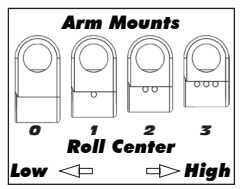
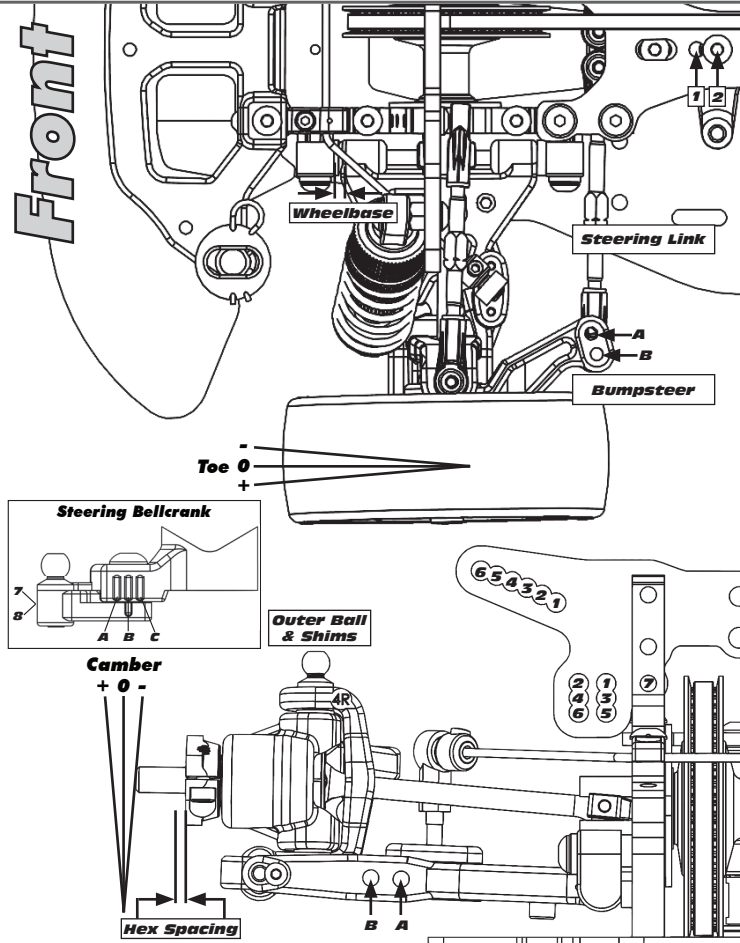

Transmitter	
Turning Circle:	
Steering Expo:	
Brake E.P.:	
Throttle Expo:	
Motor	Gearing
Notes:	Notes:

Front	Alignment	Rear
	Ride Height	
	Camber	
	Caster	N/A
N/A	Rear Hub Toe	
	Toe (Total)	
	Hex Spacing	
	Wheelbase	
	Steering Bellcrank	N/A
	Steering Link	N/A
	Bumpsteer	N/A

Notes:

Suspension Geometry	
	Shock Position
	Camber Link Position
	Outer Ball & Shims
	FWD Arm Mount
	FWD Mount Shim
	RWD Arm Mount
	RWD Mount Shims
	Drop
	Anti-Roll Bar

Notes:

Shocks	
	Oil
	Piston
	Rebound
	Spring

Notes:

Differentials	
	Type
	Setting
	Cam Holder
	Belt Tension Number

Notes:

Tires	
	Type
	Tire Diameter
	Insert & Wheel
	Additive & Amount

Notes:

Chassis	
	Chassis
	Top Plate
Notes:	Notes:

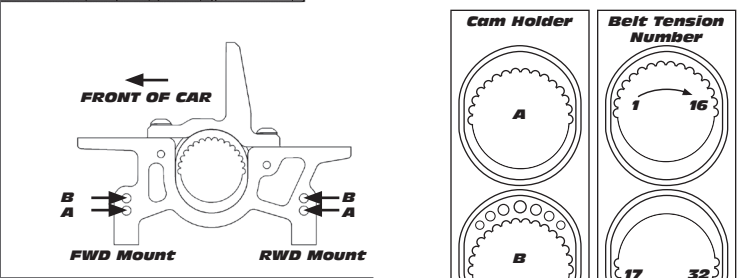
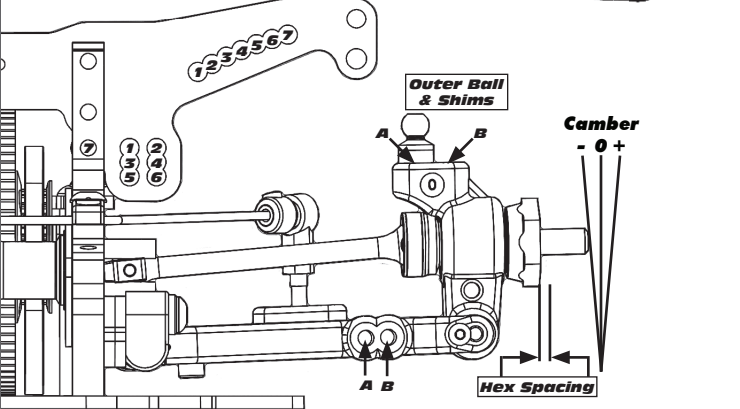
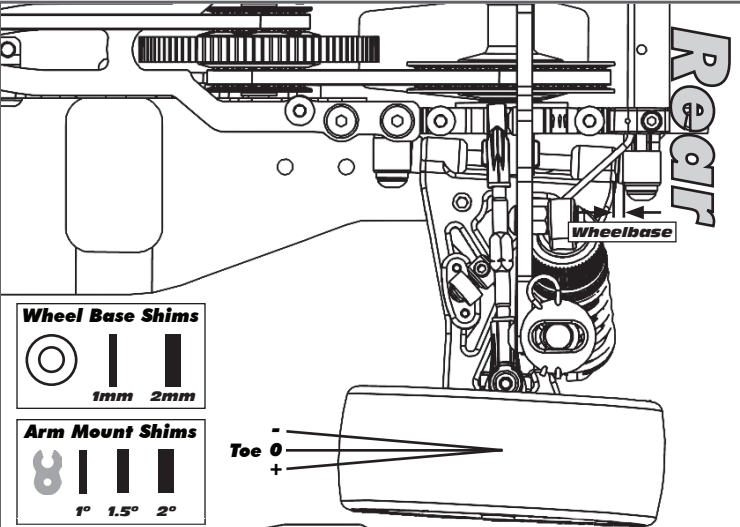

Notes:

Speed Control	
	E.S.C. Type:
	E.S.C. Settings:
Body & Wing	
Notes:	Notes:

Notes:

Battery Placement	
Notes:	Notes: