

Name: BOB STELLFLUE
Event: REEDY TOURING CAR RACE
Conditions: OUTDOOR ASPHALT, RUBBER TIRES

Date: 5/27/07
Track: TAMIYA USA

For Team Driver's setups, please visit www.RC10.com, www.TeamAssociated.com!

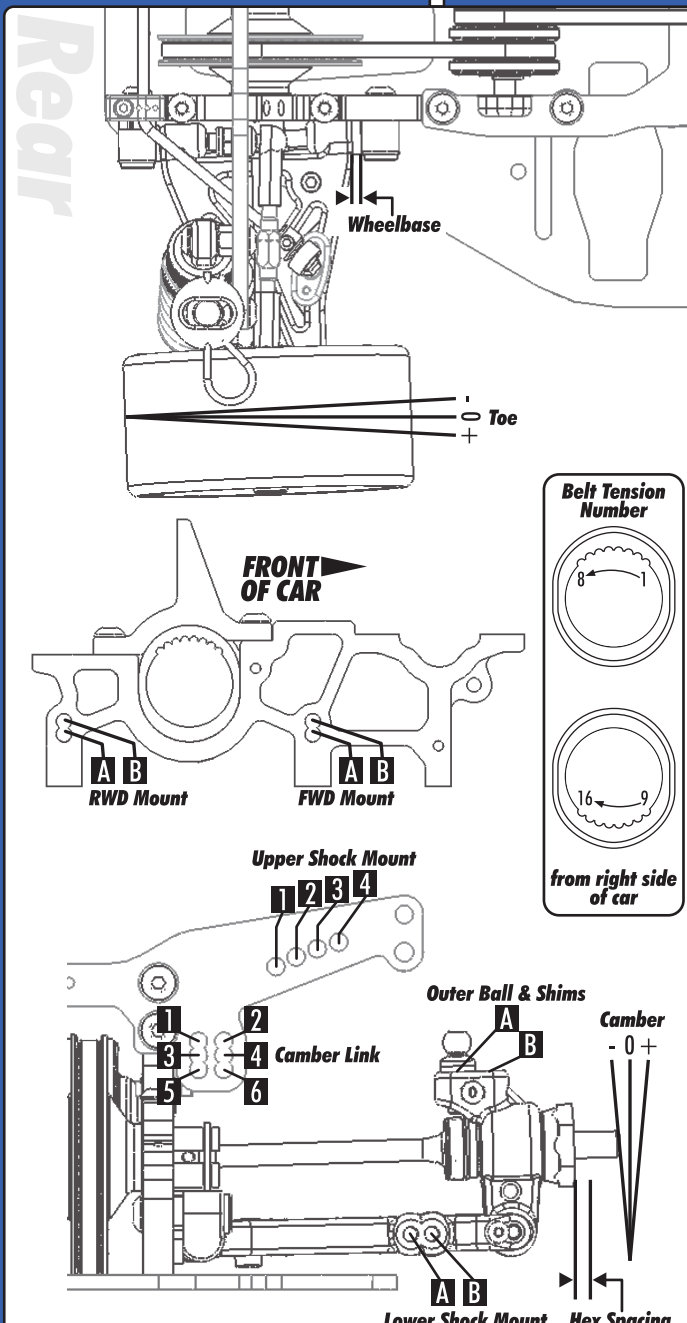

Rear	Alignment	Front
5.25mm	Ride Height	5mm
-1.5°	Camber	-1.5°
N/A	Caster	4°
-1°	Rear Hub Toe	N/A
-3° (total)	Toe	0°
.75mm	Hex Spacing	---
2mm	Wheelbase	2mm
N/A	Steering Link	1A
N/A	Bumpsteer	Black+3mm

Notes:

Diff	Type	Spool
1/8 loose	Setting	---
8	Belt Tension Number	11
A	Cam Holder	A

Notes:

RP30	Tire	RP30
---	Tire Diameter	---
---	Insert & Wheel	---
EA-Maranade	Additive & Amount	EA-Maranade

Notes:

40wt	Oil	40wt
#2	Piston	#2
---	Rebound	---
Silver	Spring	Blue

Notes:

Chassis:	ITF
Top Plate:	ITF
Notes: 4 center screws have O-Rings	

3B	Shock Position	2B
3A	Camber Link Position	3
Black+2mm	Outer Ball & Shims	Black
3A	FWD Arm Mount	2A
---	FWD Mount Shims	1°
3A	RWD Arm Mount	2A
2°	RWD Mount Shims	---
4.5	Drop	5.5
---	Anti-Roll Bar	---

Notes:

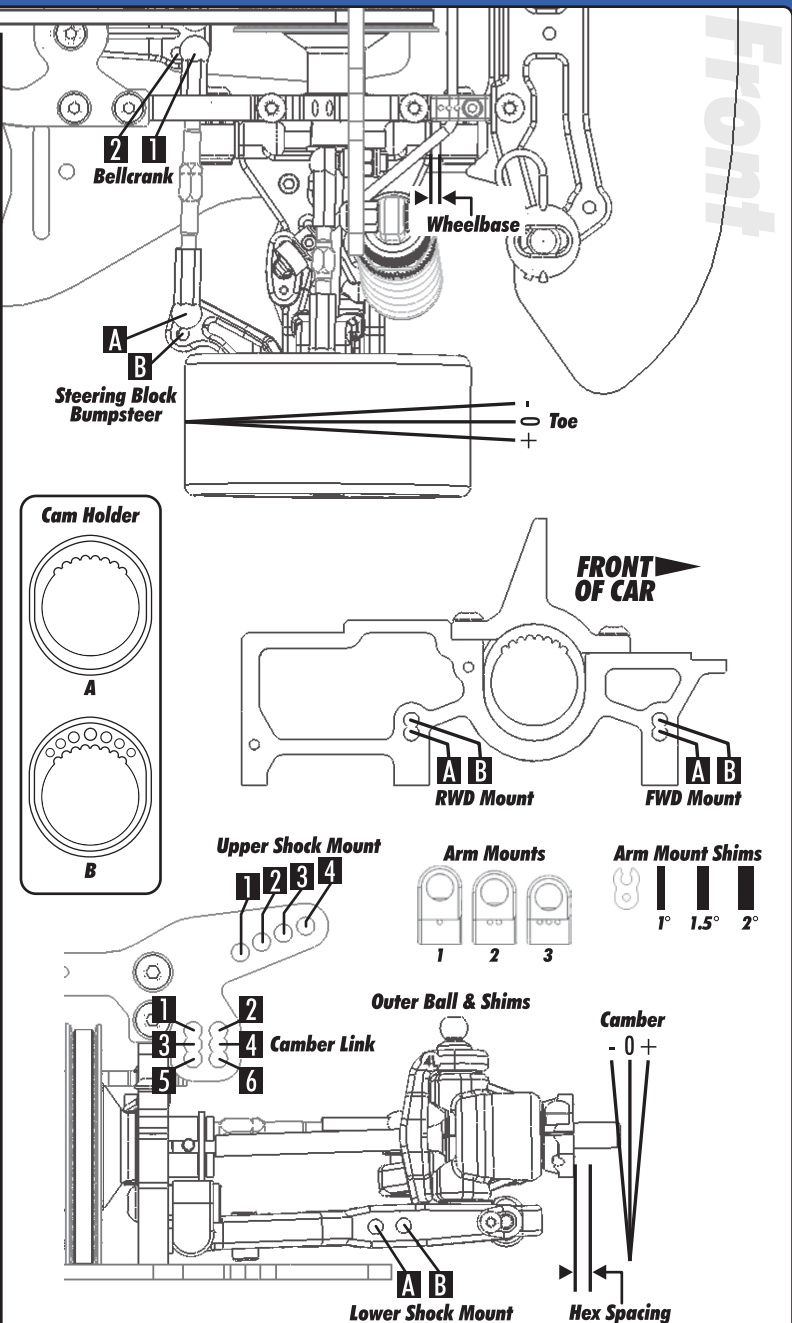

Body & Wing
 MAZDA SPEED 6, STD WING

Battery
 REEDY 6-CELL

Motor	Gear	Brush	Spring	Timing
REEDY 19T	114/41	XXX	RED / RED	0