

Name: JUHO LEVANEN
Event: LRP TOURING CAR MASTERS
Conditions: RUBBER TIRES ON CARPET

Date: 4/29/07
Track:

For Team Driver's setups, please visit www.RC10.com, www.TeamAssociated.com!

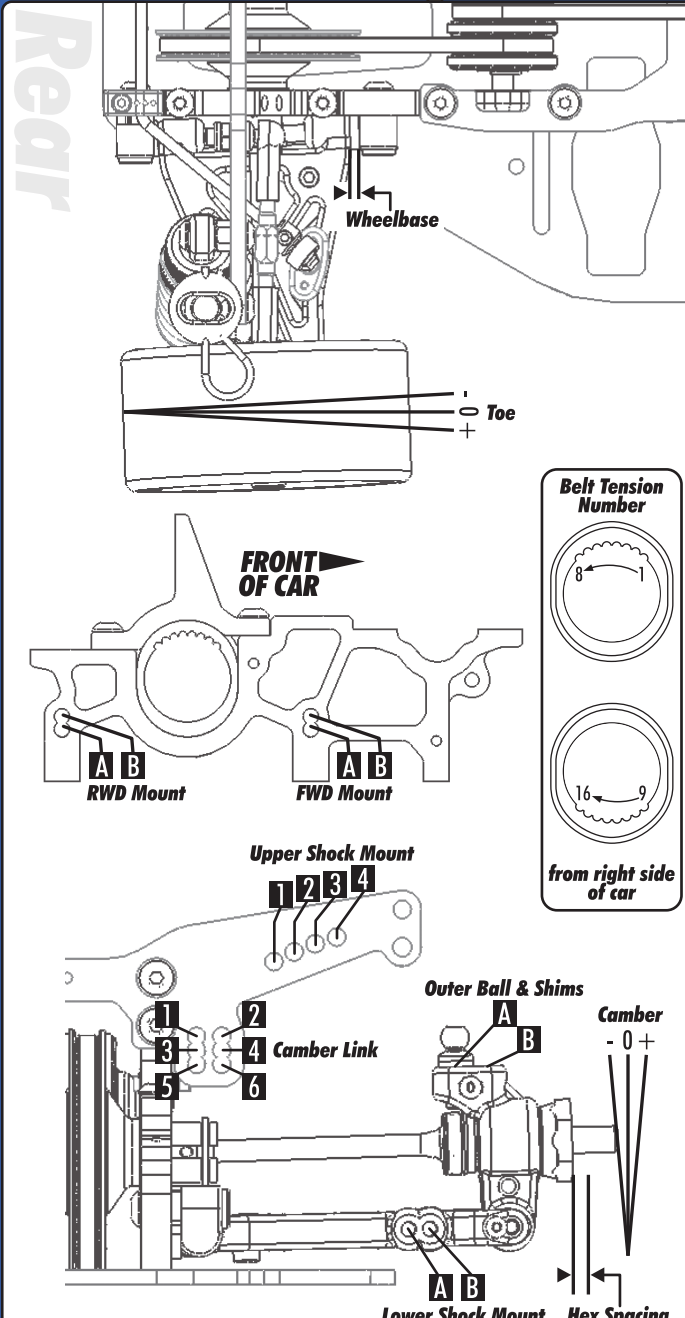

Rear	Alignment	Front
5.0mm	Ride Height	5.0mm
-2.0°	Camber	-1.5°
N/A	Caster	4°
0°	Rear Hub Toe	N/A
3.5°	Toe	-1.5°
STD	Hex Spacing	STD
2mm	Wheelbase	2mm
N/A	Steering Link	1B
N/A	Bumpsteer	0

Notes:

Differentials		
Diff	Type	One-Way
Loose	Setting	---
7	Belt Tension Number	1
A	Cam Holder	A

Notes:

Tires		
LRP 27	Tire	LRP 27
---	Tire Diameter	---
Premount	Insert & Wheel	Premount
Full	Additive & Amount	3/4

Notes: LRP for 20 minutes

Shocks		
35wt	Oil	35wt
#2	Piston	#2
25%	Rebound	25%
Silver	Spring	Blue

Notes: No rebound foam

Chassis		
Chassis:	ITF	
Top Plate:	ITF	
Notes:	O-Rings on rear top deck	

Suspension Geometry		
3B	Shock Position	2B
3A	Camber Link Position	3
A-1mm	Outer Ball & Shims	0
2A	FWD Arm Mount	1A
0	FWD Mount Shims	0
2A	RWD Arm Mount	1A
3°	RWD Mount Shims	0
2mm	Droop	1mm
1.25	Anti-Roll Bar	1.50

Notes: Droop measured above R.H.

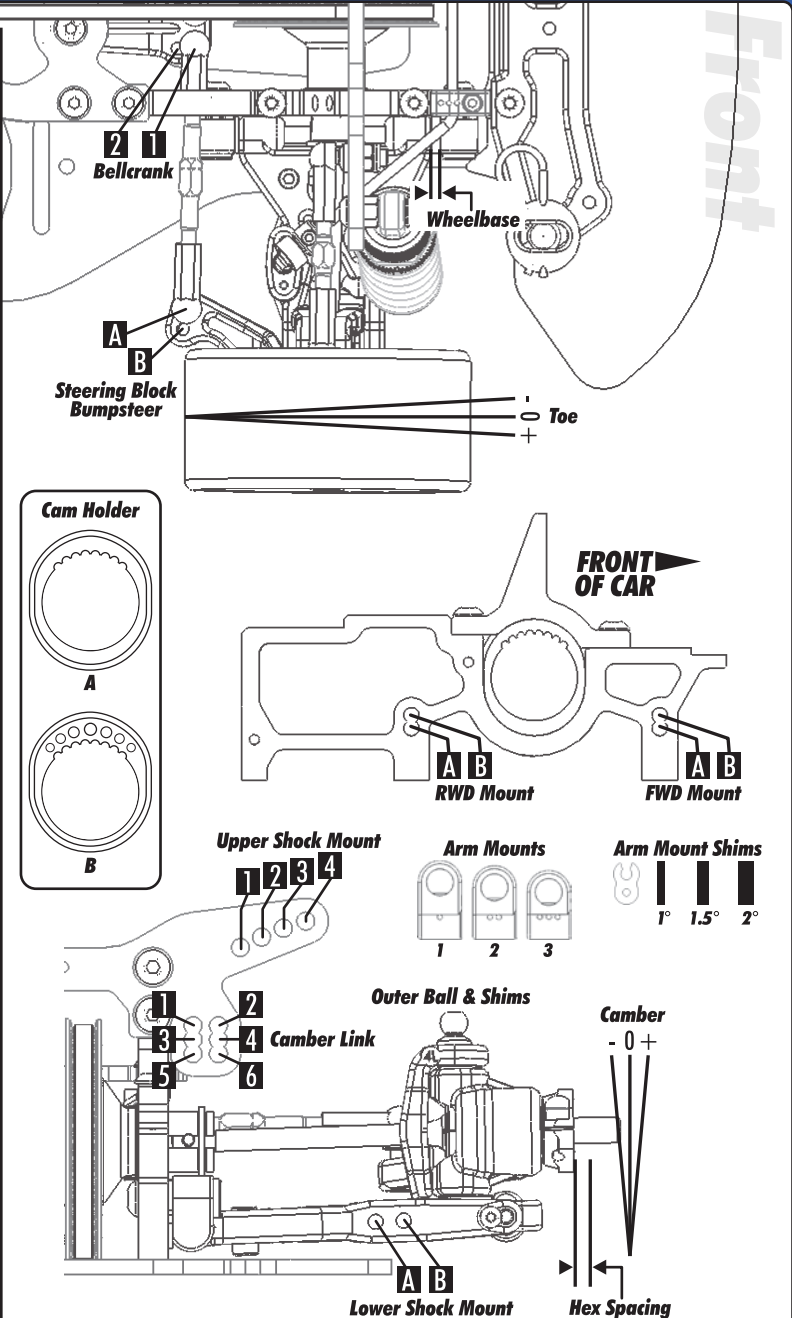

Body & Wing
MAZDA 6 L.W.

Battery
REEDY 5-CELL FWD

Motor LRP X11 3.5T
Gear 18/93
Brush
Spring
Timing