

TC5 FACTORY Team Setup Data

Name: _____ Date: _____
 Event: _____ Track: _____
 Conditions: **FOAM TIRE KIT SETTINGS**

For Team Driver's setups, please visit www.RC10.com or www.TeamAssociated.com!

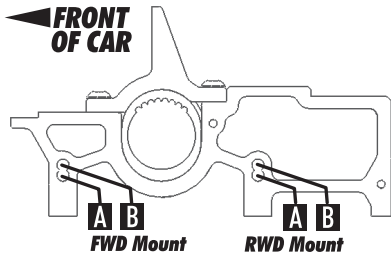
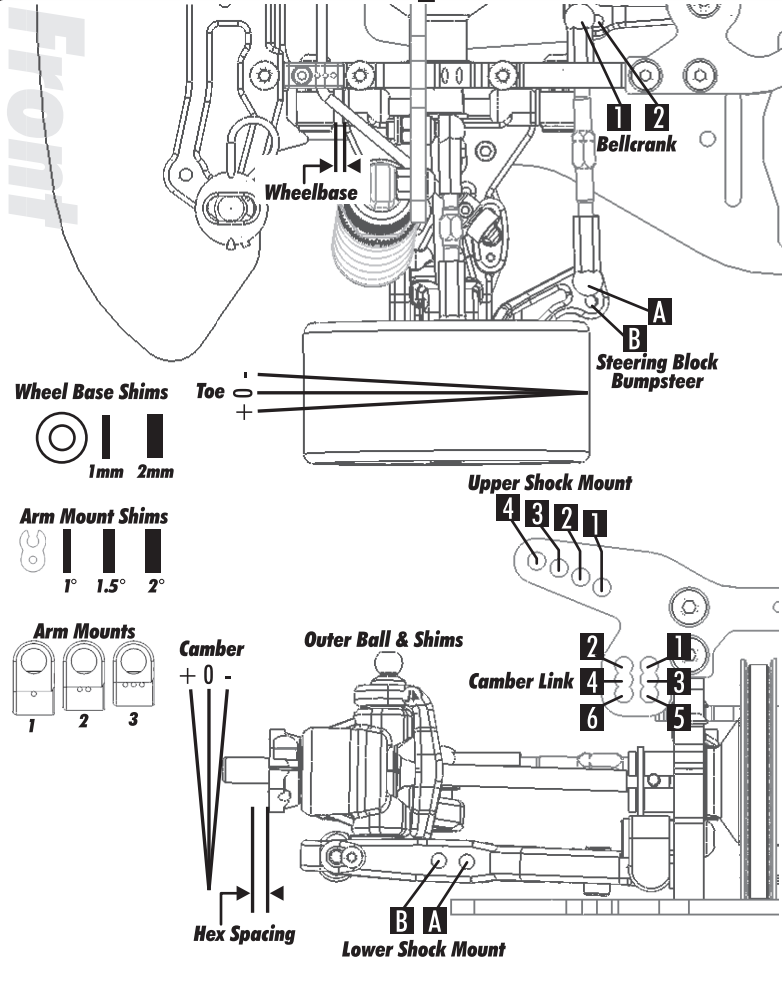

Front	Alignment	Rear
4.5mm	Ride Height	4.5mm
- 2.0 deg	Camber	- 2.5 deg
6 deg	Caster	N/A
+ 0.5 deg	Rear Hub Toe	- 1 deg
-	Toe (Total)	- 3 deg
1mm	Hex Spacing	-
1 A	Wheelbase	2mm
Black + 4mm	Steering Link	N/A
	Bumpsteer	N/A

Notes:

Suspension Geometry		
2 B	Shock Position	2 B
4	Camber Link Position	5 A
Black + 0	Outer Ball & Shims	Black + 2mm
2 A	FWD Arm Mount	3 A
2 deg	FWD Mount Shims	1.5 deg
2 A	RWD Arm Mount	3 A
2 deg	RWD Mount Shims	3.5 deg
6	Droop	5
-	Anti-Roll Bar	-

Notes:

Shocks		
50 wt	Oil	30 wt
# 3	Piston	# 3
No Rebound	Rebound	No Rebound
Purple	Spring	Blue

Notes:

Differentials		
Alum. Diff	Type	Alum. Diff
1/8 loose	Setting	1/8 - 1/4 loose
A	Cam Holder	B
4	Belt Tension Number	14

Notes:

Tires		
-	Tire	-
57.5mm	Tire Diameter	57.5mm
-	Insert & Wheel	-
Inside 1/3	Additive & Amount	Full

Notes:

Chassis

Chassis: Std.
 Top Plate: Std.
 Notes:

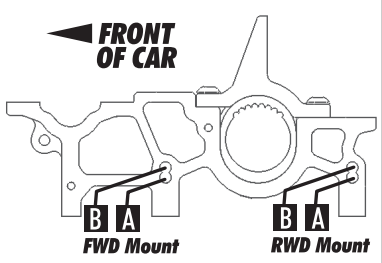
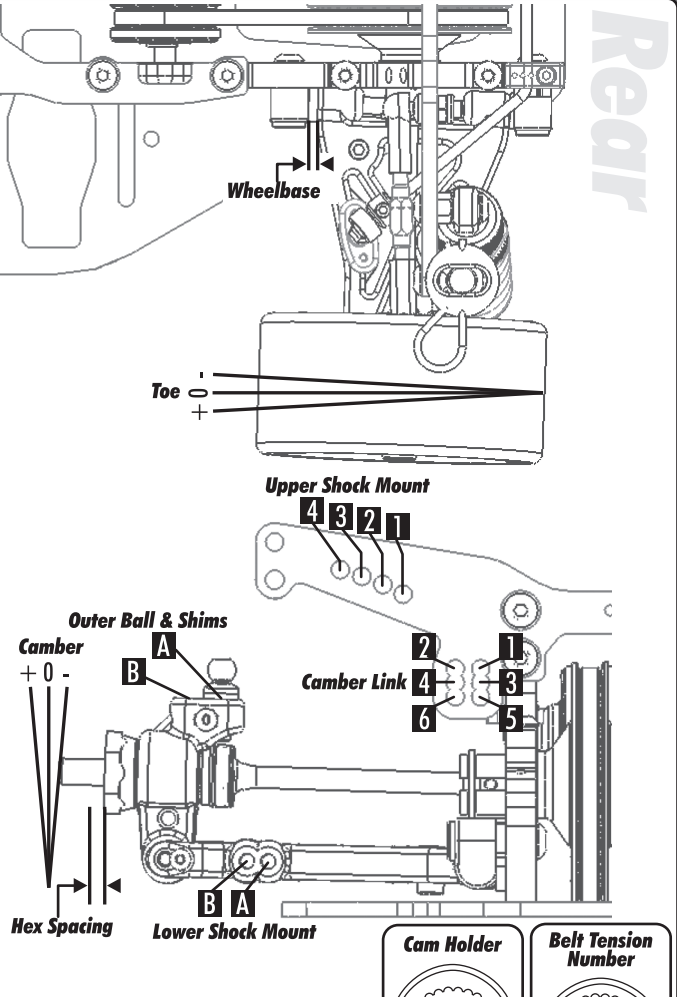

Transmitter	
Turning Circle:	3.5 ft
Steering Expo:	-
Brake E.P. :	-
Throttle Expo:	-
Speed Control	
S.C. Type:	-
S.C. Settings:	-

Motor	Gear	Notes
-	- / -	

Body & Wing
 -

Battery
 -