

TC28 TEAM KIT

1:28 Scale 4WD Electric
On Road Competition Kit



TEAM ASSOCIATED



1:28 Scale 4WD Electric On Road Competition Kit Manual

#20169 TC28 4WD KIT



CHAMPIONS *by* DESIGN

AssociatedElectrics.com

TEAM ASSOCIATED

⚡ Introduction

Thank you for purchasing this Team Associated product. This assembly manual contains instructions and tips for building and maintaining your new vehicle. Please take a moment to read through the manual and familiarize yourself with the steps. We are continually changing and improving our designs; therefore, actual parts may appear slightly different than the illustrations. New parts will be noted on supplementary sheets located in the appropriate parts bags.

Check each bag for these sheets before you start to build.

Check www.rc10.com for the latest versions of our instruction manuals.

⚡ TC28 Features

- Steel chassis plate for low center of gravity
- Independent suspension front and rear
- Mid-motor configuration with equal length belts (front and rear)
- Fluid filled gear differentials front and rear with height and belt tension adjustment
- Anti-roll bar system for front and rear suspension
- Silicone grease lubricated shocks
- Constant velocity driveshafts
- RadBody Mako X2 included
- Compatible with all Reedy Electronics for 28th scale
- White wheels included that fit optional front wheel flanges to tune steering feel
- Universal front bumper included

⚡ Additional

Your new TC28 Kit comes unassembled and requires the following items for completion (refer to AssociatedElectrics.com for suggestions):

- R/C two channel surface frequency radio system
- AA-size batteries for transmitter
- Electronic Speed Control ("ESC")
- Steering servo
- R/C electric motor
- Battery charger (a peak detection charger, or LiPo compatible charger)
- 2 cell LiPo battery pack
- Polycarbonate specific spray paint
- Cyanoacrylate glue ("CA") (#1697)
- Thread locking compound (#1596)
- Pinion gear, size determined by type/turn or kV of motor

⚡ Other Helpful Items

- Silicone Shock Fluid (Refer to AssociatedElectrics.com for complete listings)
- 4.5mm Nut Wrench
- FT Body Scissors (#1737)
- Calipers or a Precision Ruler
- .050", 0.9mm, 1.3mm, 1.5mm Hex Wrenches
- FT Body Reamer (#1499)
- Soldering Iron
- FT 28th Scale Camber Tool (#21481)
- Small Needle Nose Pliers
- Hobby Knife



Associated Electrics, Inc.
21062 Bake Parkway.
Lake Forest, CA 92630



Customer Service
Tel: 949.544.7500
Fax: 949.544.7501

:: Hardware - 1:1 Scale View





Button Head (bhcs)

	2x4mm (21666)
	2x5mm (21666)
	2x6mm (21673)
	2x12mm (21463)









Flat Head (fhcs)

	2x4mm (21667)
	2x5mm (21667)
	2x6mm (21667)

Ball Bearing / Axle Spacer

	2 x 4 x 1.2mm (21468)
	2 x 5 x 2mm (21468)
	4 x 7 x 2mm (21468)
	5 x 8 x 2mm (21468)





Shims and Washers

	2.2x4x0.5mm (21480)
	3.8x2x0.5mm (21649)
	3.8x2x1mm (21650)
	3.8x2x1.75mm (21480)
	3.8x2x2.50mm (21480)
	5x3x0.2mm (21644)
	5.5x0.5mm (31381)
	5.5x1.0mm (31382)
	5.5x2.0mm (31383)

Phillips Head (phcs)

	1 x 3mm (21669)
	1 x 8mm (21669)

Set Screws

	2x2mm (21681)
	2x3mm (21668)
	2x4mm (21683)
	2x6mm (21668)
	3x3mm (25225)

Nuts (lock/plain)

	M2 LockNut, Aluminum (21689)
---	------------------------------

:: Notes

Table of Contents

1..... Cover	11..... Top Plates / Turnbuckles Build Bag 6
2..... Introduction	13..... Shocks Build Bag 7
3..... 1:1 Hardware “Fold Out” / Tuning Tips	13..... Battery Mount / Bumper Build Bag 8
4..... Table of Contents	15..... Wheels and Tires Build Bag “Wheel”
5..... Chassis Build Bag 1	15..... Body / Wing Build
6..... Bulkheads / Diffs Build Bag 2	16..... Back Cover
8..... Steering Rack / Servo Build Bag 3	
9..... Steering Blocks / Hubs Build Bag 4	
10..... Upper Susp. Arms / Roll Bars Build Bag 5	

Notes



This symbol indicates a special note or instruction in the manual.



This symbol indicates the number of the same part that is required.



This symbol indicates the order within a step to assemble parts.



This symbol indicates there are optional FT parts available



This symbol indicates a Racers Tip.



This symbol indicates where Thread Lock Adhesive should be applied. *not included

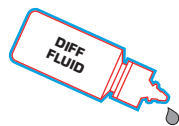

This symbol indicates where Diff Fluid should be applied.

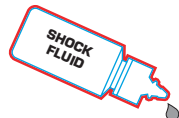

This symbol indicates where Shock Fluid should be applied.



This symbol indicates where FT Silicone Grease should be applied. *not included



This symbol indicates where FT Diff Lube should be applied. *not included



This symbol indicates where Black Grease should be applied.



This symbol indicates where Green Slime can be applied. *not included



There is a 1:1 hardware foldout page in the front of the manual. To check the size of a part, line up your hardware with the correct drawing until you find the exact size. Each part in the foldout has a number assigned to it for ordering replacement parts.

Bag 1 - Step 1

FRONT

21646 Ballstud 3.5mm 2x4mm

21458 TC28 Suspension Arm, Lower

21480 x2 2.2x4x0.5mm Lower Pivot Ball Shim

21457 TC28 Chassis

21764 Ballstud 3.5mm 2x2mm

21647 x2 Threaded Pivot Ball 3.5mm

Note: Use small pliers to lightly hold pivot balls to assemble. Use caution not to mar the surface of the pivot ball.

21667 x2 2x4mm FHCS

Build Rear Left and Right

Bag 1 - Step 2

REAR

21458 TC28 Suspension Arm, Lower

21646 Ballstud 3.5mm 2x4mm

21480 x2 2.2x4x0.5mm Lower Pivot Ball Shim

21647 x2 Threaded Pivot Ball 3.5mm

21764 Ballstud 3.5mm 2x2mm

Note: Use small pliers to lightly hold pivot balls to assemble. Use caution not to mar the surface of the pivot ball.

21667 x2 2x4mm FHCS

Build Rear Left and Right

Bag 1 - Step 3

21683 x4 2x4mm Set Screw

FRONT: 0.5mm
REAR: 1mm

Bag 2 - Step 1

FRONT

21483 TC28 Bulkhead, Right

21483 TC28 Bulkhead, Left

21667 x4 2x4mm FHCS

REAR

21764 x2 Ballstud 3.5mm 2x2mm

21483 TC28 Bulkhead, Right

21483 TC28 Bulkhead, Left

21667 x4 2x4mm FHCS

Bag 2 - Step 2

21485 3x5x0.2mm Diff Shim

21484 TC28 Diff Case

21485 3x0.5mm O-Ring

21485 TC28 Outdrive

21485 3x5x0.2mm Diff Shim

21484 TC28 Diff Cap

21485 3x0.5mm O-Ring

21485 TC28 Outdrive

21484 TC28 Diff Pin

21485 TC28 Sun Gear

21484 TC28 Diff Pin

21485 TC28 Sun Gear

Build Front and Rear

Bag 2 - Step 3

21485 x4 1.3x3x0.1mm Diff Shim

21485 x4 Planet Gear

21485 Diff Cross Pin

21667 x4 2x4mm FHCS

21484 TC28 Diff Case Ring

21485 TC28 Diff Case Gasket

BLACK GREASE #6588

DIFF FLUID

FRONT DIFF: 30k
REAR DIFF: 10k

Build Front and Rear

Bag 2 - Step 4

FRONT

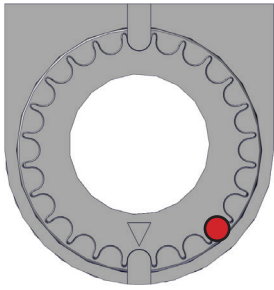

CAM POSITION:

Always use the same cam position on both sides of the car.



Line up key feature with highlighted slot. Arrow should face away from the center of the car.
Use these cams to tighten or loosen the belt tension.

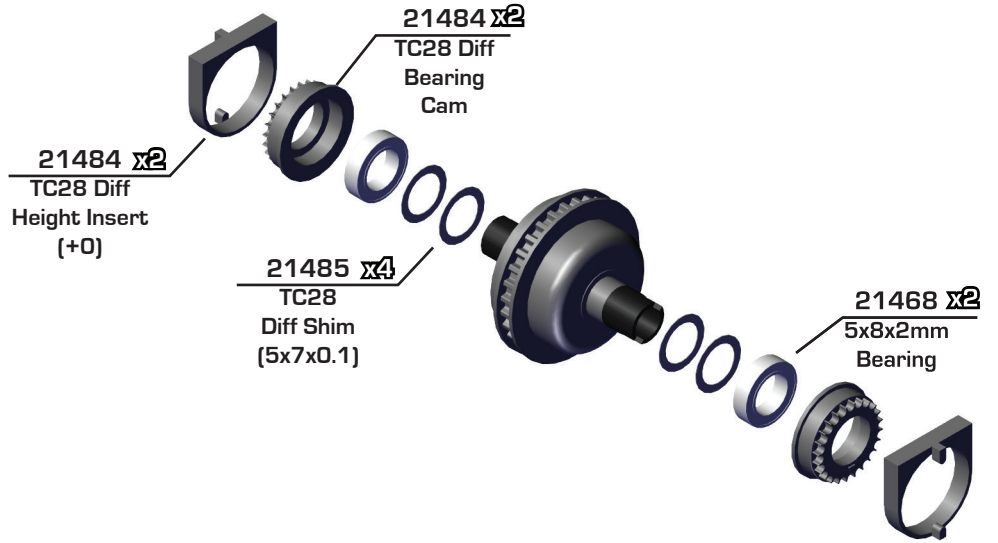

Bag 2 - Step 5

REAR

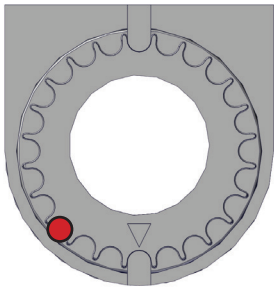

CAM POSITION:

Always use the same cam position on both sides of the car.



Line up key feature with highlighted slot. Arrow should face away from the center of the car.
Use these cams to tighten or loosen the belt tension.



Bag 2 - Step 6

21482 TC28 Motor Mount

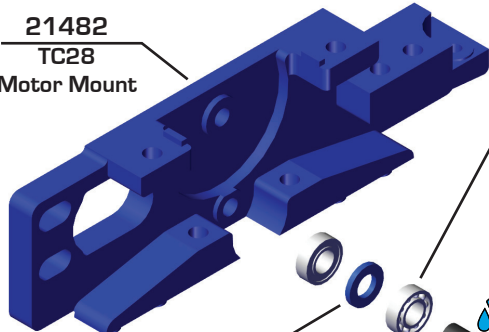

21650 3.8x2mm Washer

21468 x2 2x4x1.2mm Bearing



21673 2x6mm BHCS

Note: Do not overtighten the 2x6mm BHCS

21689 M2 Locknut

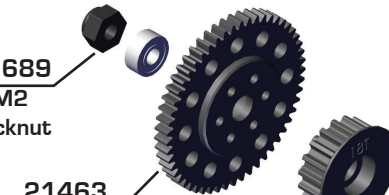

21463 TC28 Spur Gear, 53T

21463 TC28 Pulley Gear, 18T

21468 x2 2x5x2mm Bearing

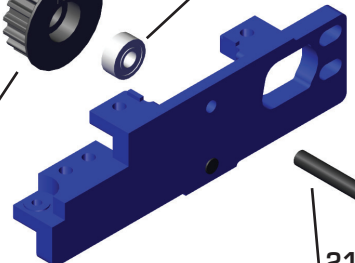

21463 2x12mm BHCS

Bag 2 - Step 7

21472 x2
TC28
Belt Set

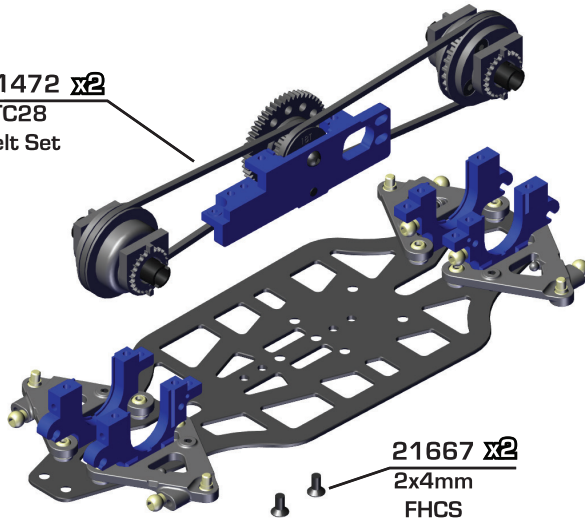

21667 x2
2x4mm
FHCS

21666 x2
2x4mm
BHCS

21476
Servo
Mount
Plate

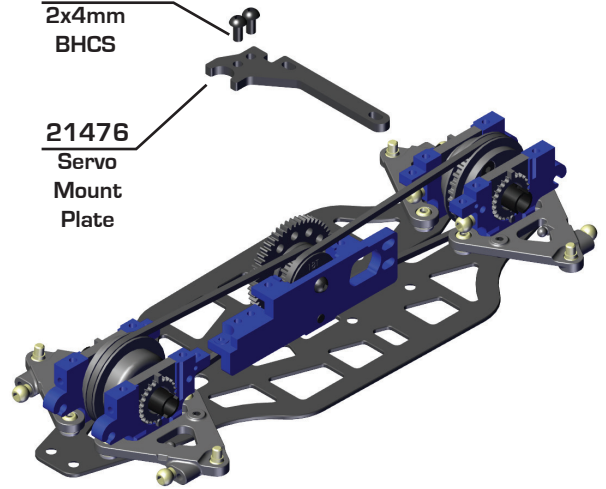

Bag 3 - Step 1



Note:
Take note of the
orientation of the
Steering Bellcrank
when installing.

21764 x3
Ballstud
3.5mm
2x2mm

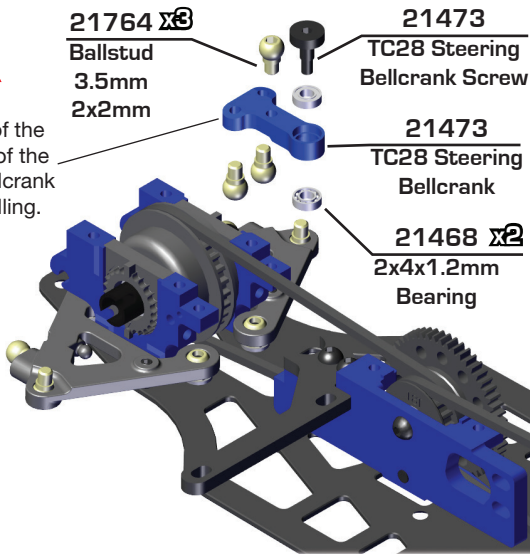

21473
TC28 Steering
Bellcrank Screw

21473
TC28 Steering
Bellcrank

21468 x2
2x4x1.2mm
Bearing

OPTIONAL
27175
Reedy Micro
Hi-Speed
Servo

21633 x2
Servo Mount

Servo
*Not Included
(20T Spline)

21666 x2
2x4mm
BHCS

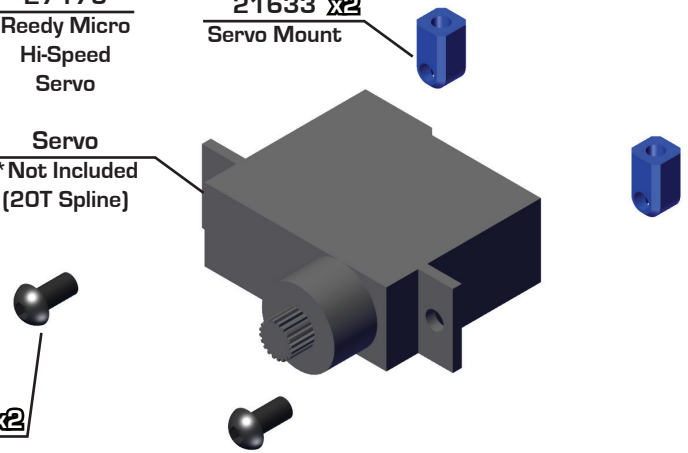

Bag 3 - Step 2

21668
2x6mm
Set Screw

21647
Threaded
Pivot Ball
3.5mm

21633
Servo Horn

21666 x3
2x4mm
BHCS

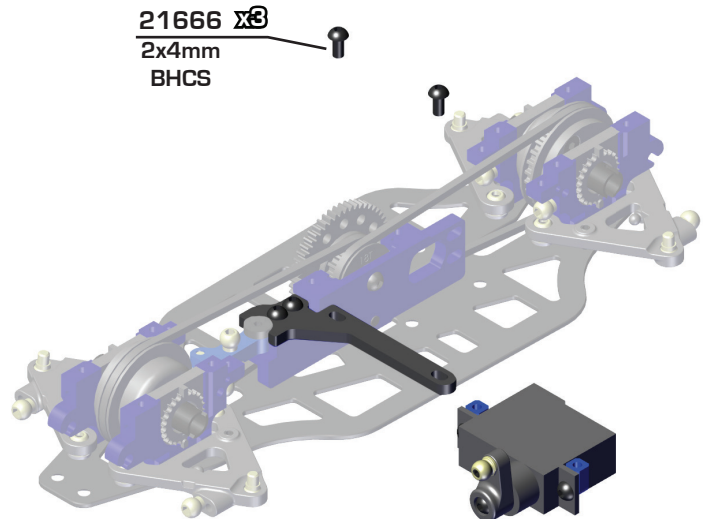

Bag 3 - Step 3

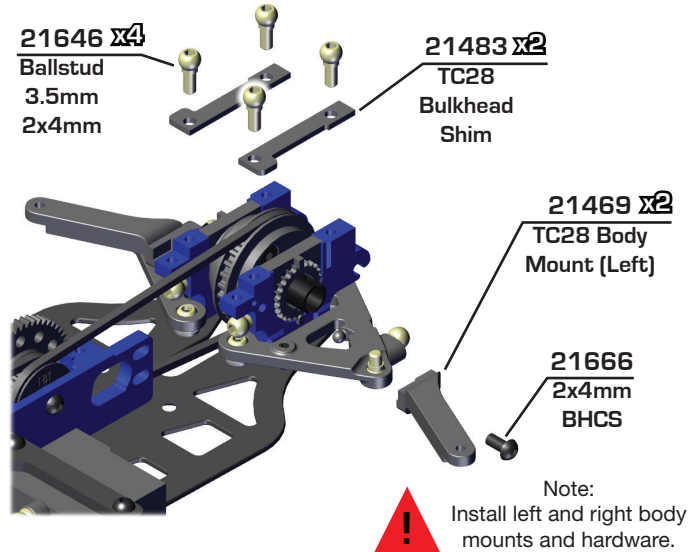
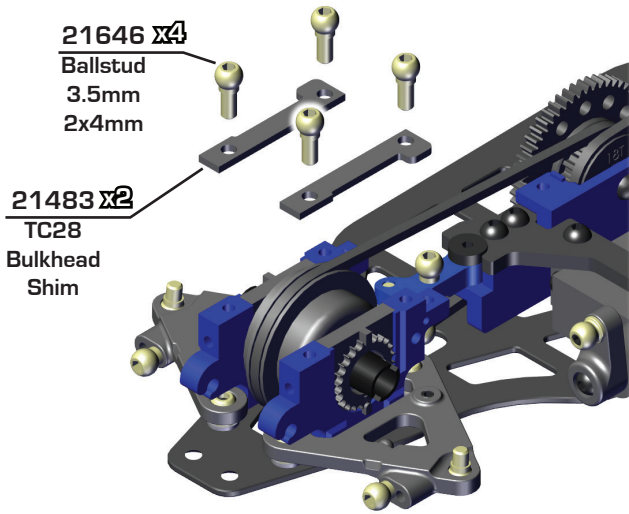

Bag 4 - Step 1

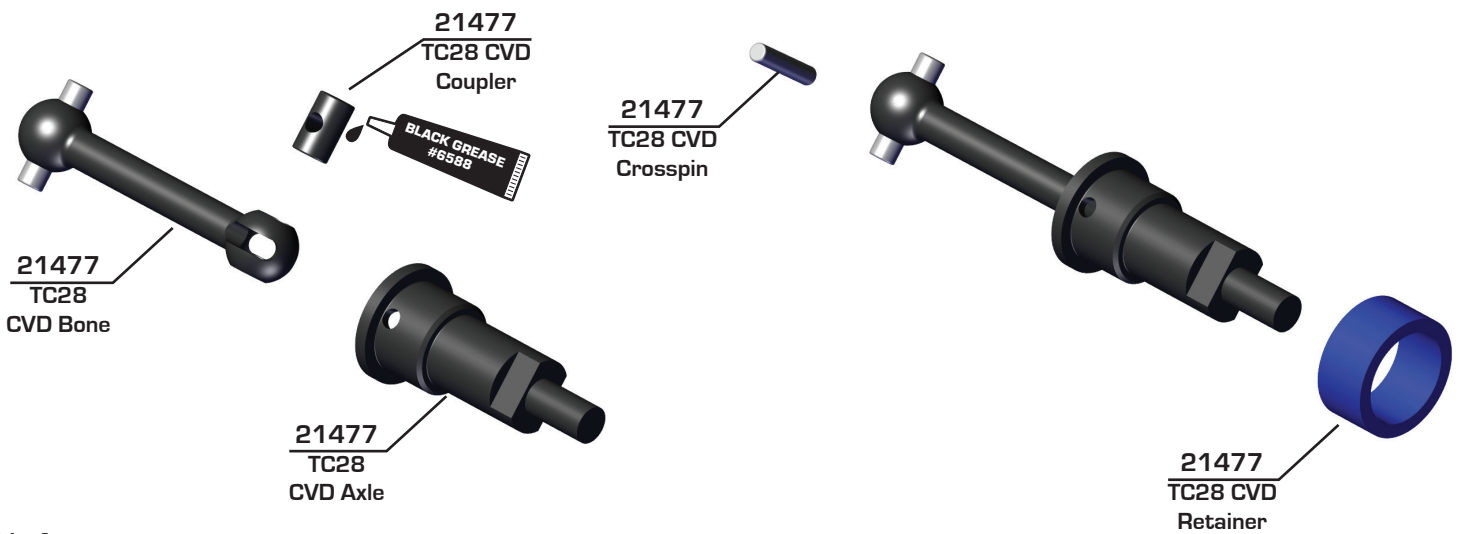

Build x4

Bag 4 - Step 2

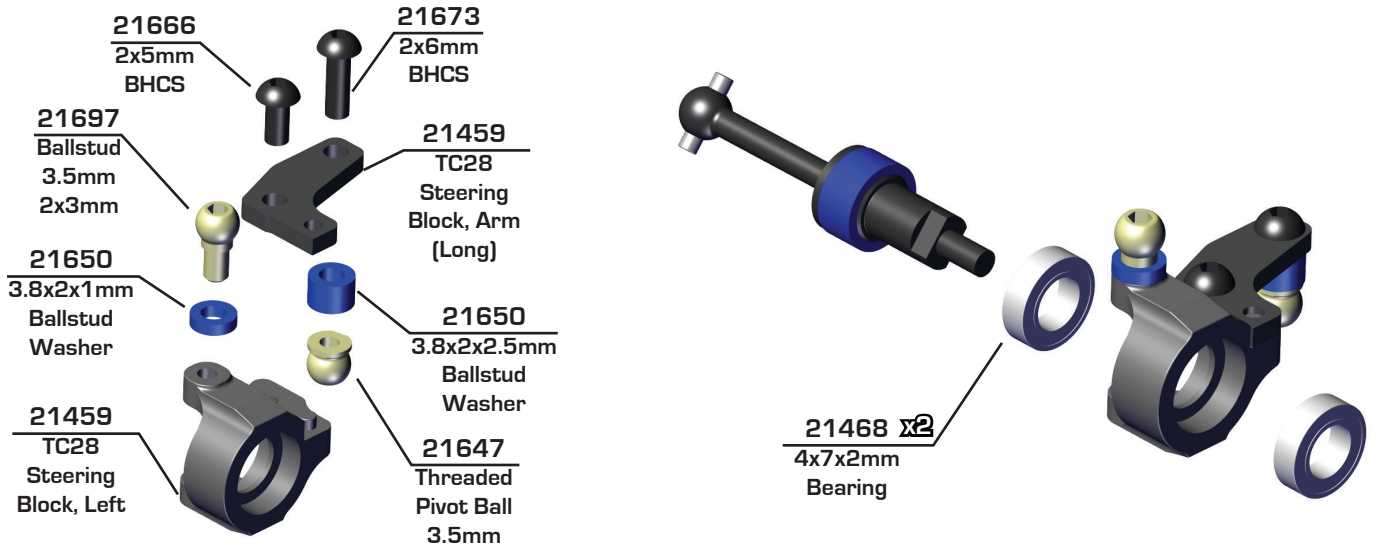

Build x2 Front, Left and Right Side

Bag 4 - Step 3

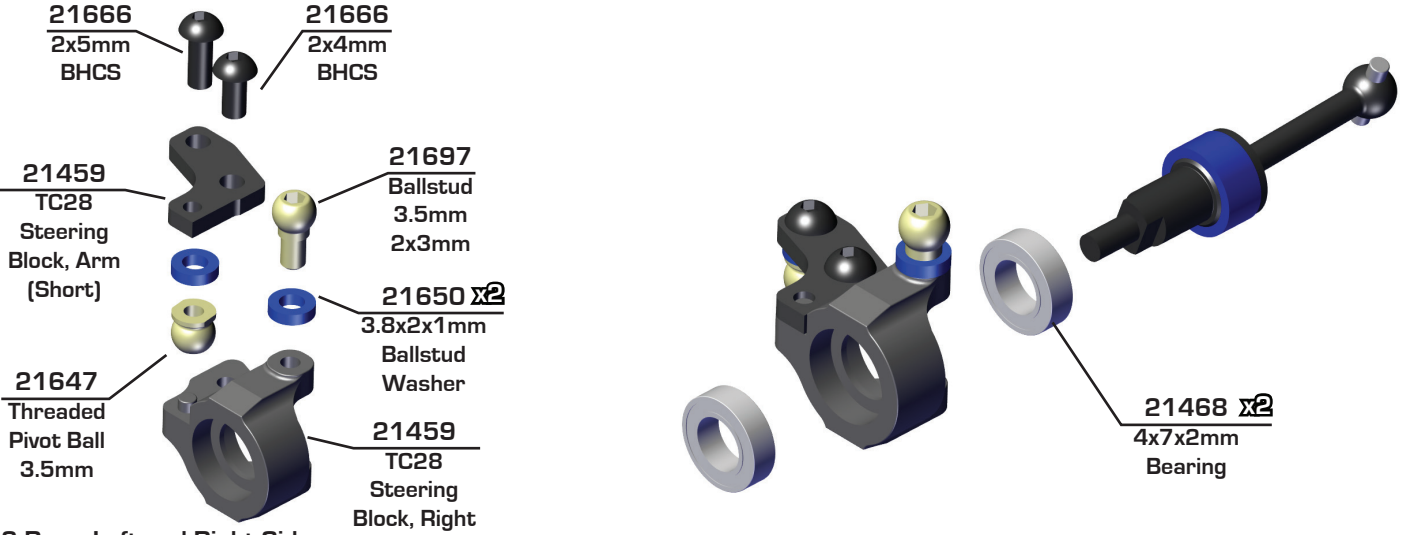

Build x2 Rear, Left and Right Side

Bag 4 - Step 4

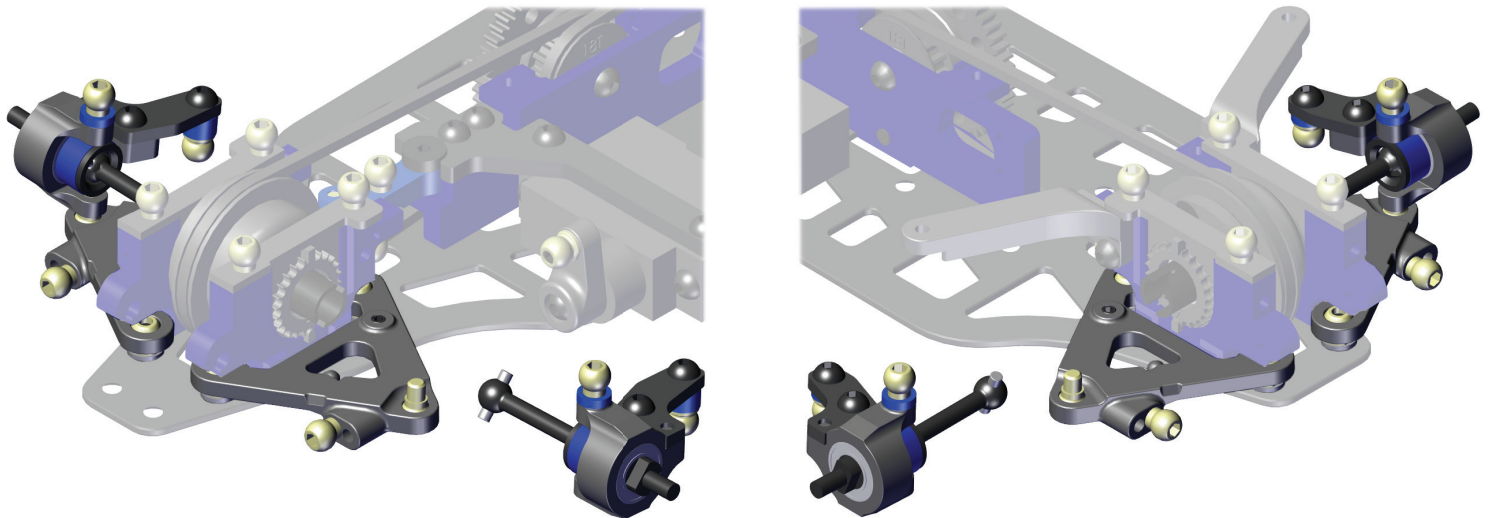

Build Left and Right Side

Build Left and Right Side

Bag 5 - Step 1

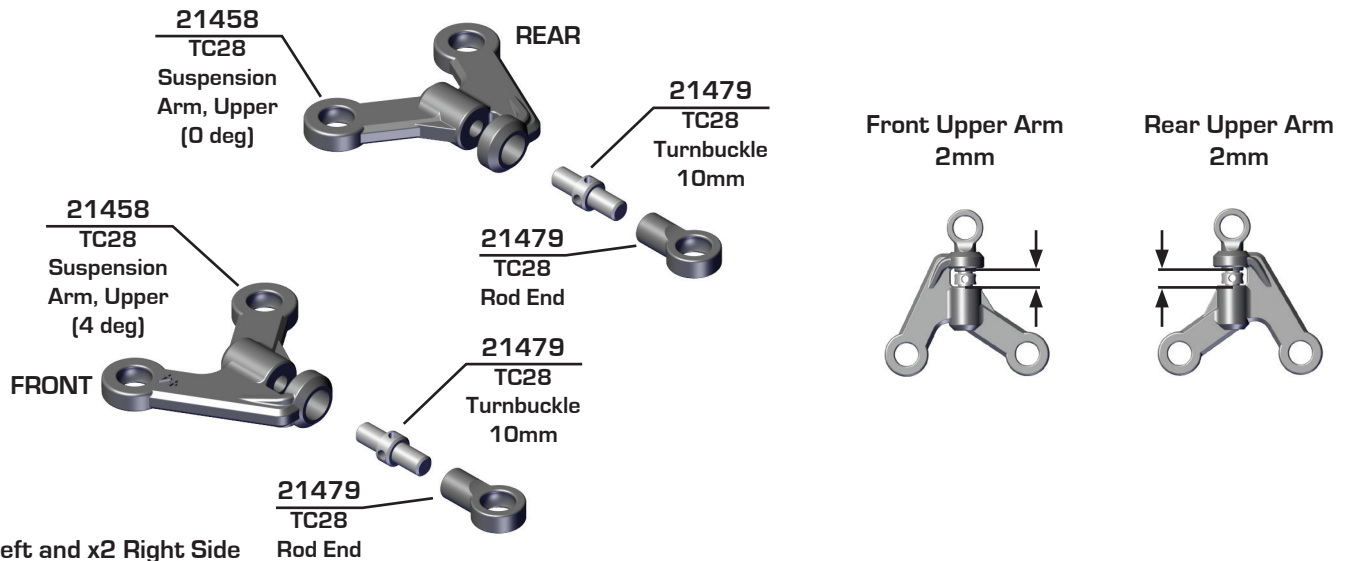

Build x2 Left and x2 Right Side

:: Bag 5 - Step 2

21471 x2
TC28
Anti-Roll
Bar Ball

21471 x2
TC28 Anti-
Roll Bar
Pivot Collar

21470
TC28 Anti-Roll
Bar Set
(Front - 0.8mm)
(Rear - 0.8mm)

21681 x4
2x2mm
Set Screw

Note:
Set end of roll bar flush
with Anti-Roll Bar Ball.

Build Left and Right Side

:: Bag 5 - Step 3

21471 x2
TC28
Anti-Roll
Bar Link

21471 x2
TC28
Anti-Roll
Bar Link

Note:
Set end of roll bar flush
with Anti-Roll Bar Ball.

:: Bag 6 - Step 1

21479 x2
TC28
Rod End

21479
TC28
Turnbuckle
14mm

Note:
Notch indicates left hand
thread. Install notch on left
side of car.

Note:
Pinch ballcups on pivot ball
with pliers lightly if tight.

8.2mm

Build Left and Right Side

Bag 6 - Step 2

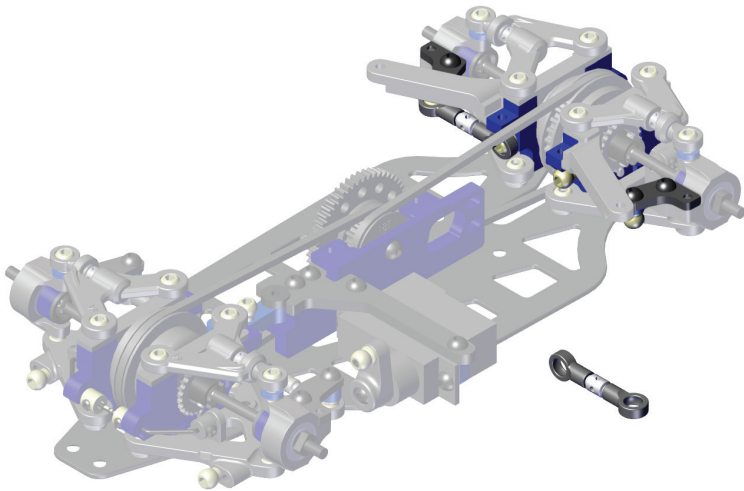

Build Left and Right Side

21479 x2
 TC28
 Rod End

21479
 TC28
 Turnbuckle
 14mm

Note:
 Notch indicates left hand thread. Install notch on left side of car.

Note:
 Pinch ballcups on pivot ball with pliers lightly if tight.

4mm

Bag 6 - Step 3

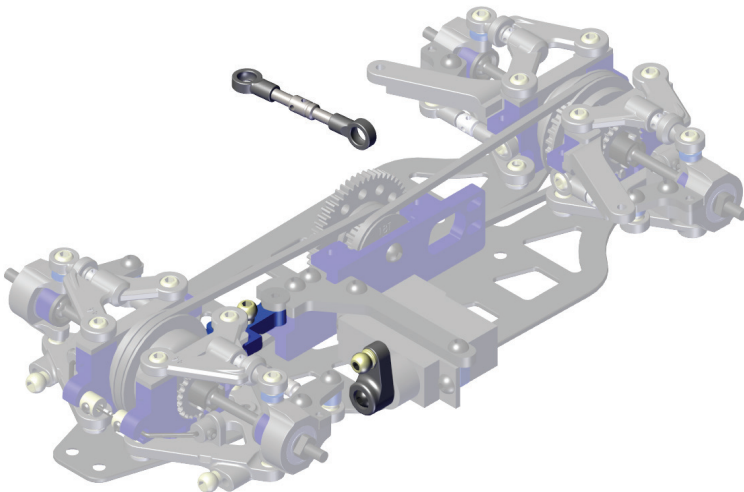

21479 x2
 TC28
 Rod End

21479
 TC28
 Turnbuckle
 18mm

Note:
 Notch indicates left hand thread. Install notch on left side of car.

Note:
 Pinch ballcups on pivot ball with pliers lightly if tight.

12.75mm

Bag 6 - Step 4

Motor
 * Not Included

21666 x2
 2x5mm
 BHCS

64P Pinion
 and Set Screw
 * Not Included



21690
 RC28R FT
 Aluminum
 1:28 Scale
 Pinion Gear
 Set, 9-11
 Tooth - 64p



21691
 RC28R FT
 Aluminum
 1:28 Scale
 Pinion Gear
 Set, 12-14
 Tooth - 64p

21667 x6
 2x4mm
 FHCS

21483 x2
 TC28
 Top Deck

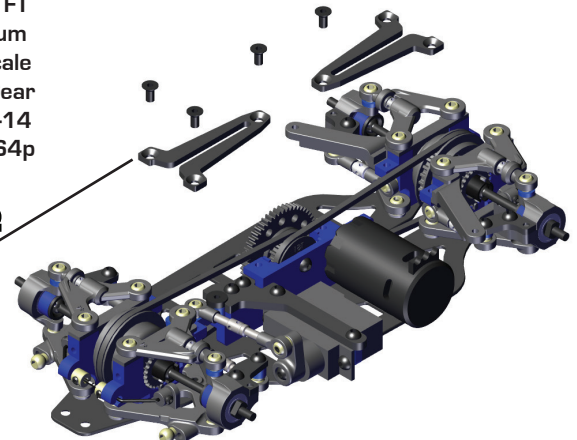

Bag 7 - Step 1

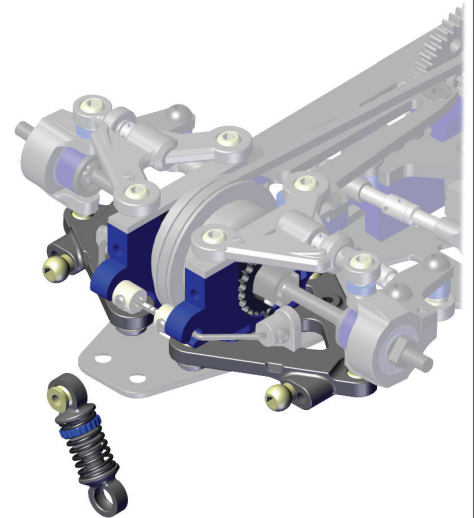
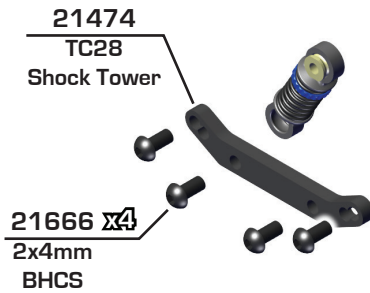
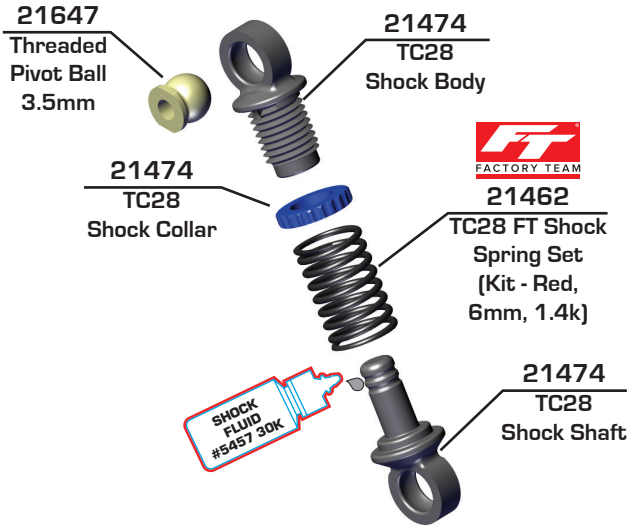

Build Left and Right Side

Bag 7 - Step 2

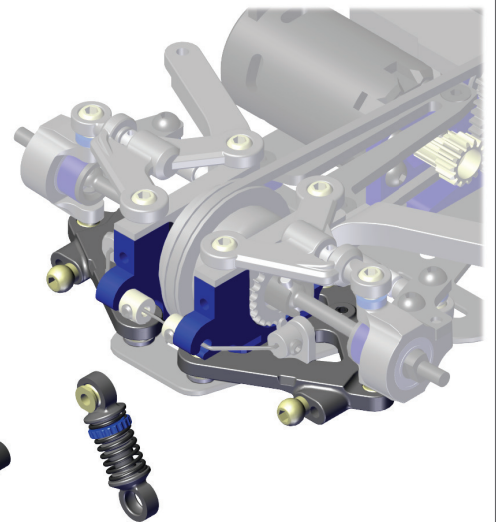
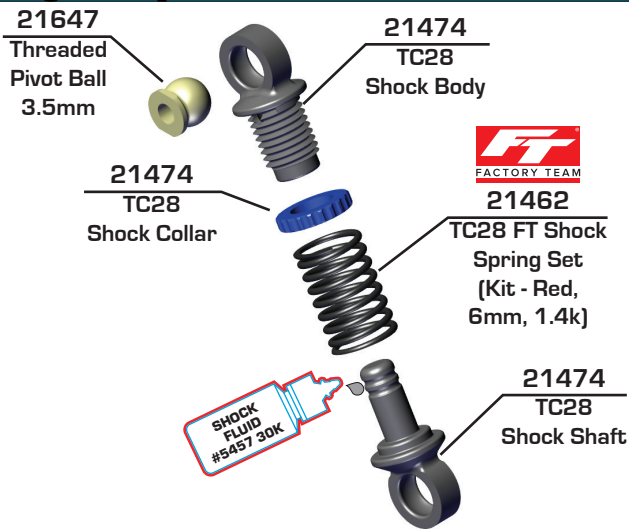

Build Left and Right Side

Bag 8 - Step 1

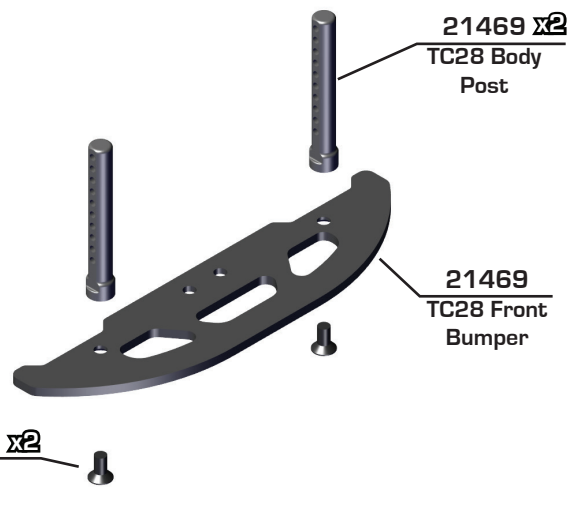
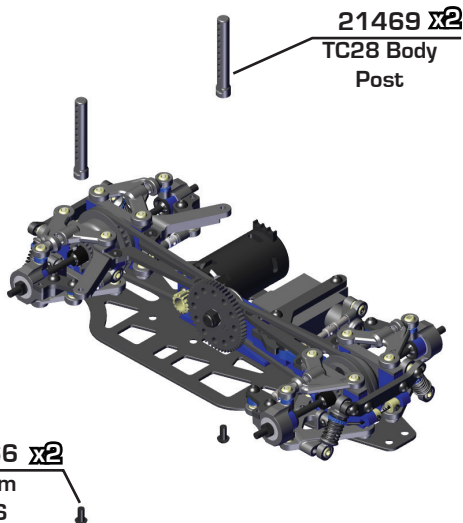

Bag 8 - Step 2

21486 x2
TC28 Battery
Mount Standoff

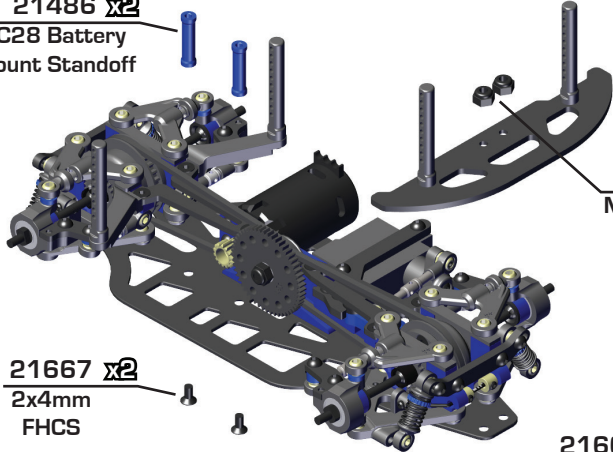

21689 x2
M2 Locknut,
Aluminum

21667 x2
2x4mm
FHCS

21667 x2
2x5mm
FHCS



Note:
Use included long plate
for 24mm wide batteries.

21673 x2
2x6mm
BHCS

21486
TC28 Battery
Mount Plate
(2)

21486
TC28 Battery
Mount Plate
(1 - Short)

21689 x2
M2 Locknut,
Aluminum

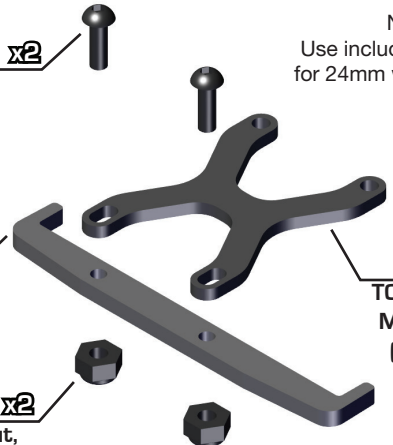

Bag 8 - Step 3

21666 x2
2x4mm
BHCS

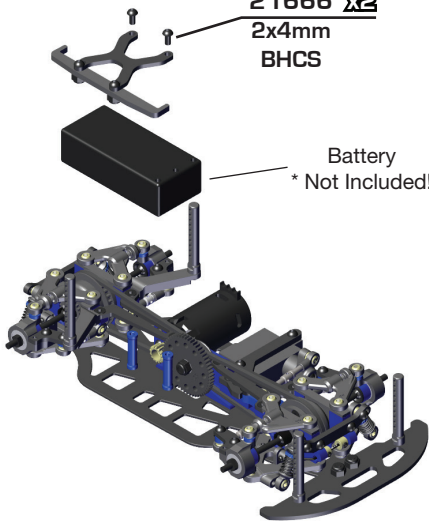

Battery
* Not Included!

ESC and Receiver
*Not Included!

6727 x2
Servo Tape

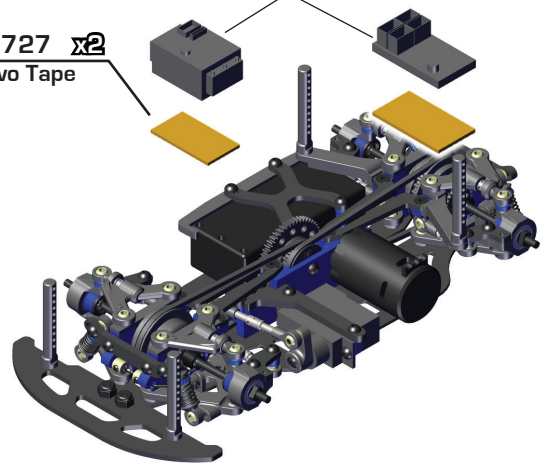

Bag 8 - Step 4



Install body with the
O-Rings 1st, then body,
then body clips.

21469 x4
Body Post
O-Ring

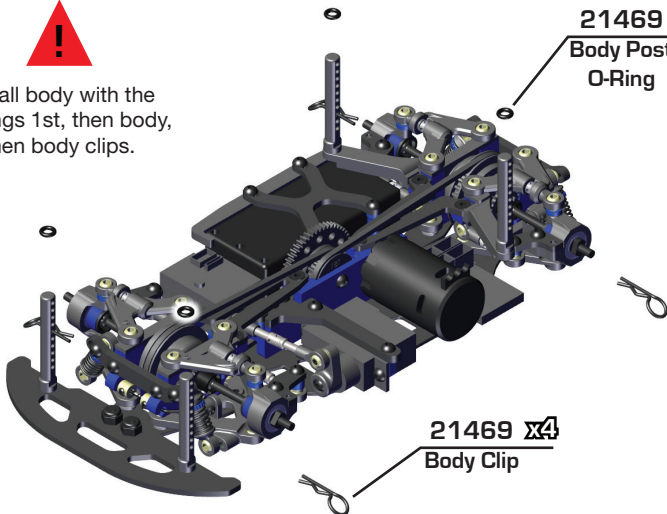

21469 x4
Body Clip



Note:
Adjust the body height
depending on body used.



Mako X Body

FRONT

REAR

:: Bag Tires / Wheels - Step 1

21478
TC28 Tire Set, Front (OD 25mm)

21478
TC28 Tire Set, Rear

21466
TC28 Wheel Set, White

OPTIONAL 21467
TC28 Wheel Set, Yellow

21466
TC28 Wheel Set, White

21689 x4
M2 Locknut, Aluminum

Note:
Do not over-tighten wheel nuts.
Use CA glue or tire tape to mount tires to wheels.

:: Body - 1

Body Mounting:
1. Use the existing front hole dimples.

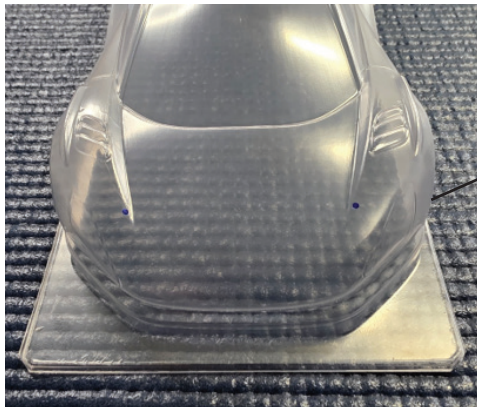

21695
Radboddy Mako X, Clear Body

2. Mark rear body post holes – 2.5mm further forward (from center) than existing rearward most dimples.



:: Body - 2

3. Cut off excess polycarbonate along bottom edge of body. Check that your marks line up with body posts before reaming holes.

Paint mask and body decals included.
Trim wheel wells to clear wheel and tires as needed.



Wing Mounting:

1. Cut out the wing along the outer lines. Trim wing down as desired for tuning.
2. Mount the wing by reaming existing dimples (front set of dimples suggested).

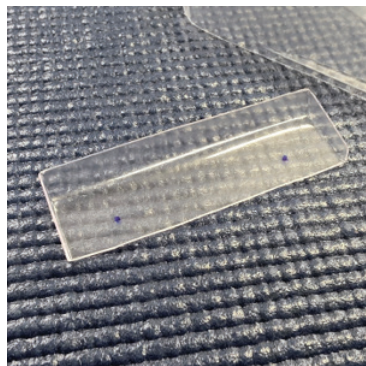

3. Use reamed holes on the wing as a guide for reaming mounting holes on the body. Take care to center the wing side to side and keep it square.
4. Use included mounting hardware.

*Note that both the wing and body have overspray masking which should be removed before final assembly and adding decals.

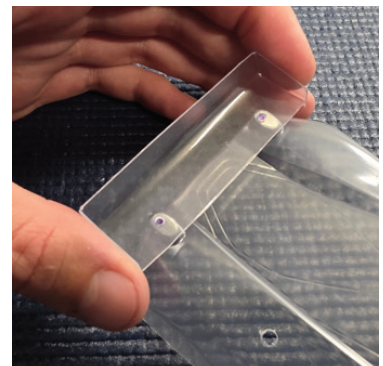



Associated Electrics, Inc.
21062 Bake Parkway Lake Forest, CA 92630 USA

call: (949) 544-7500 - fax: (949) 544-7501
Check out the following web sites for all of our kits, current products,
new releases, setup help, tips, and racing info!
www.AssociatedElectrics.com

FOLLOW US ON SOCIAL MEDIA



TeamAssociated
ReedyPower
ElementRC
FactoryTeam51



@TeamAssociatedRC
@ReedyPower
@Element_RC
@FactoryTeam_RC



@Team_Associated
@ReedyPower



@Associated_Electrics



TeamAssociatedRC
ElementRC



TeamAssociated
Reedy
Element-rc