

SR10

1:10 Scale Ready-To-Run 2WD
Electric Dirt Oval Race Car



#70030 SR10 Dirt Oval Race Car

- 1/10 SCALE VEHICLE
- 2 WHEEL DRIVE
- ELECTRIC POWERED
- ON ROAD
- OFF ROAD
- PRE PAINTED
- 2.4GHZ INCLUDED
- RTB READY TO RUN



**BRUSHLESS
POWERED
READY-TO-RUN**

1:10 Scale Ready-To-Run 2WD Electric Dirt Oval Race Car Manual & Catalog



:: Introduction

Thank you for purchasing this Team Associated product. This assembly manual contains instructions and tips for building and maintaining your new RTR. Please take a moment to read through this manual to help familiarize yourself with these steps. We are continually changing and improving our designs; therefore, actual parts may appear slightly different than in the illustrations. New parts will be noted on supplementary sheets.

:: KIT Features

- 2.4GHz 2-channel radio with new DVC (Dynamic Vehicle Control) receiver featuring built-in adjustable gyro
- High-torque, metal-gear Reedy Servo with spring style servo saver
- Powerful Reedy 3300kV brushless motor
- Water-resistant high-power Reedy brushless speed control with T-plug connector and LiPo low voltage cutoff
- Water-resistant enclosed receiver box
- Factory-finished Street Stock body with integrated rear spoiler
- Lightweight street stock inspired wheels
- High grip tires with street stock inspired tread pattern
- Durable and lightweight aluminum top shaft
- Low center-of-gravity molded composite chassis with hook-and-loop battery straps that accommodate both NiMH and 2/3s LiPo battery packs
- Metric hardware throughout
- 22 precision rubber-sealed ball bearings
- Impact absorbing front and rear bumpers
- Adjustable body mounts
- Rear CVA drive shafts for more reliability
- Aluminum 12mm big bore coil-over shock absorbers
- 2.6:1 ratio gearbox with heavy-duty sealed gear differential and externally adjustable slipper clutch
- Rugged steel turnbuckles for adjustable camber and front toe-in
- Adjustable suspension geometry
- Vertical ball ends for roll center adjustments, front and rear
- Many Factory Team options already available!

:: Additional

Your new RTR comes factory assembled including radio gear, motor, and ESC. However, there are some items you will need to complete your kit (refer to catalog section for suggestions):

- AA-size batteries for transmitter (#302)
- Peak Detection Charger or LiPo Compatible Charger
- 6 cell NiMH battery pack or 2/3S LiPo battery pack w/High Current T Plug.

Tools included:

- Allen wrenches 1.5mm, 2.0mm

:: Other Helpful Items

- | | | |
|----------------------------------------------------------------|-----------------------------------------------------------------|----------------------|
| • Green Slime shock lube (AE # 1105) | • Cyanoacrylate glue (AE # 1597) | |
| • Thread Locking Compound (AE # 1596) | • Silicone Shock Fluid (Refer to catalog for complete listings) | |
| • Silicone Diff Fluid (Refer to catalog for complete listings) | • Body Scissors (AE # 1737) | |
| • 8 Piece Hex Driver Set | • FT Hex Wrenches (AE # 1650) | |
| • Hobby Knife | • Wire Cutters | • Soldering Iron |
| • Calipers or a Precision Ruler | • Reamer / Hole Punch | • Ride Height Gauge |
| • FT Nut Drivers (AE #1663 - 1668) | • Turnbuckle Wrench (AE #1114) | • Needle Nose Pliers |















Associated Electrics, Inc.
21062 Bake Parkway.
Lake Forest, CA 92630





Customer Service
Tel: 949.544.7500
Fax: 949.544.7501

:: Hardware - 1:1 Scale View





Button Head (bhcs)

-  **2x3mm (31509)**
-  **2x4mm (31510)**
Aluminum (8545)
-  **2.5x8mm (31521)**
-  **2.5x10mm (31522)**
-  **3x5mm (31530)**
-  **3x8mm (31532)**
-  **3x10mm (25211)**
-  **3x12mm (89202)**
Titanium (91583)
-  **3x14mm (25187)**
-  **3x16mm (89203)**
-  **3x22mm (25189)**
Titanium (91588)
-  **3x24mm (89204)**
Titanium (91589)
-  **3x26mm (89205)**
-  **3x30mm (91478)**

Cap Head (shcs)

-  **2.5x14mm (71032)**
-  **3x24mm (89225)**
-  **3x45mm (89279)**





Flat Head (fhcs)

-  **3x8mm (25201)**
-  **3x10mm (25202)**
Aluminum (8555)
-  **3x12mm (25203)**
-  **3x14mm (89208)**
-  **3x16mm (25204)**
Titanium (91596)

Set Screws

-  **3x3mm (25225)**



Shims and Washers

-  **Servo Mount Washer (7337)**
(.250 x .125 x .815)
-  **FT Ballstud Washer, Aluminum**
(0.5mm) (31381)
-  **FT Ballstud Washer, Aluminum**
(1mm) (31382)
-  **FT Ballstud Washer, Aluminum**
(2mm) (31383)

Clips

-  **E-clip 1/8 (6299)**



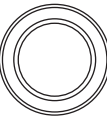





Ball Bearings

-  **3x7x3mm (91475)**
-  **5x10x4mm (25237)**
-  **6x13x5 (91562)**
-  **10x15x4 (91563)**

Ballstuds

-  **HD 6mm (91047)**
Titanium HD 6mm (91751)
-  **HD 8mm (91048)**
Titanium HD 8mm (91752)
-  **HD 10mm (91049)**
Titanium HD 10mm (91753)

Nuts (lock/plain)

-  **M2.5 Locknut, Shock Piston**
(89215)
-  **M3 Nut (91477)**
-  **M3 Alum. Locknut, Blue (31550)**
-  **M3 Locknut, Black (25215)**
-  **M3 Locknut w/Flange (25612)**
-  **FT 3mm Locknuts, Blue(25392)**
-  **M4 Serrated w/Flange (91738)**
-  **FT M4 Locknuts w/Flange,**
Blue (31551)

Notes:

:: Table of Contents

1..... Cover	13 - 14.....Gearbox Install
2..... Introduction	14 - 15.....Rear Hub and CVA Build
3.....1:1 Hardware "Fold Out"	15 - 16.....Turnbuckles Build
4..... Table of Contents	16 - 17.....Shocks Build
5 - 7.....Quick Start Guide	18 - 20.....Electronics Build
8.....Front Top Plate and Steering Build	20 - 21.....Bumpers and Chassis Braces Build
9 - 10.....Front Suspension Build	21 - 23.....Tires and Body Build
10 - 11.....Rear Suspension Build	23 - 24.....Tuning Tips
11 - 12.....Gear Differential Build	25 - 33.....Catalog
12 - 13.....Gearbox Build	34..... Back Cover
13.....Slipper Build	

:: Notes

This symbol indicates a special note or instruction in the manual.



This symbol indicates a Racers Tip.



There is a 1:1 hardware foldout page in the front of the manual. To check the size of a part, line up your hardware with the correct drawing until you find the exact size. Each part in the foldout has a number assigned to it for ordering replacement parts.

**Associated Electrics, Inc.
21062 Bake Parkway.
Lake Forest, CA 92630**



**Customer Service
Tel: 949.544.7500
Fax: 949.544.7501**

:: Quick Start Guide

Battery Charging Steps and Safety:

Remove the battery from the vehicle before charging.
Place battery on a fire resistant surface.
Avoid any contact with water or other liquids.
Be sure to select the correct charging mode for the type of battery you are charging.

ALWAYS use a compatible charger for charging your batteries.

Caution: Never leave the battery unattended while charging. Always disconnect the charger from the power source when finished charging.

Caution: Always disconnect the battery when you are finished driving the vehicle.



**Peak Detection
Quick Charger**

:: Quick Start Guide - (cont.)

Battery Installation:

1. Install the battery with the battery wires directed towards the front of the vehicle.
2. Secure the hook and loop strap near the rear shock tower. Pull the strap over the motor wires for added security.
3. Secure the hook and loop strap near the front shock tower.

You may move the foam pad to either the front or the rear of the battery compartment to adjust the weight balance of the vehicle.

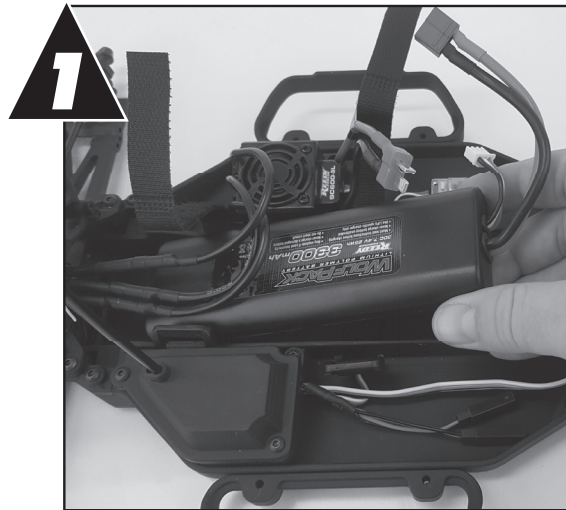

:: Quick Start Guide - (cont.)

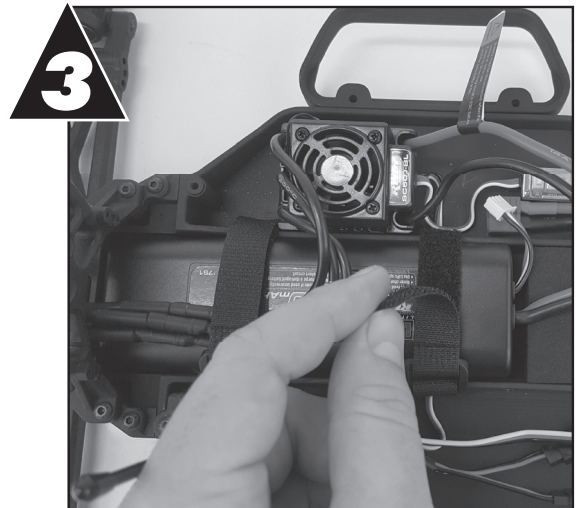
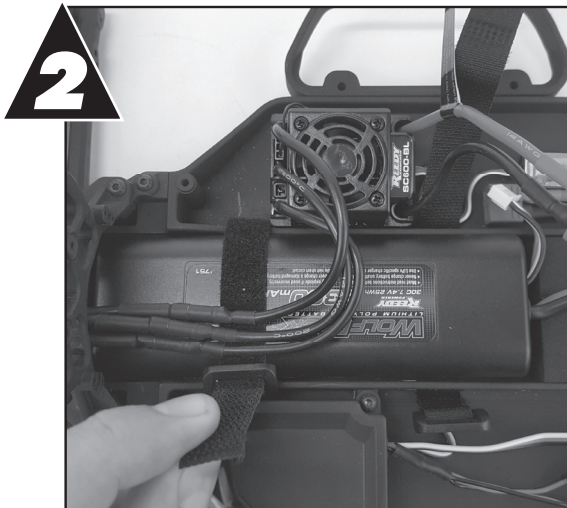

:: Quick Start Guide - (cont.)

Battery Notes and Tip:

Connect the battery as shown.
Disconnect the battery when not in use!

LiPo: LiPo batteries (lithium polymer) are high current rechargeable batteries. LiPo batteries offer extended run time and peak performance over NiMH batteries. They require a peak detection charger designed specifically for LiPo batteries. These batteries require special care and handling. LiPo batteries are recommended for advanced users only! **ALWAYS** charge a LiPo battery in LiPo mode.

If using a 3S LiPo battery, use a smaller pinion gear as a starting point (use part # 1335 17T Pinion). This provides the correct gear ratio required for the more powerful 3S LiPo battery. Gearing will depend on the surface you are running on, and the size of the track/area that you are driving in.

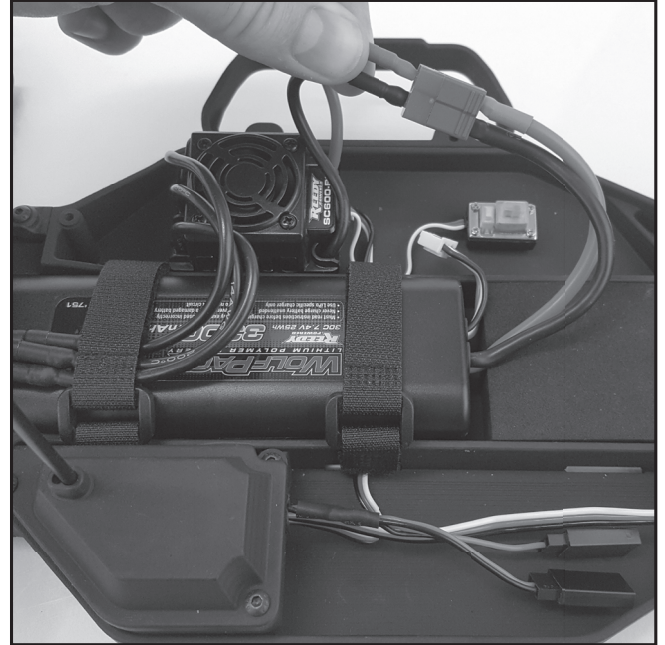

:: Quick Start Guide - (cont.)

Radio System Tuning and Controls:

RULE: Transmitter on First/Vehicle on Second,
Vehicle off First/ Transmitter off Last!

- 1) Slide the battery cover to remove cover.
- 2) Install alkaline or rechargeable AA size batteries into the battery holder.
- 3) Slide the battery cover back into place making sure it is completely closed and secure.
- 4) Turn the power ON. If the power indicator LED fails to light, check the batteries for insufficient contact or incorrect polarity.



On/Off Switch

:: Quick Start Guide - (cont.)

Radio System Tuning and Controls:

DO NOT hold the trigger when turning on the radio.

If using optional battery for transmitter, be sure to plug it in correctly. Plugging in a battery backwards can cause damage.

Refer to Radio owners manual for more in-depth instructions on radio operation and functions.

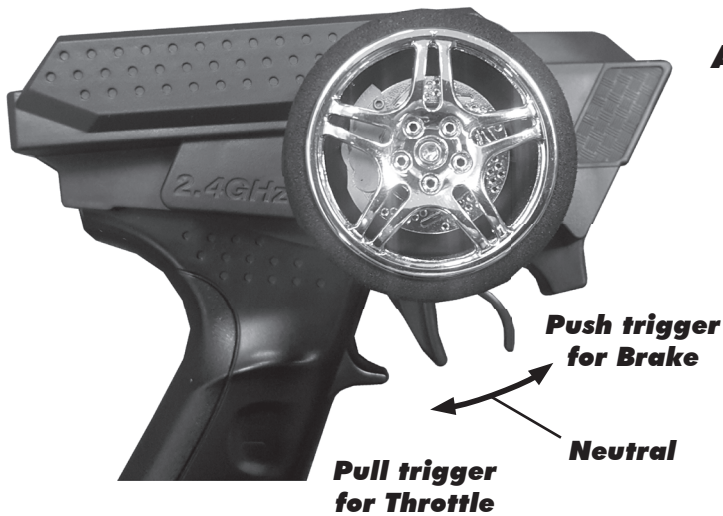

Adjust steering trim so front wheels point straight.

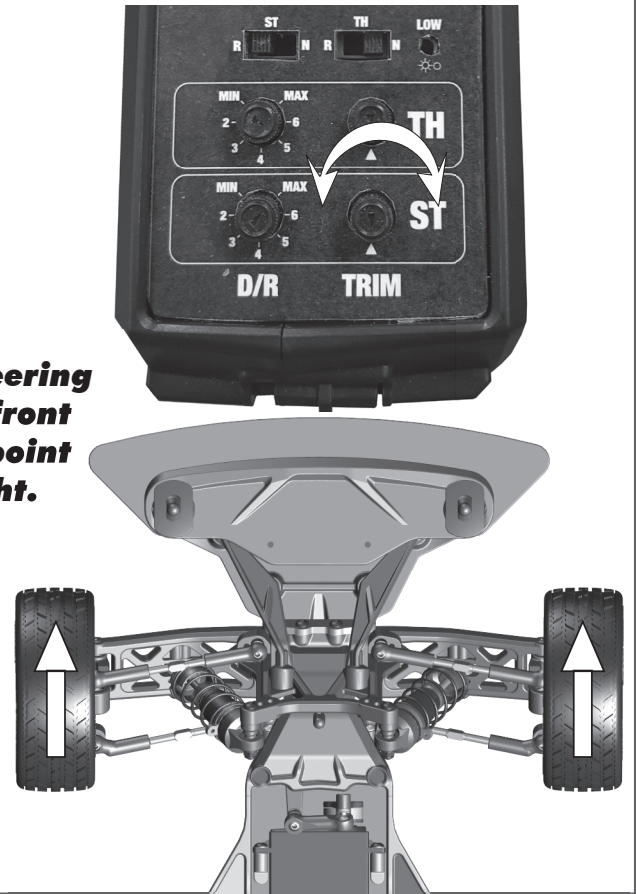

:: Quick Start Guide - (cont.)

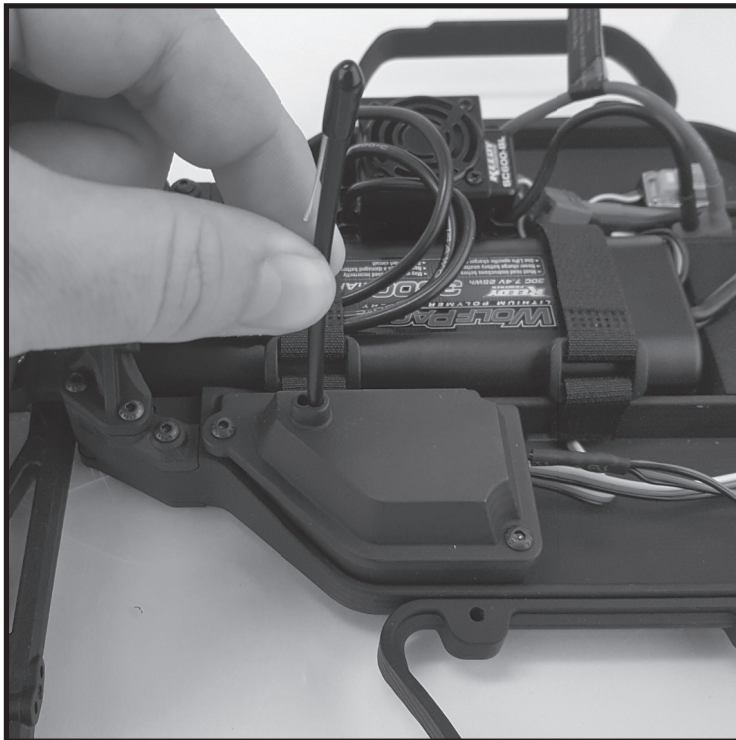

Install antenna wire through antenna tube, then install antenna tube as shown.

**Install body and body clips.
Ready to go!**

:: Front Top Plate and Steering Build - Step 1

91047 $\Sigma 2$
Heavy-duty Ballstud, 6mm

91475 $\Sigma 4$
3 x 7 x 3 Ball Bearing

91391
Steering Rack

91391 $\Sigma 2$
Steering Rack Crush Tube

91391
Steering Bellcrank Brace

89202 $\Sigma 2$
M3 x 12mm BHCS

91047
Heavy-duty Ballstud, 6mm

!
Note orientation of steering rack.

!
Do not overtighten steering bolts. Make sure there is free movement in the steering rack.

:: Front Top Plate and Steering Build - Step 2

91475 $\Sigma 4$
3 x 7 x 3 Ball Bearing

91391
Steering Bellcrank Brace

25189 $\Sigma 2$
M3 x 22mm BHCS

91358
Chassis Brace Set (Top Plate)

!
Note orientation of the brace.

:: Front Top Plate and Steering Build - Step 3

25202 $\Sigma 2$
M3 x 10mm FHCS

91359
Bulkhead

71092
Chassis

:: Front Suspension Build - Step 1

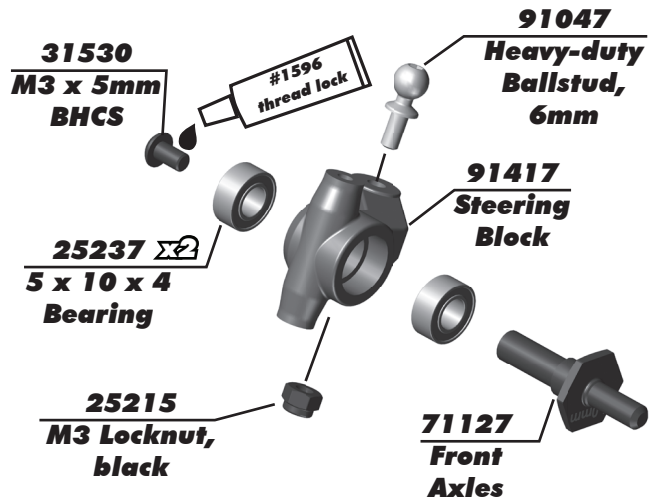

Build 2 (1 left, 1 right)

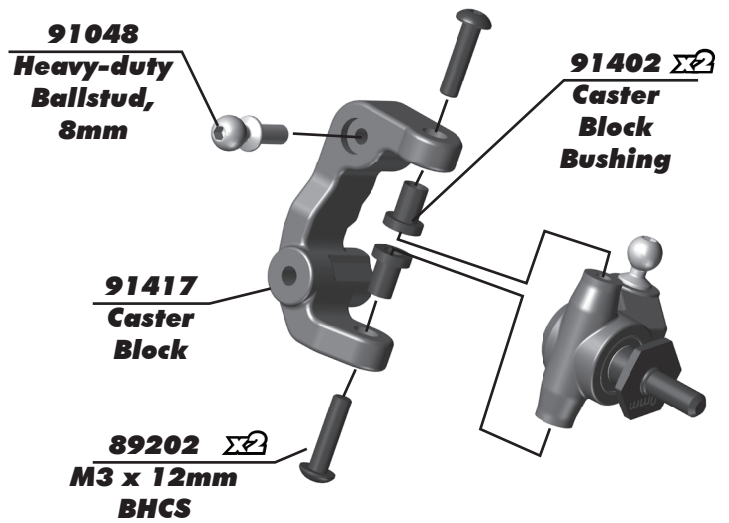

:: Front Suspension Build - Step 2

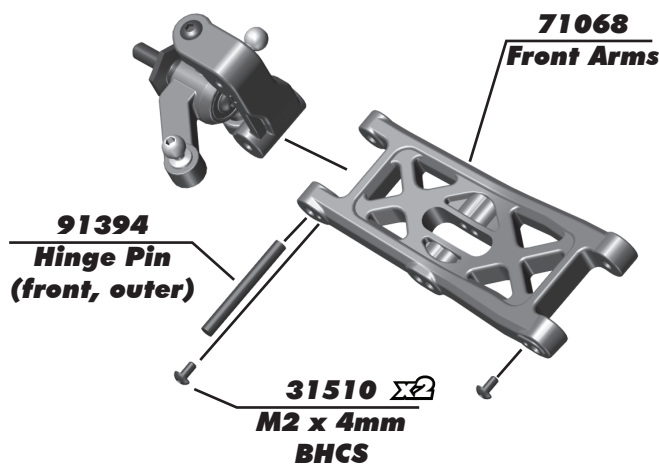

Build 2 (1 left, 1 right)

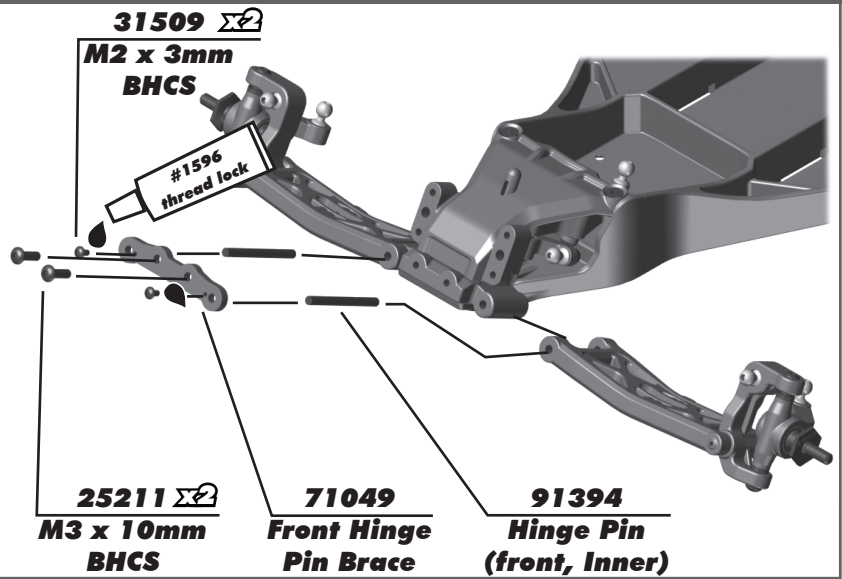

:: Front Suspension Build - Step 3

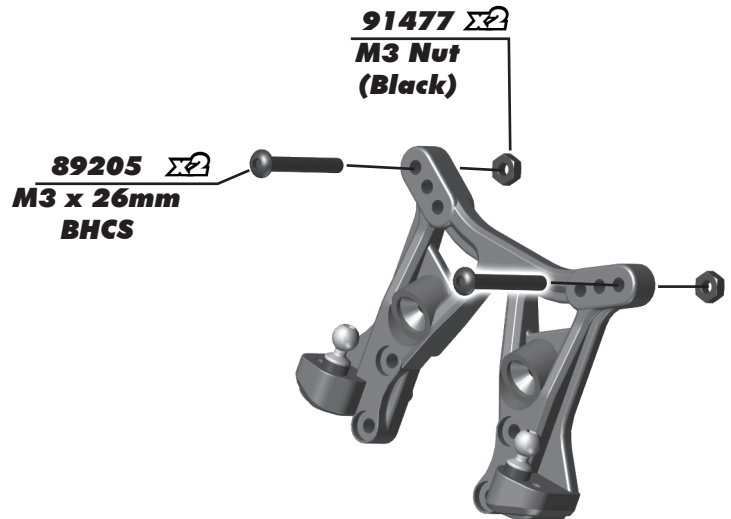
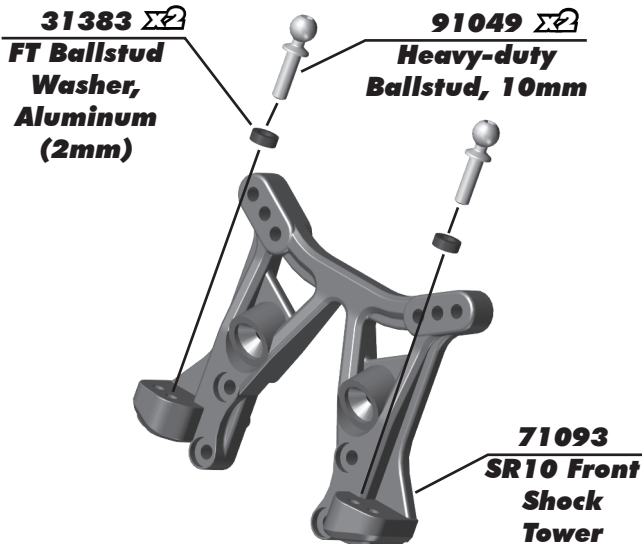

:: Front Suspension Build - Step 4

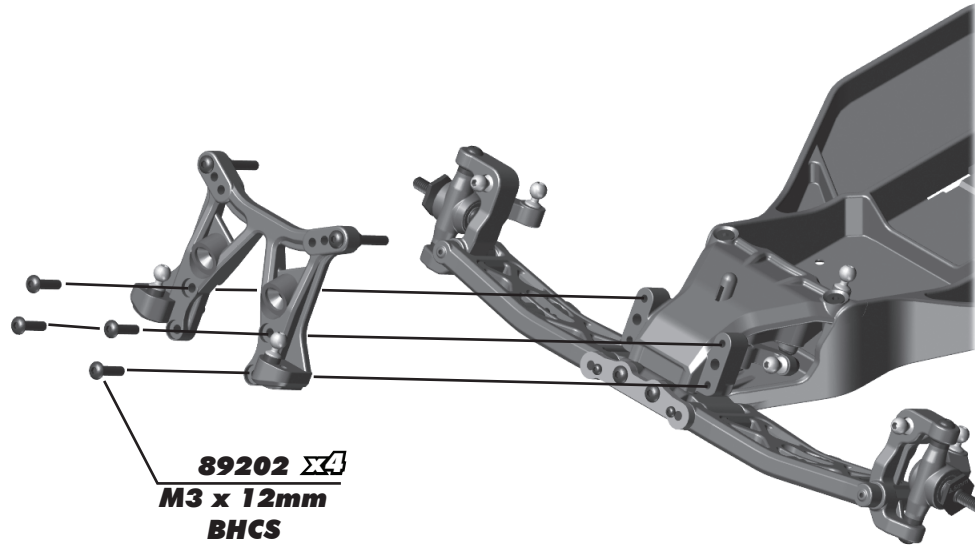

:: Rear Suspension Build - Step 1

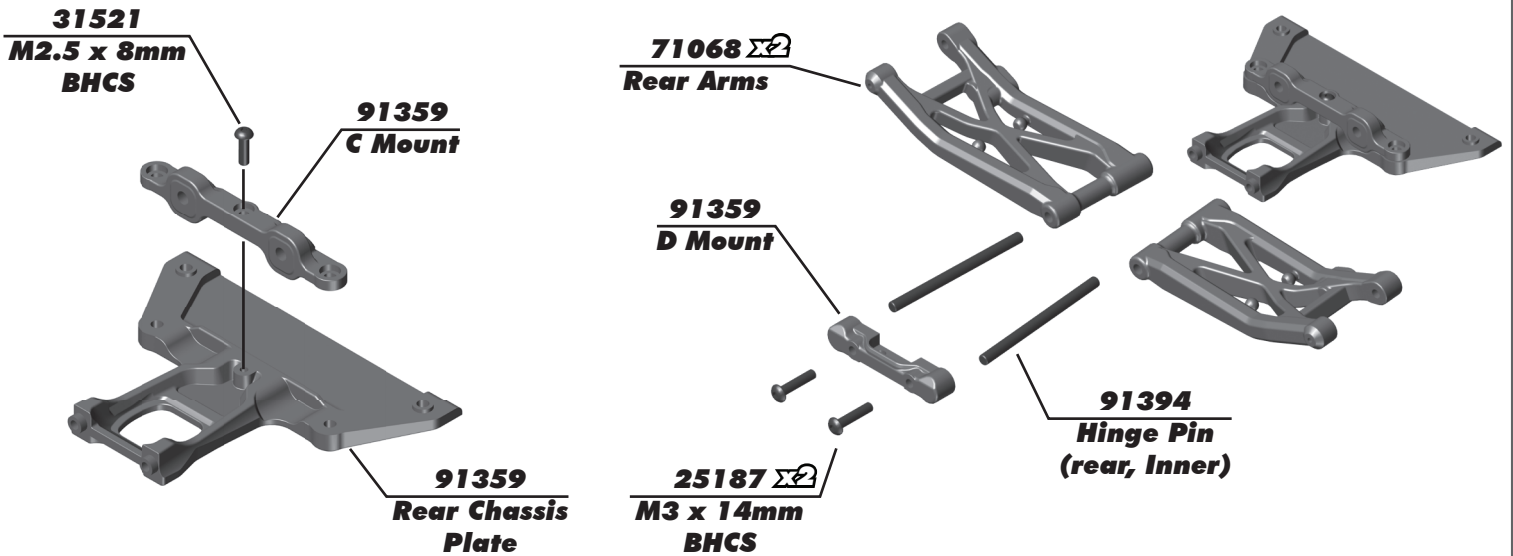

:: Rear Suspension Build - Step 2

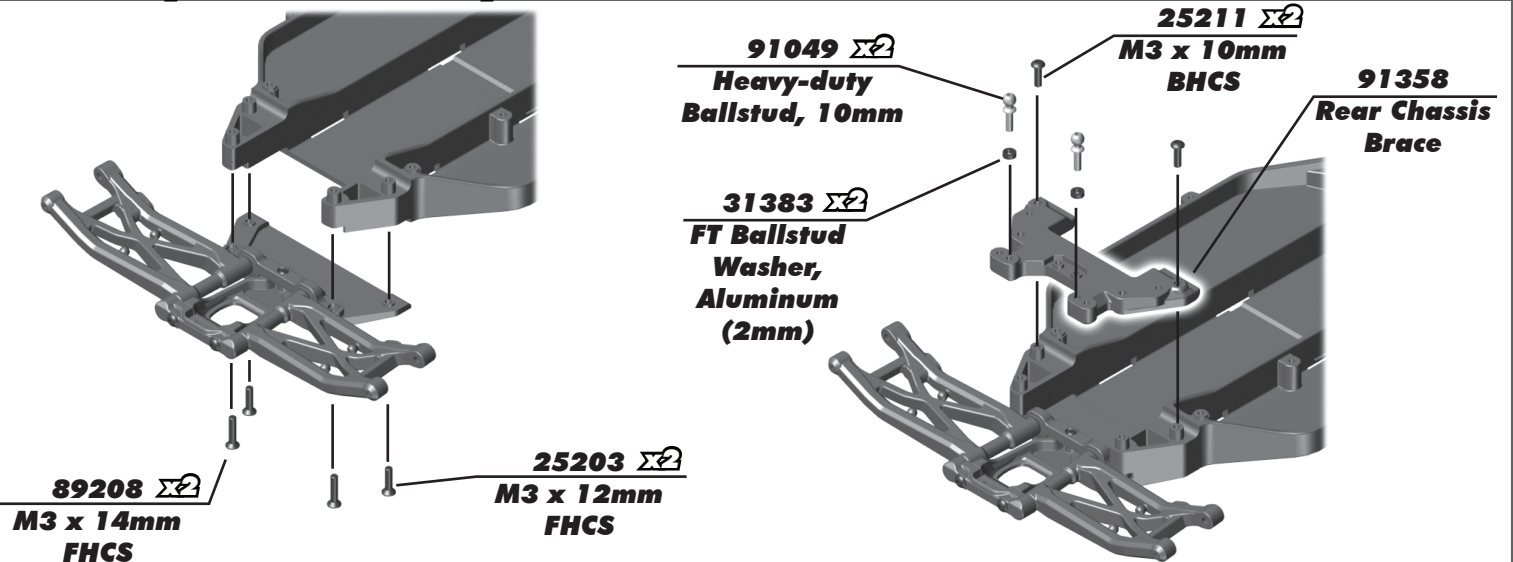

:: Rear Suspension Build - Step 3

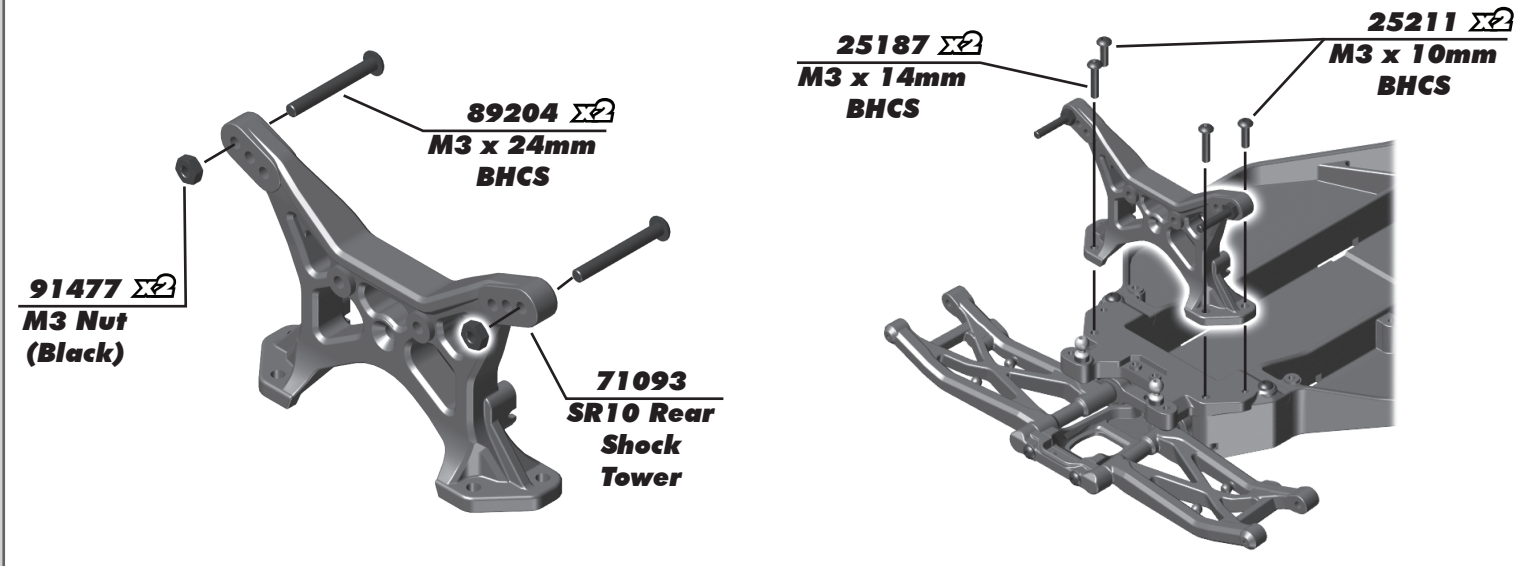

:: Gear Diff Build - Step 1

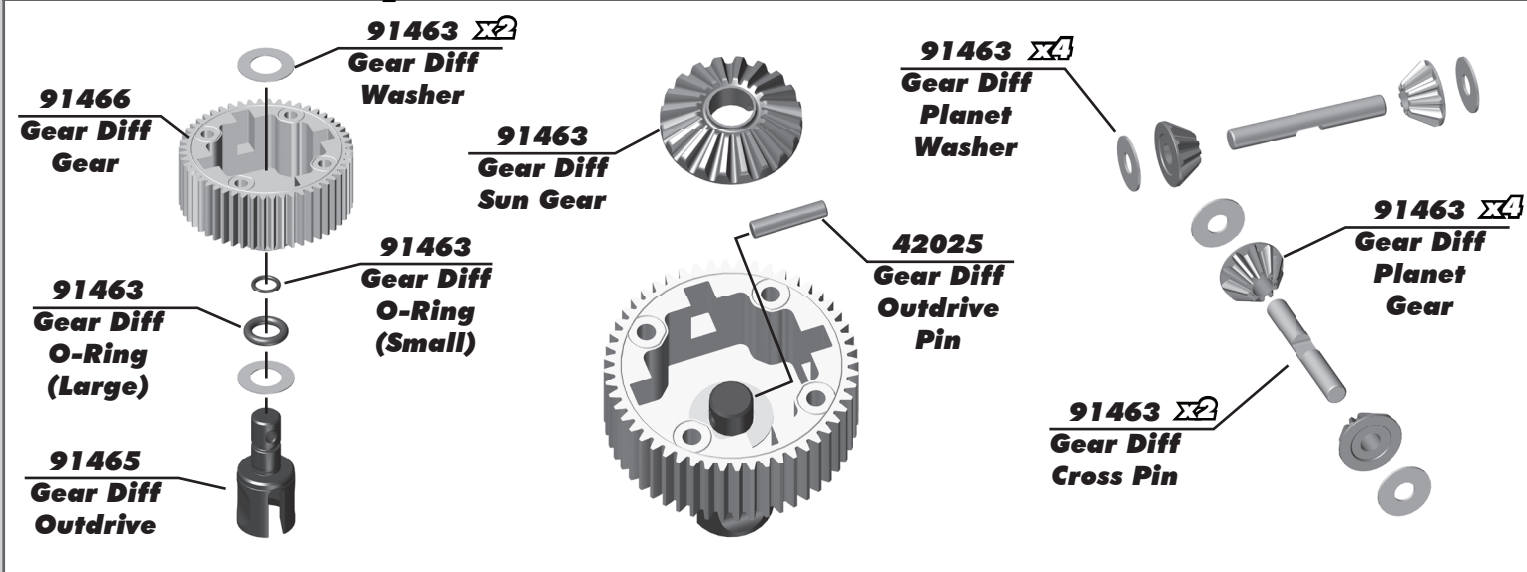

:: Gear Diff Build - Step 2

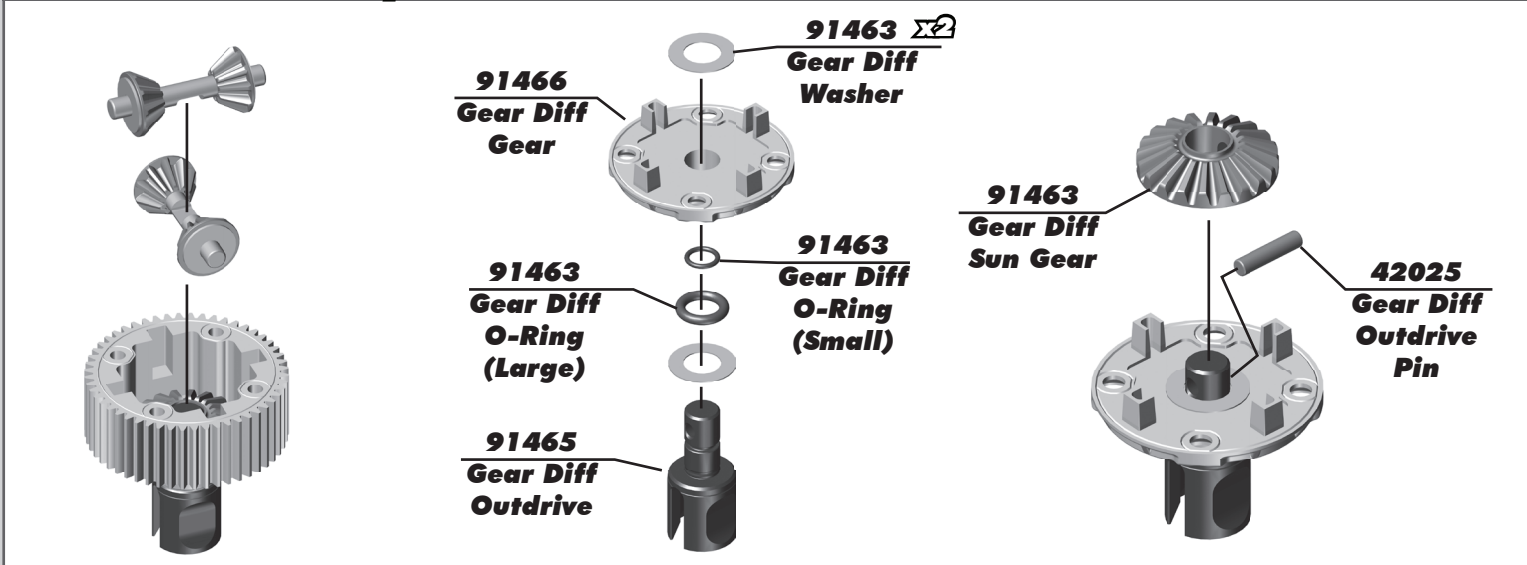

:: Gear Diff Build - Step 3

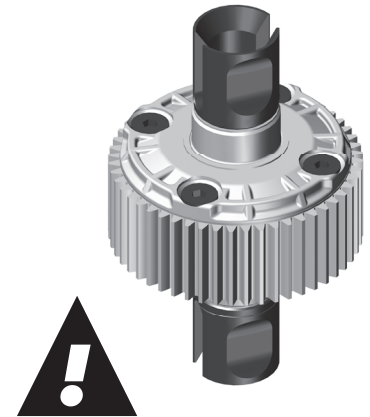
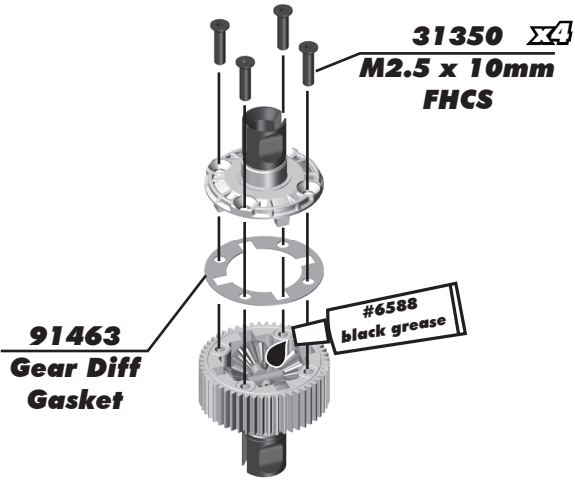

* Ensure free outdrive rotation before installation!

:: Gearbox Build - Step 1

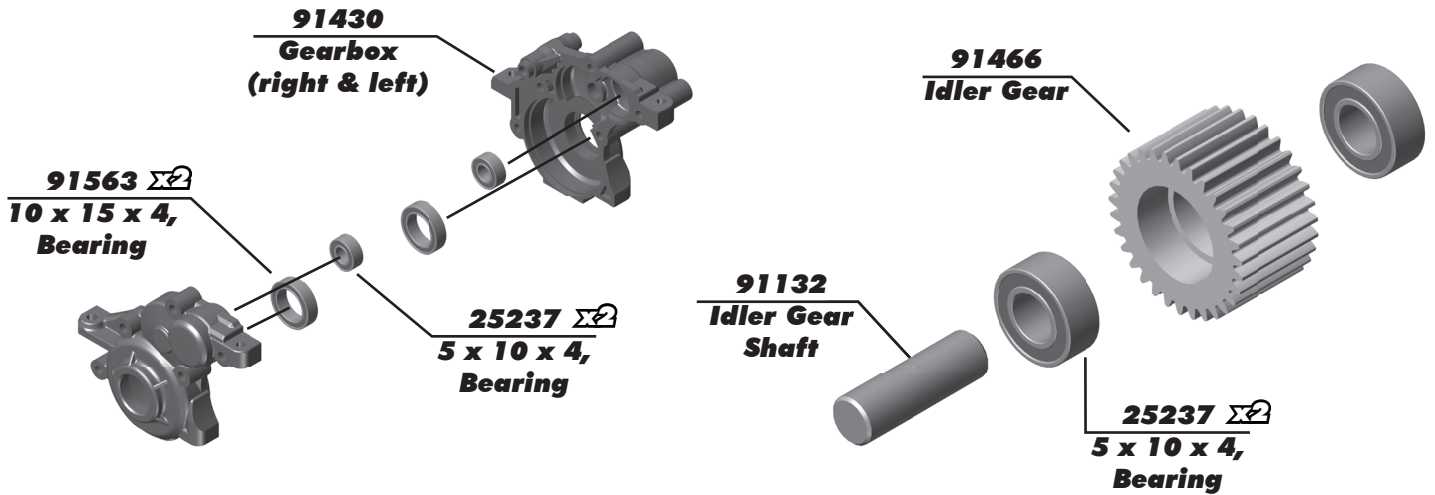

:: Gearbox Build - Step 2



Add a drop of Diff Lube (#6591) to the teeth of the diff gear, idler gears, and top shaft.

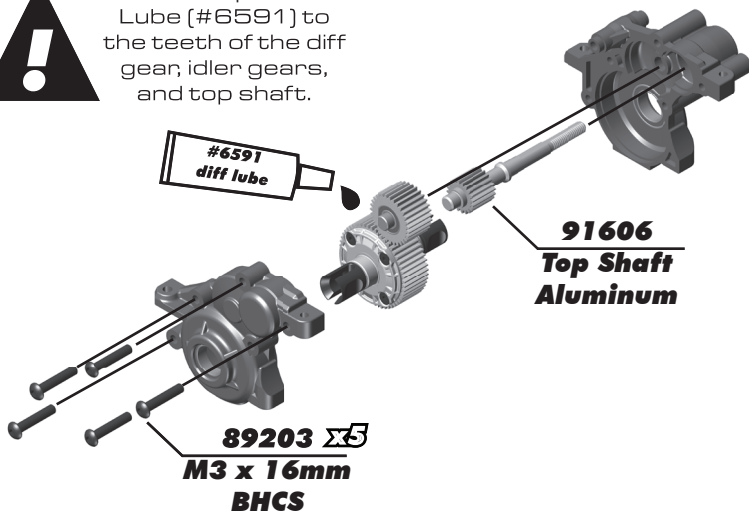

31532 Σ 2
M3 x 8mm
BHCS

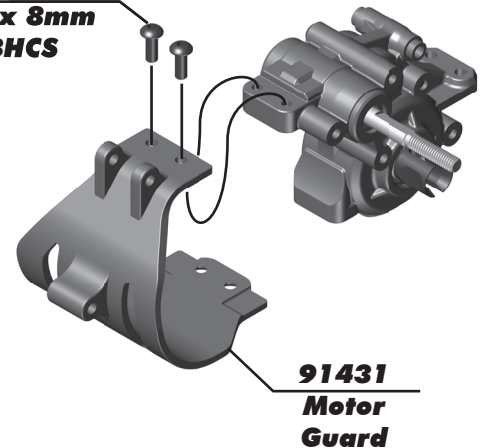

:: Gearbox Build - Step 3

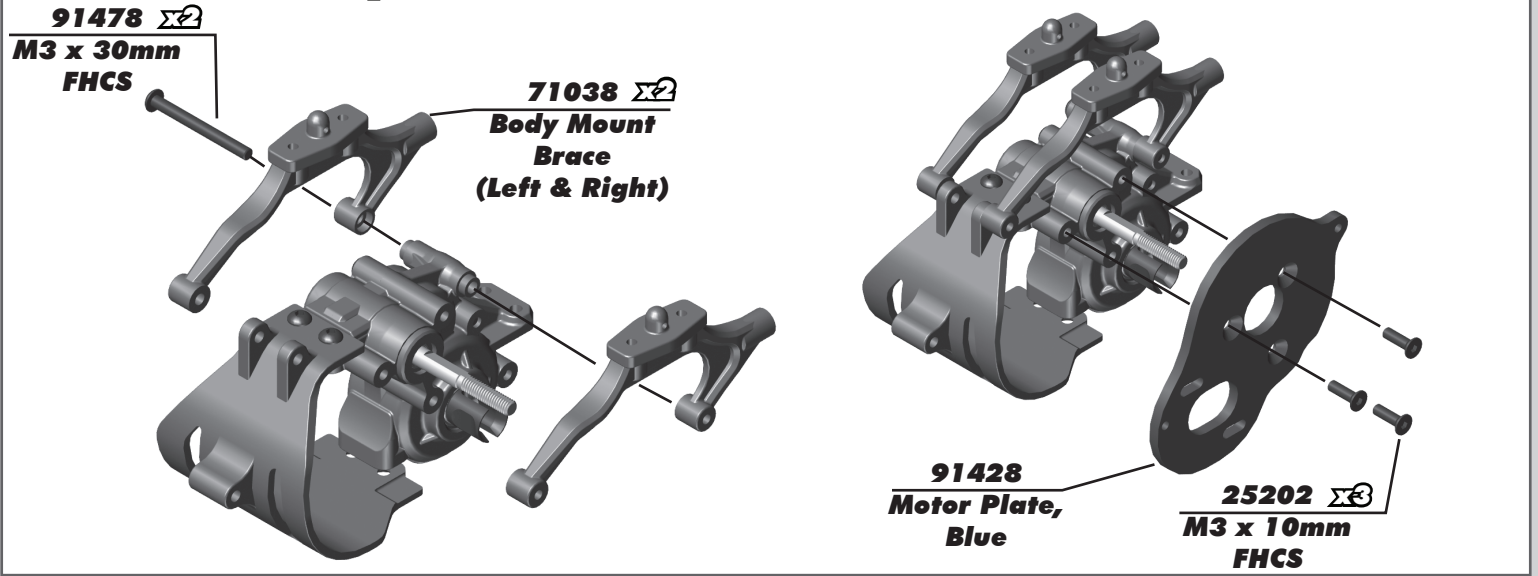

:: Slipper Build - Step 1

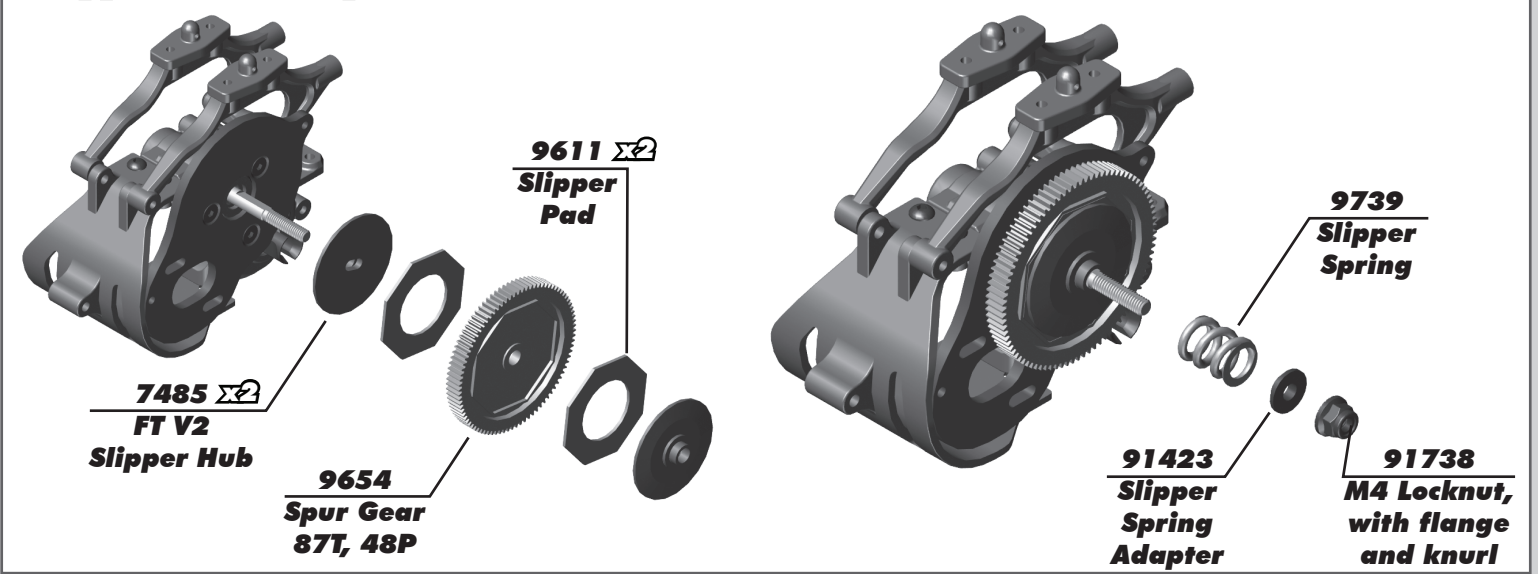

:: Gearbox Install - Step 1

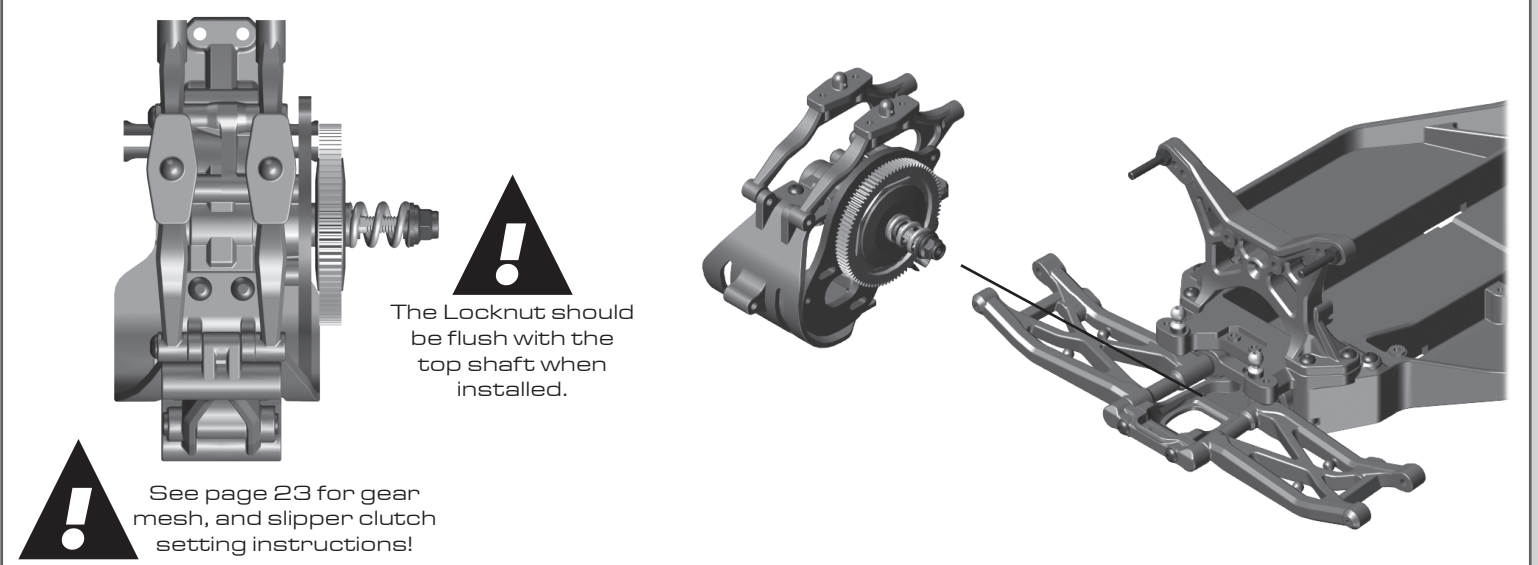

:: Gearbox Install - Step 2

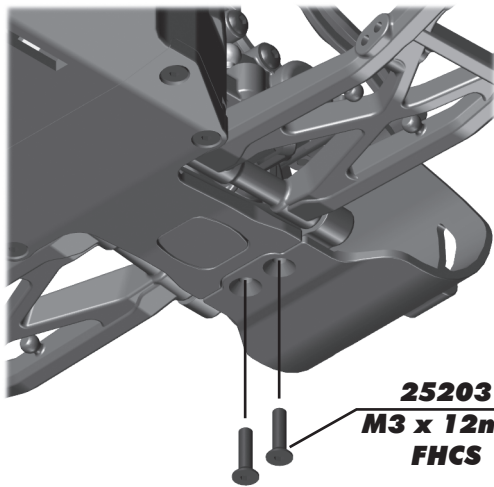

25203 $\Sigma 2$
M3 x 12mm
FHCS

25211 $\Sigma 2$
M3 x 10mm
BHCS

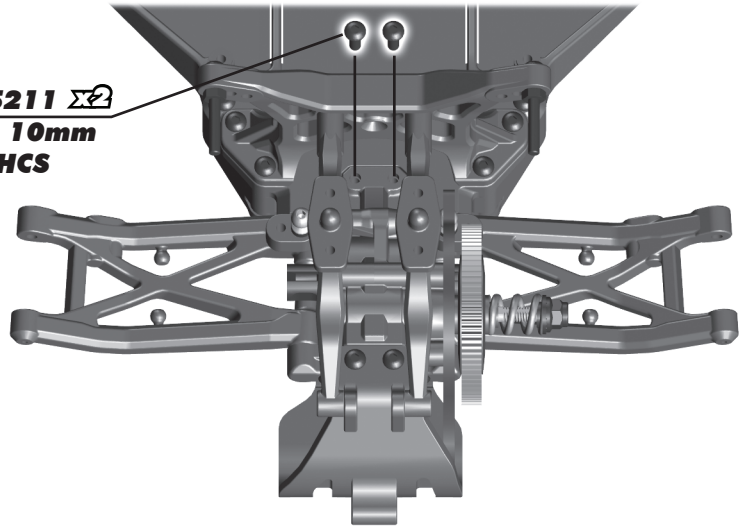

:: Gearbox Install - Step 3

25204 $\Sigma 2$
M3 x 16mm
FHCS

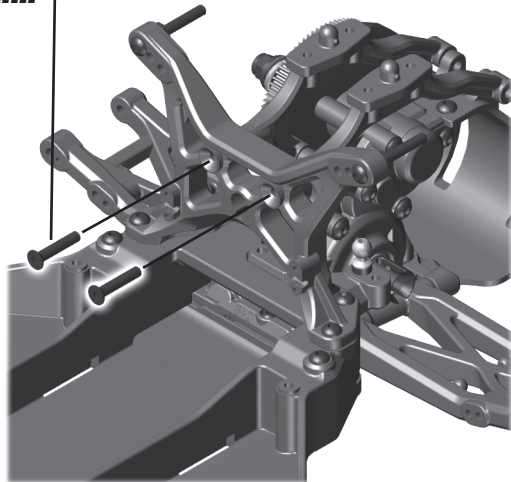

25202 $\Sigma 4$
M3 x 10mm
FHCS

71038
Rear Body
Mount

71066 $\Sigma 2$
Rear Body
Pivot

SR10

71066 $\Sigma 2$
Rear
Body Post

71032 $\Sigma 4$
M2.5 x 14mm
SHCS

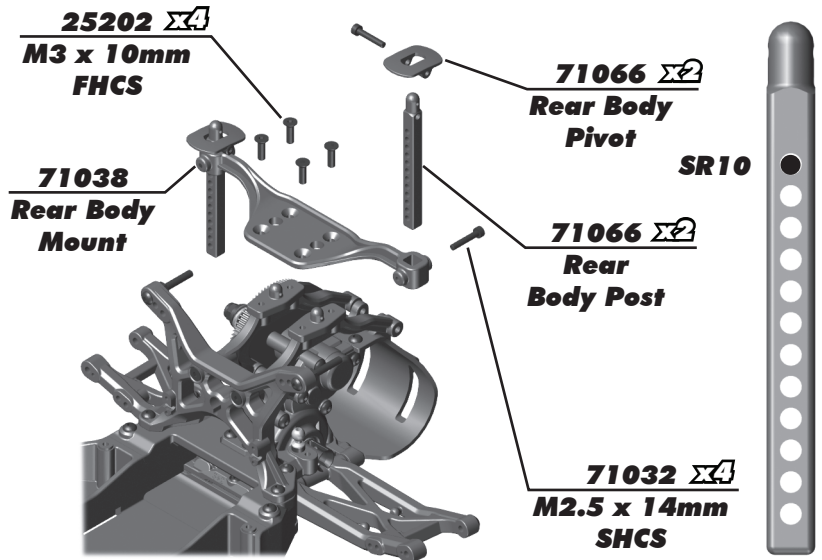

:: Rear Hub and CVA Build - Step 1

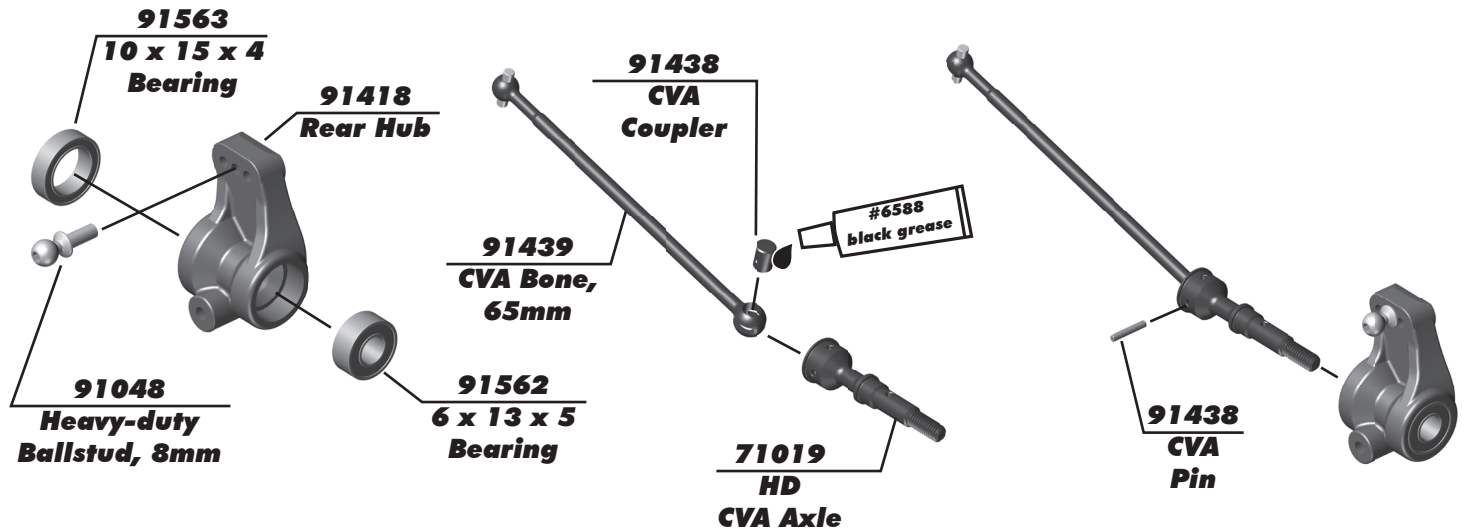

91563
10 x 15 x 4
Bearing

91418
Rear Hub

91438
CVA
Coupler

91439
CVA Bone,
65mm

#6588
black grease

91048
Heavy-duty
Ballstud, 8mm

91562
6 x 13 x 5
Bearing

71019
HD
CVA Axle

91438
CVA
Pin

Build x2 (right and left side)

Build x2 (right and left side)

:: Rear Hub and CVA Build - Step 2

91436
CVA Wheel
Hex Pin

91418
Wheel
Hex (rear)

31510
M2 x 4mm
BHCS

91394
Hinge Pin
(rear, outer)

Build x2 (right and left side)

:: Turnbuckles Build - Step 1

91722
Ball Cup

91723
Turnbuckles,
3x48mm

91722
Ball Cup

Steering Turnbuckle
28.00mm

Build x2 (right and left side)

!
Orient the notch to the left throughout the car. It indicates which end has the left hand threads!

Racers Tip:
Use black grease (#6588) on the threads of the turnbuckles for easier ball cup installation!

:: Turnbuckles Build - Step 2

91722
Ball Cup

91723
Turnbuckles,
3x48mm

91722
Ball Cup

Front Camber Turnbuckle
23.00mm

Build x2 (right and left side)

!
Orient the notch to the left throughout the car. It indicates which end has the left hand threads!

Racers Tip:
Use black grease (#6588) on the threads of the turnbuckles for easier ball cup installation!

:: Turnbuckles Build - Step 3

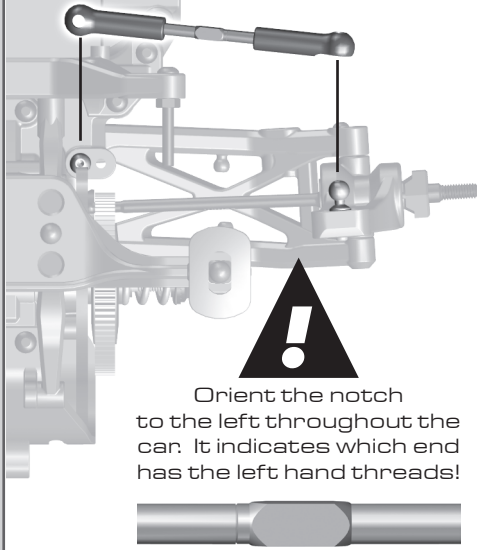

! Orient the notch to the left throughout the car. It indicates which end has the left hand threads!

91722
Ball Cup

91723
Turnbuckles,
3x48mm

91722
Ball Cup



Racers Tip:
Use black grease (#6588) on the threads of the turnbuckles for easier ball cup installation!

Rear Camber Turnbuckle

23.50mm



Build x2 (right and left side)

:: Shocks Build - Step 1

91444
12mm
Shock Piston

6299
1/8 E-Clip

91488
3 x 21
Shock Shaft
(front)

91489
3 x 27.5
Shock Shaft
(rear)

6299
1/8 E-Clip



Racers Tip:
Use a marker over the numbers on the pistons to make them easily visible!

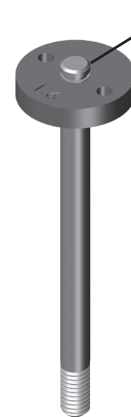
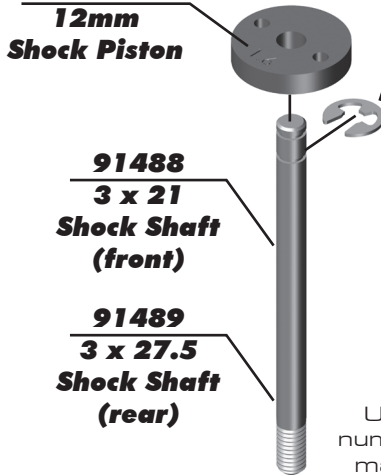

:: Shocks Build - Step 2

71191
Shock Body
12 x 23mm
(front)

71051
Shock Body
12 x 27.5mm
(rear)

91444
Shock
Internals

91454
Shock
Bottom Cap

! Lightly rub shock oil on the o-ring before installation!

31327
Shock
Bottom Cap
O-Ring

#1105
green slime

5407
O-Ring



Racers Tip:
Coating the o-rings with green slime (#1105) helps seal & reduce o-ring swell! **Green slime not included in kit!**

71086
6x6mm
Limiters

91491
Shock Cap
O-Ring

91469
Shock
eyelet

91469
Shock
Pivot Ball



Front

Rear

:: Shocks Build - Step 3

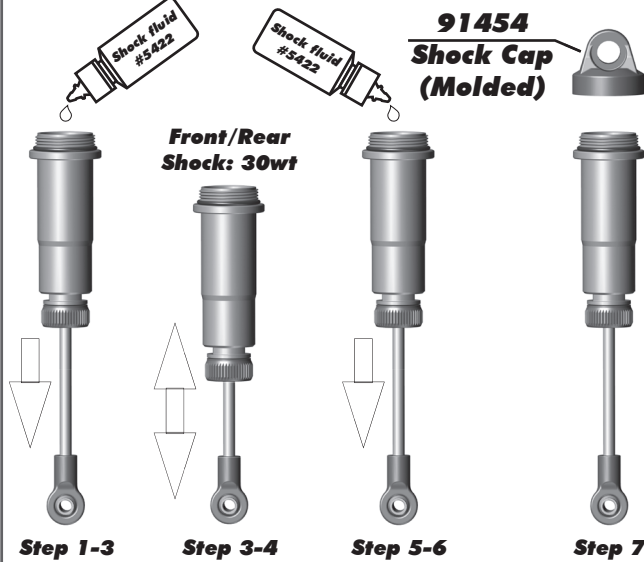

Shock Bleeding Steps:

1. Pull shock shaft down.
2. Fill shock body 3/4 full with silicone fluid.
3. Slowly move the shock shaft up and down to remove air from under piston. Wait for bubbles to come to surface.
4. Fill shock body to top with silicone fluid.
5. Place a drop of oil in the cap and on cap threads.
6. Install cap and tighten completely.
7. Slowly compress shaft all the way to the top. If there is pressure at the top of the stroke, there is too much oil or air. You must bleed it out.
8. Slowly pull shaft out.
9. Unscrew the cap 3/4 turn and tilt the shock at a slight angle.
10. Slowly compress the shaft to push out excess oil and air. You should see bubbles coming out from under the cap.
11. With the shaft compressed, tighten the cap and re-check for pressure at the top of the stroke. If there is still pressure, repeat steps 9 thru 11.

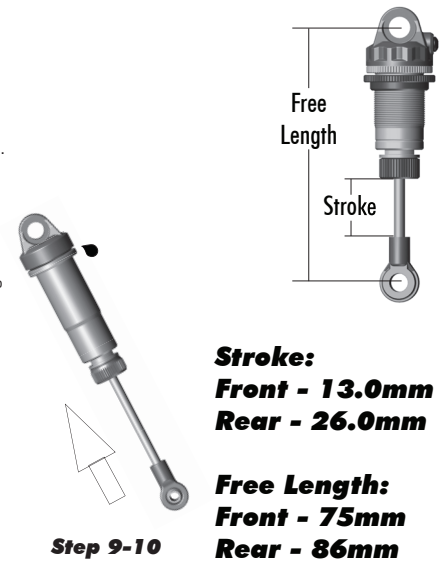

:: Shocks Build - Step 4

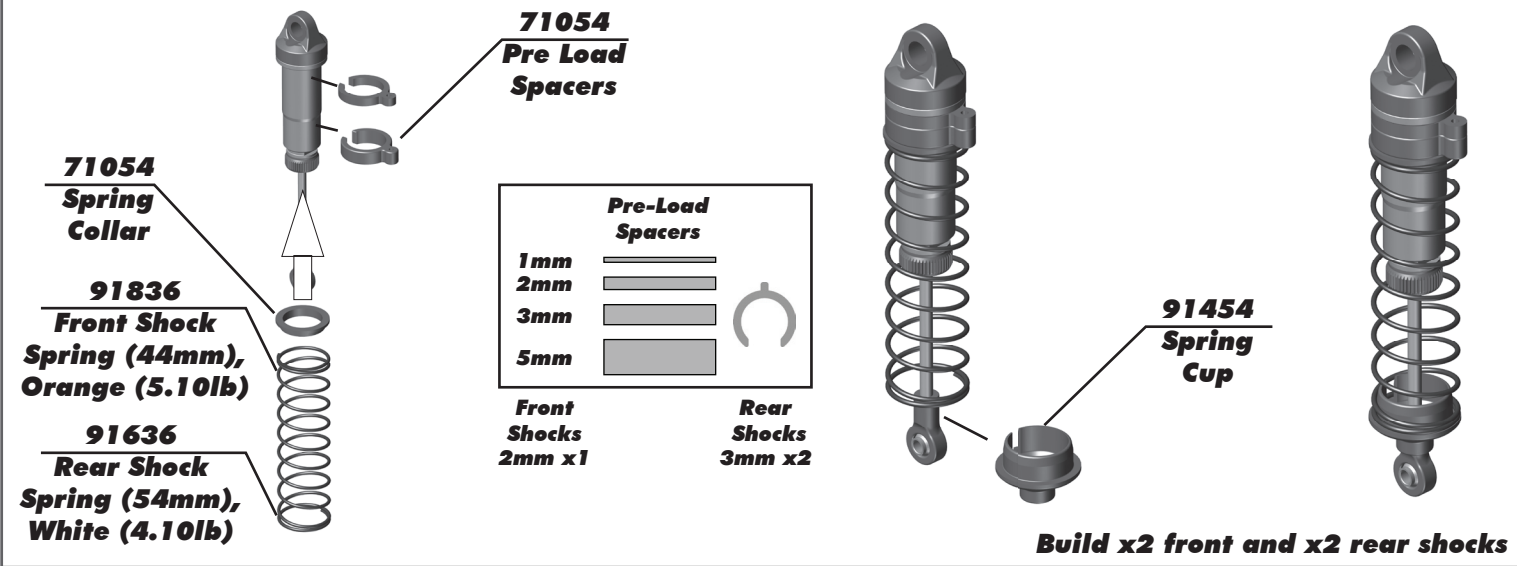

:: Shocks Build - Step 5

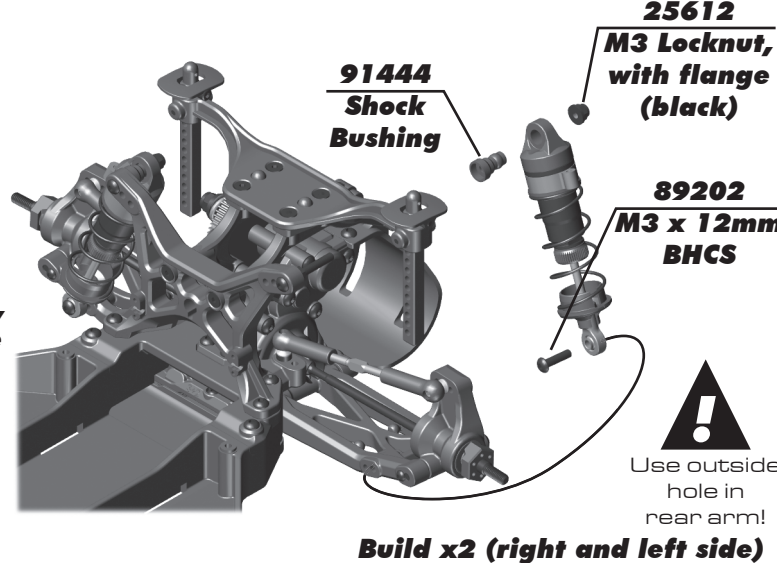
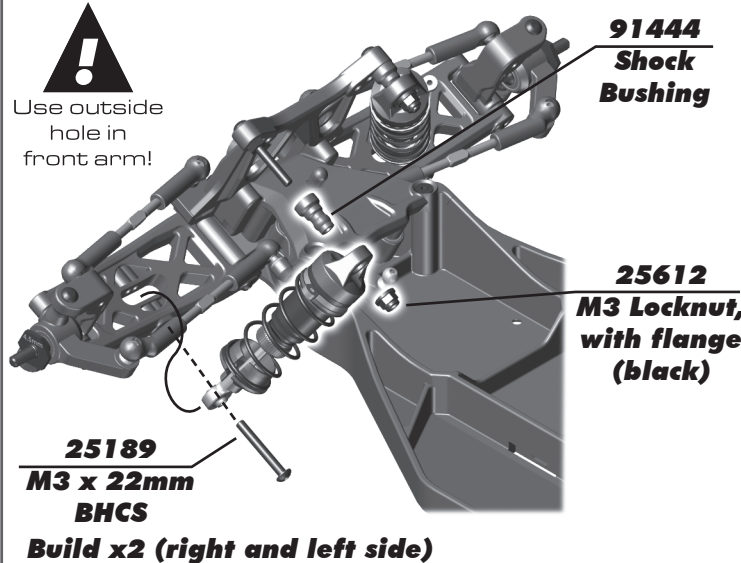

:: Electronics Build - Step 1

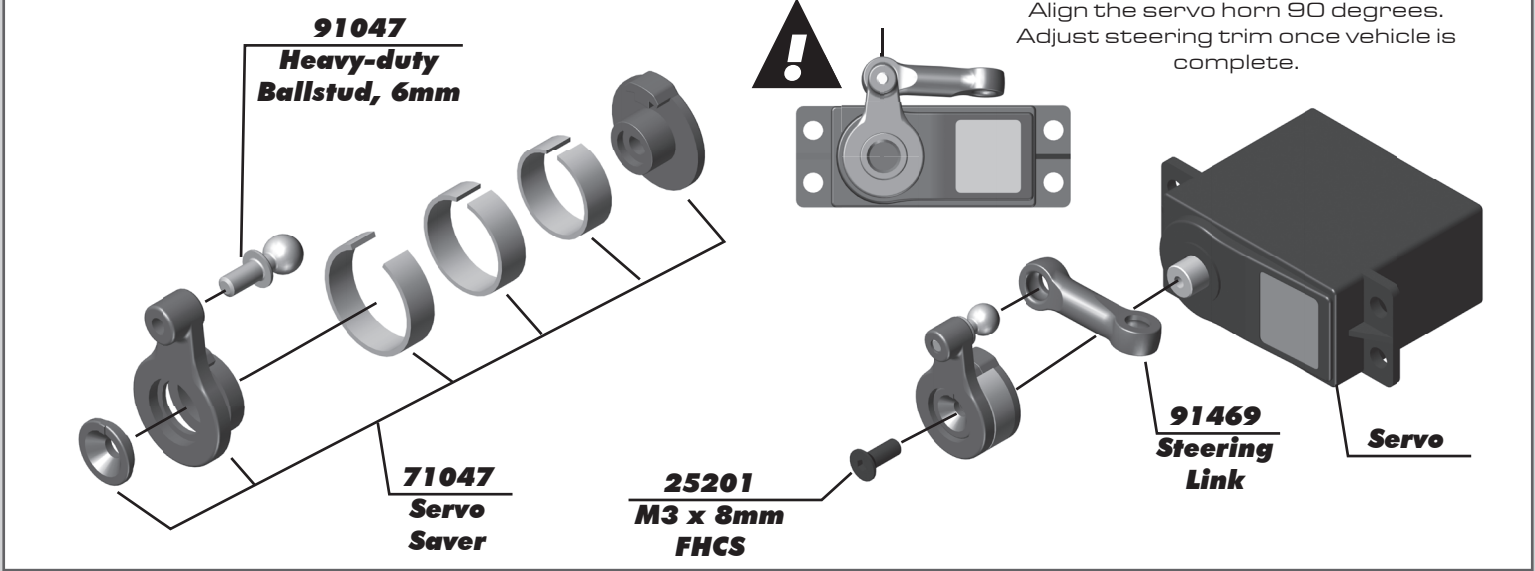

:: Electronics Build - Step 2

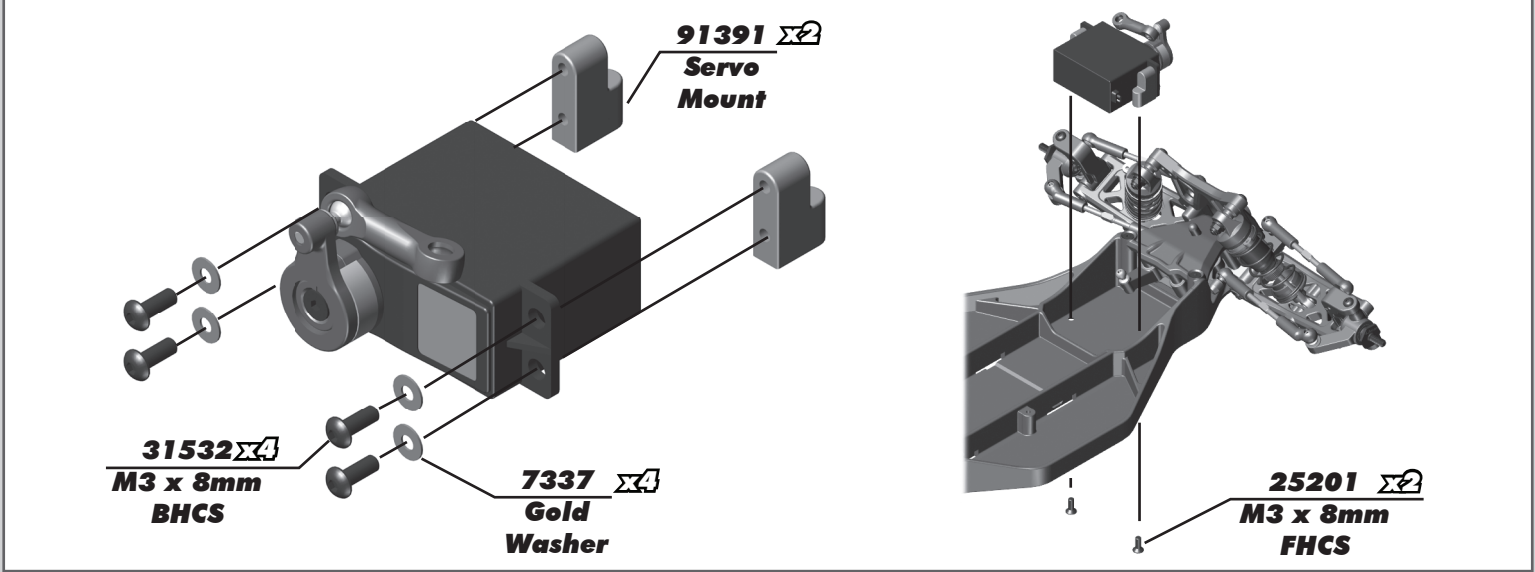

:: Electronics Build - Step 3

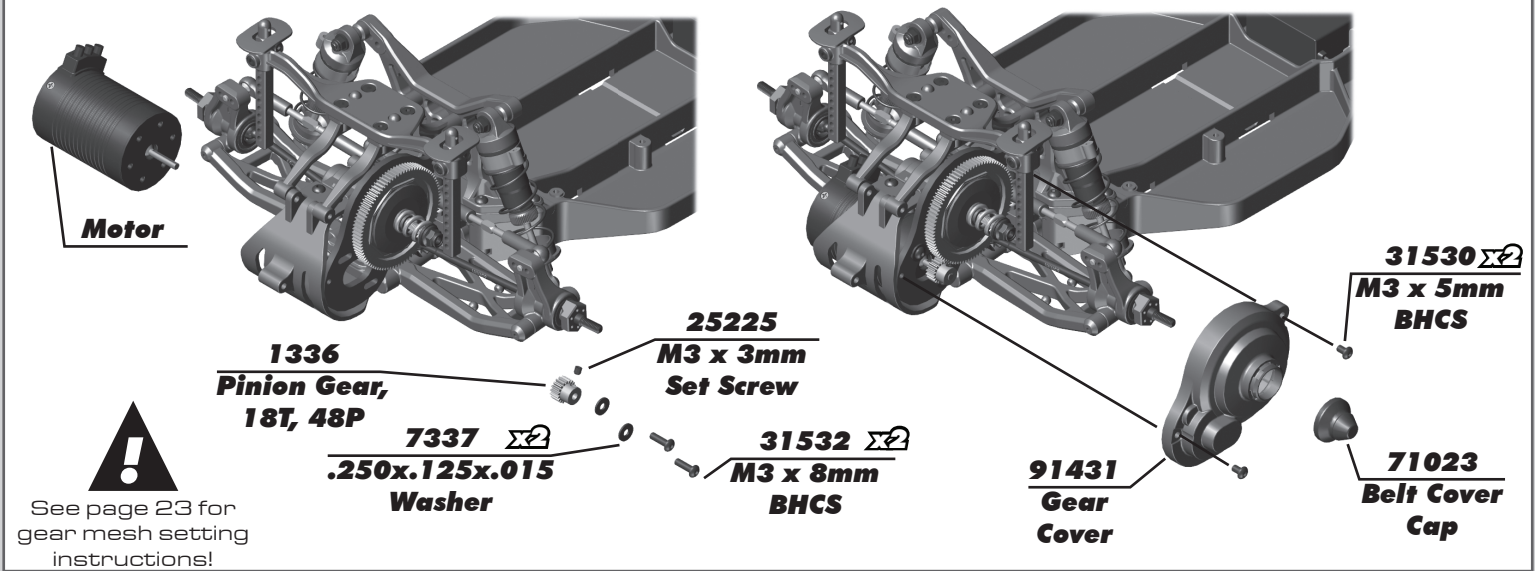

:: Electronics Build - Step 4

71023
Receiver Box
Grommet

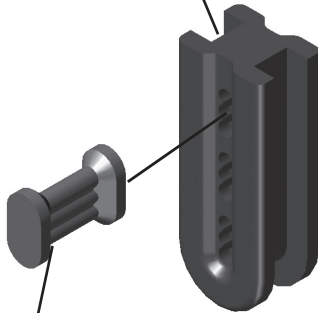

71023
Wire
Grommet
Plug



* Receiver grommet plug can be removed if you use a personal transponder!

!
* Install the ESC wires and the Servo wires into the wire grommet before installing the grommet into the receiver box!

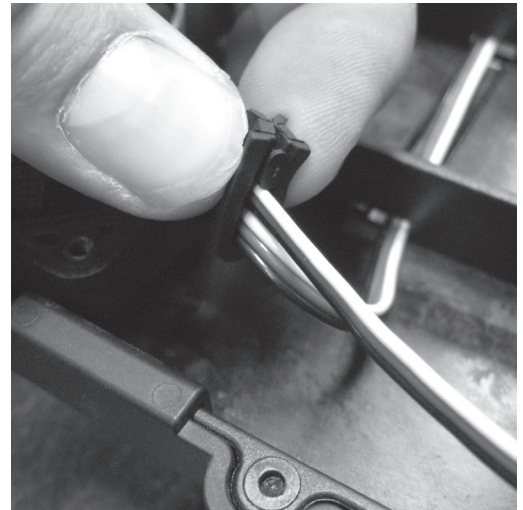

:: Electronics Build - Step 5

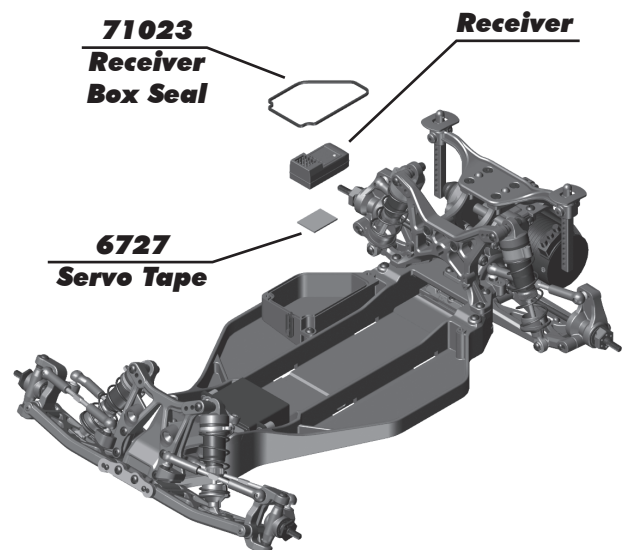
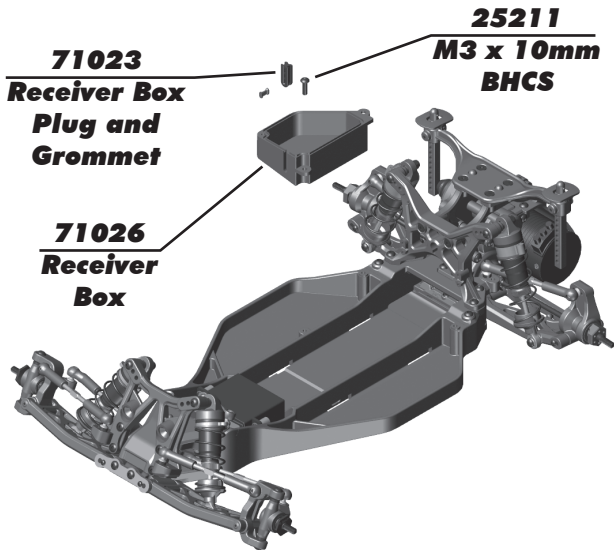

:: Electronics Build - Step 6

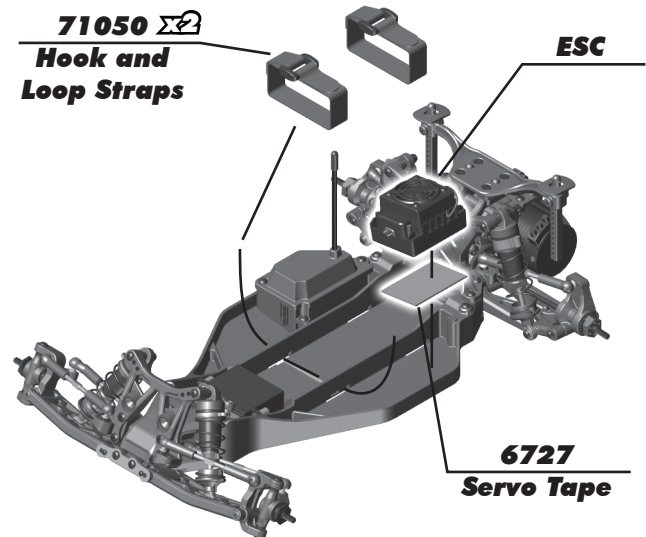
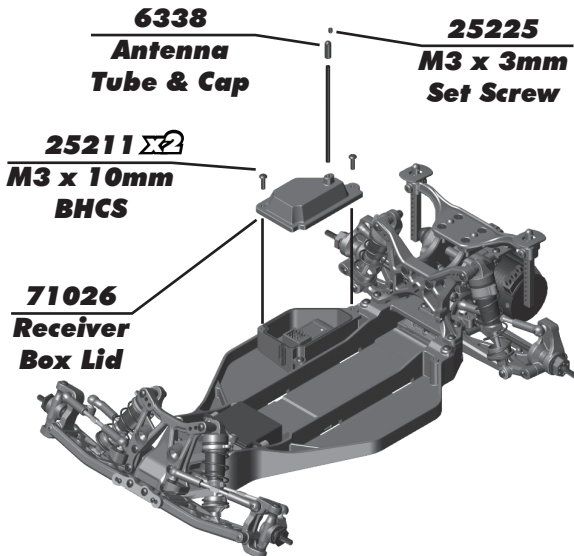

:: Electronics Build - Step 7

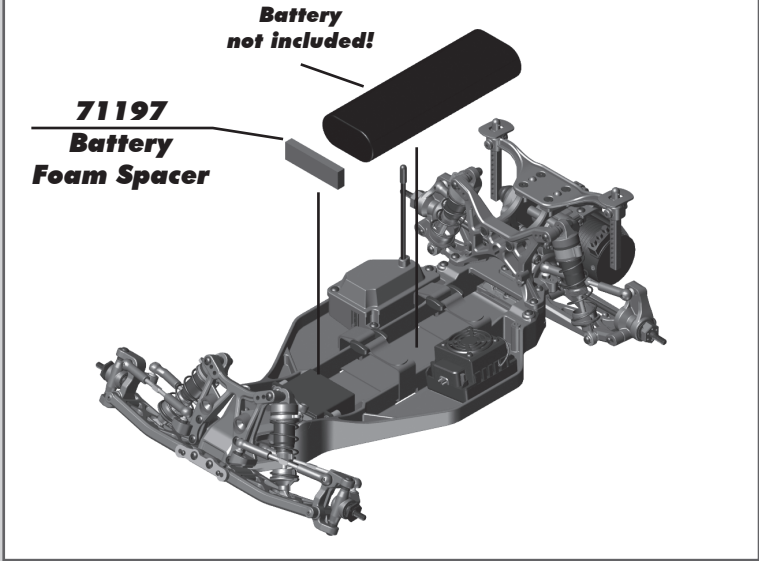

:: Bumpers Build - Step 1

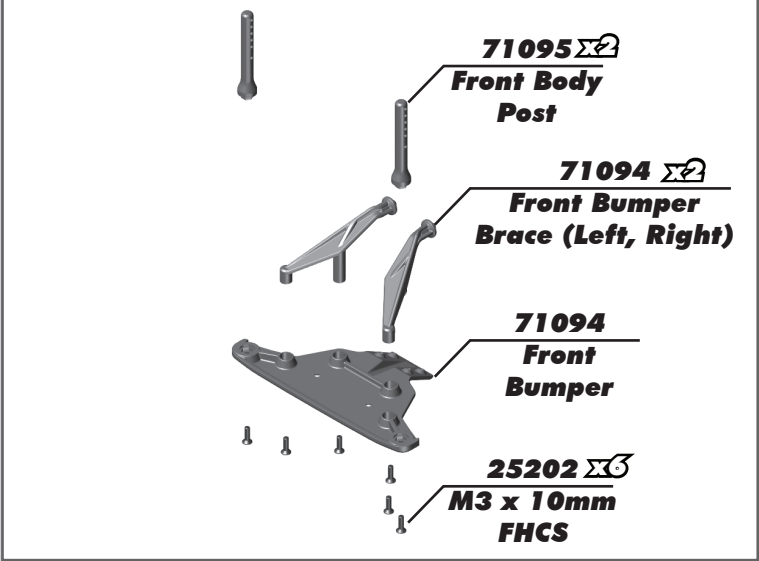

:: Bumpers Build - Step 2

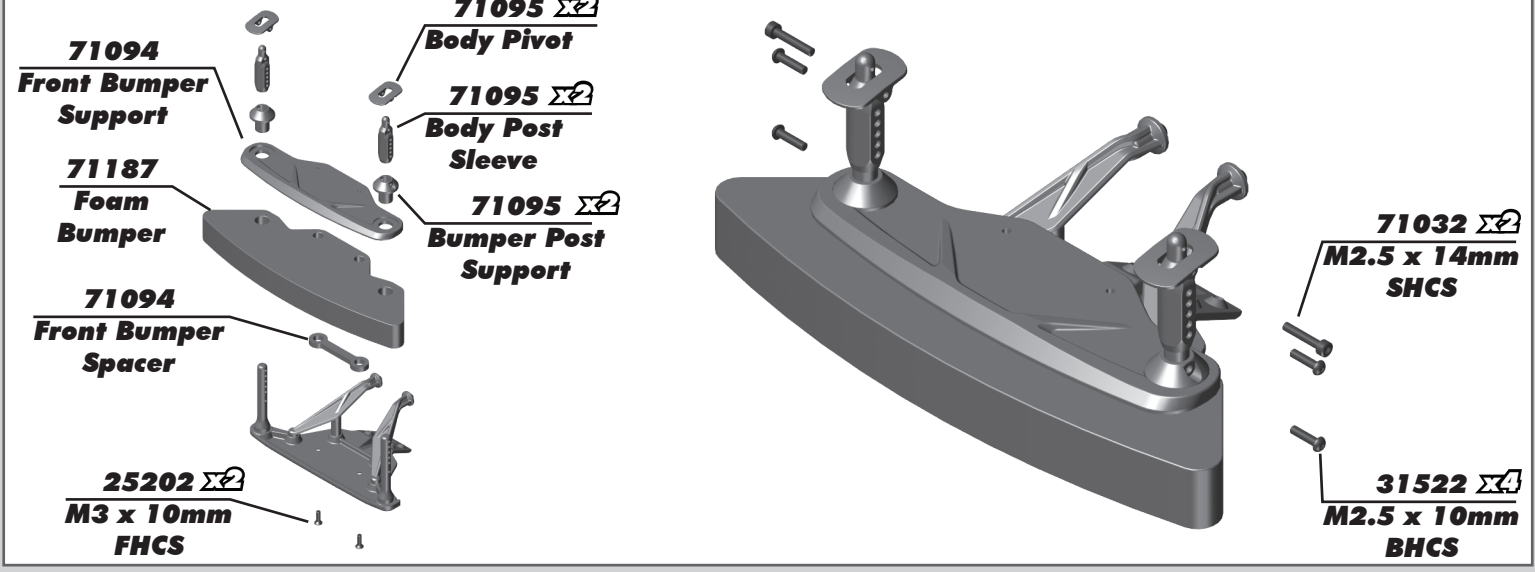

:: Bumpers Build - Step 3

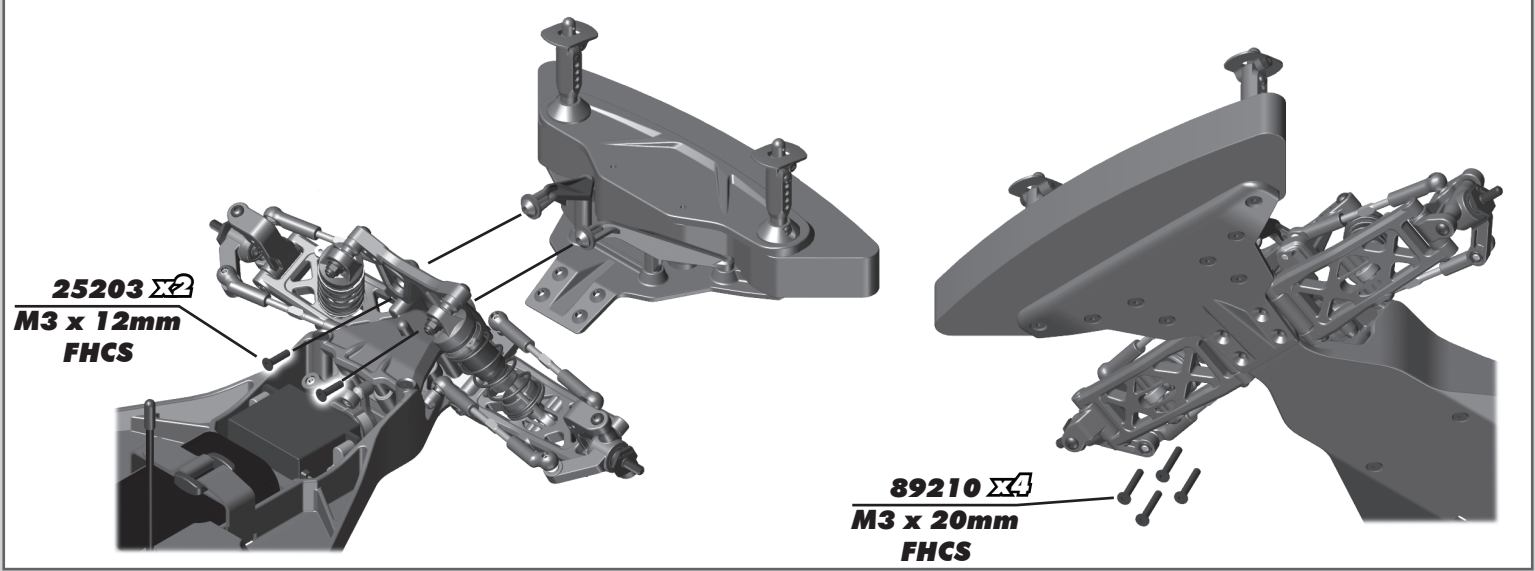

:: Bumpers Build - Step 4

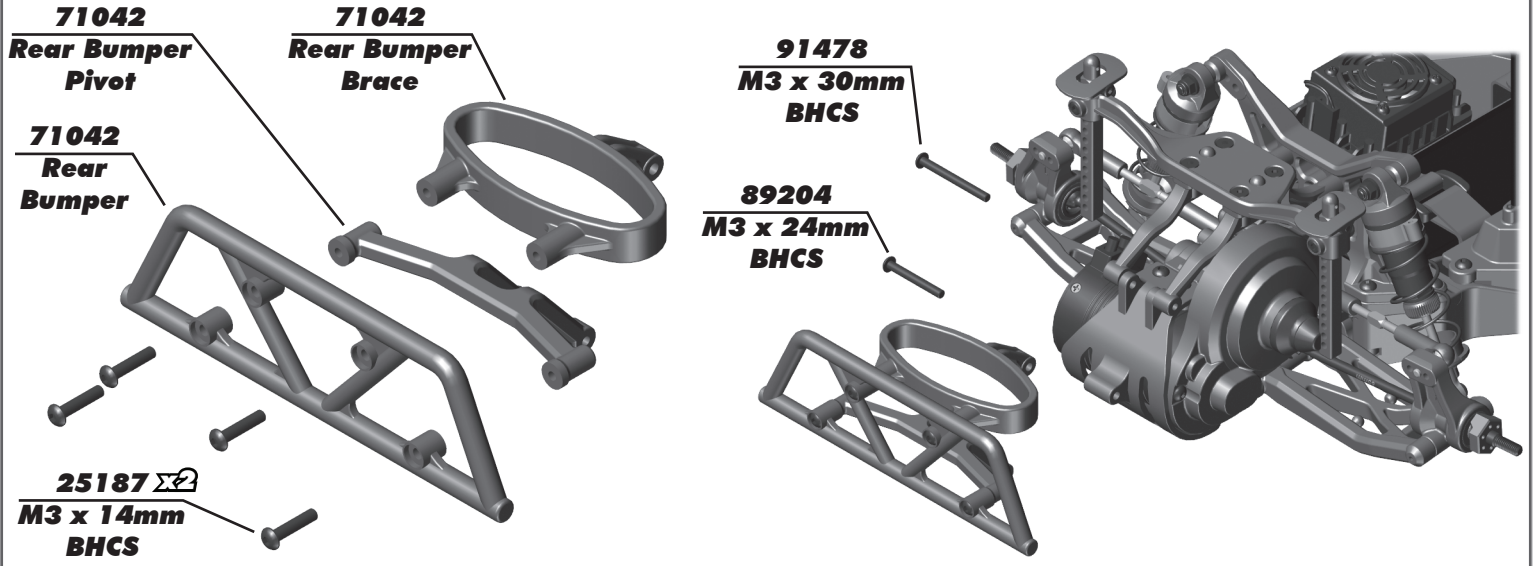

:: Tires and Body Build - Step 1

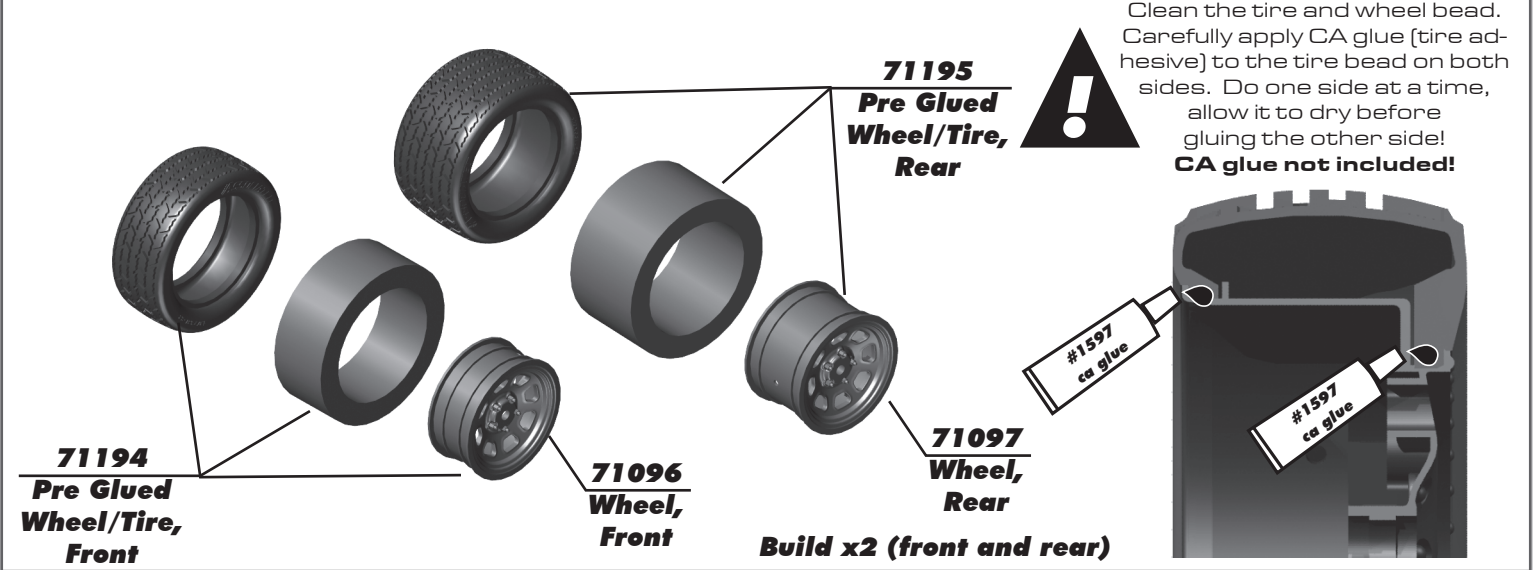

:: Tires and Body Build - Step 2

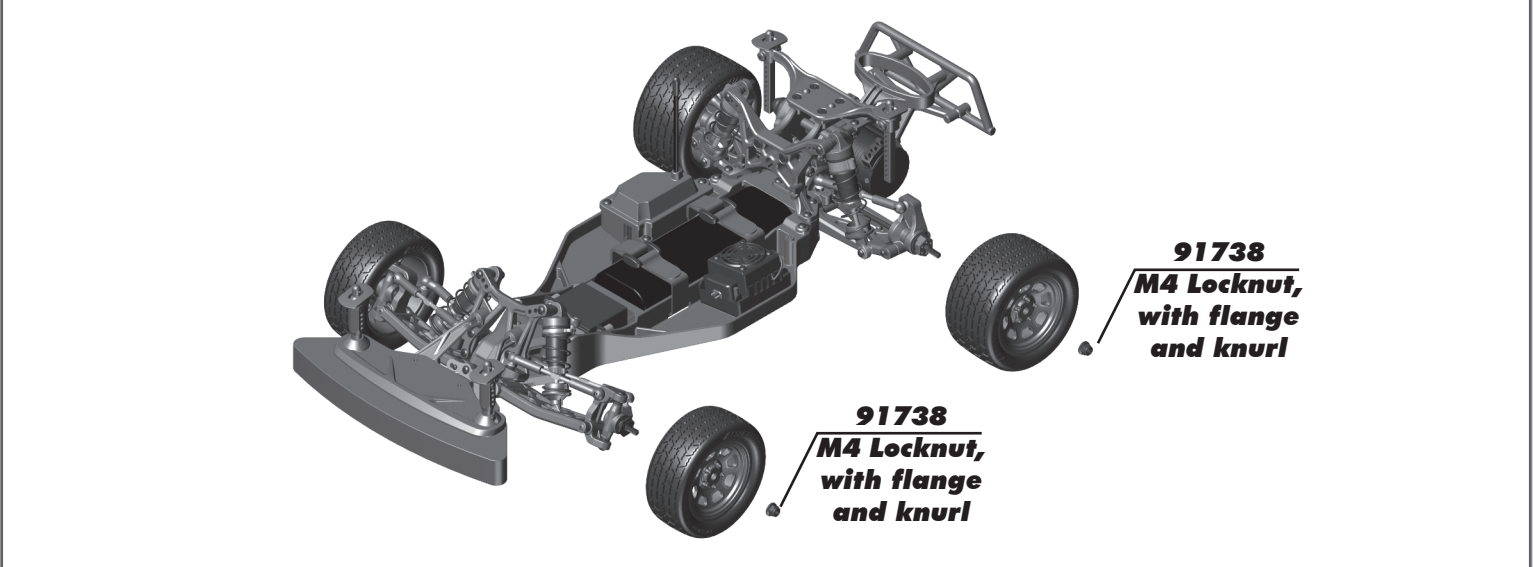

:: Tires and Body Build - Step 3

21173 x4
Small
Body Clips

71193
SR10 Street
Stock Body,
Painted

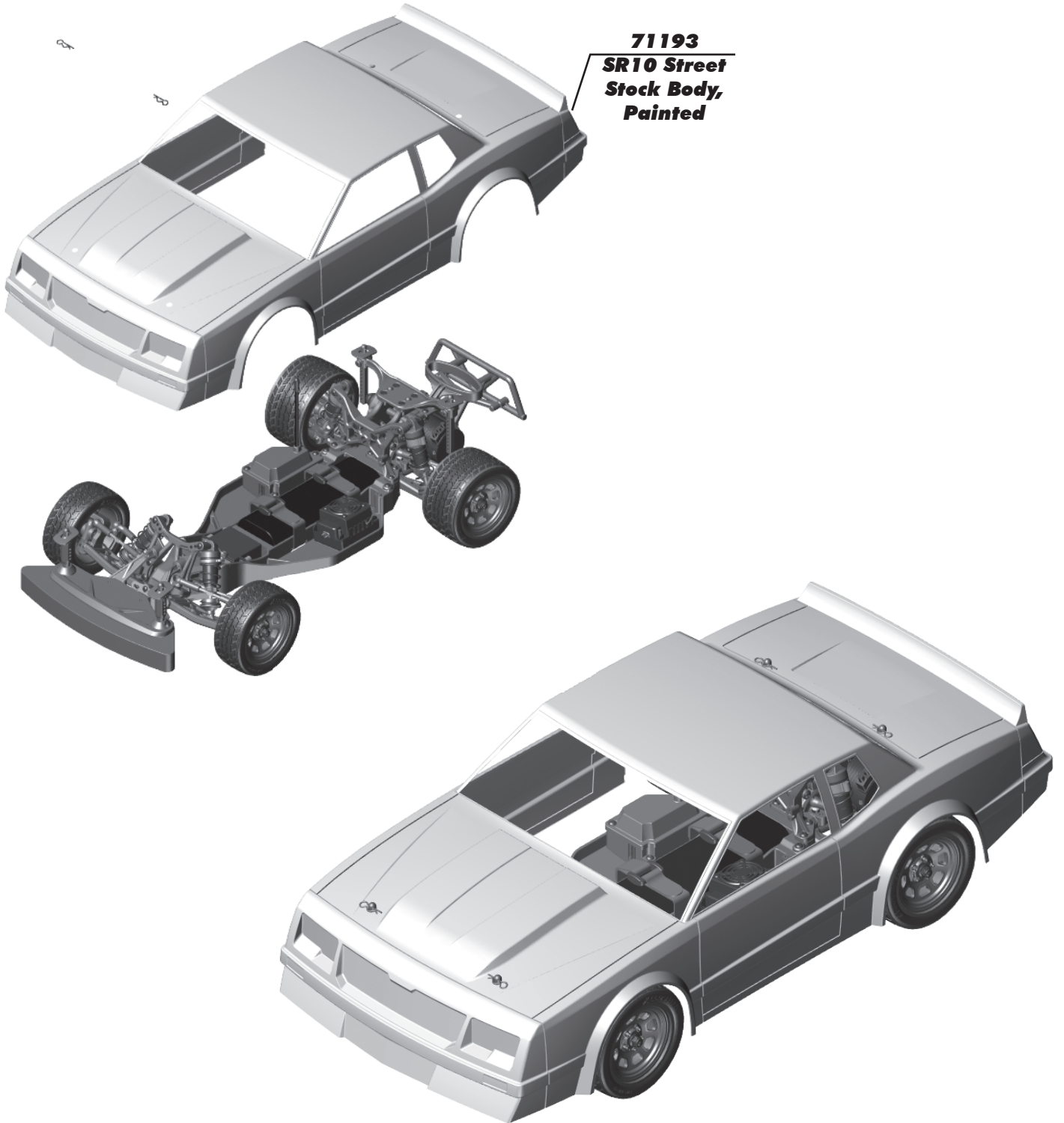

:: Tuning Tips

Tips for Beginners:

Before making any changes to the standard setup, make sure you can get around the track without crashing. Changes to your vehicle will not be beneficial if you can't stay on the track. Your goal is consistent laps.

Once you can get around the track consistently, start tuning your vehicle. Make only ONE adjustment at a time, testing it before making another change. If the result of your adjustment is a faster lap, mark the change on the included setup sheet (make additional copies of the sheet before writing on it). If your adjustment results in a slower lap, revert back to the previous setup and try another change.

Periodically check all moving suspension parts. Suspension components must be kept clean and move freely without binding to prevent poor and/or inconsistent handling.

Motor Gearing:

Proper motor gearing will result in maximum performance and run time while reducing the chance of overheating and premature motor failure. The gear ratio chart lists recommended **suggested starting gear ratios** for the most widely used motor types. Gear ratios will vary depending upon motor brand, wind, and electronic speed control. Consult your motor and electronic speed control manufacturers for more information. Team Associated is not responsible for motor damage due to improper gearing.

Gear Ratio Chart (Internal Gear Ratio 2.60:1)

Motor	Pinion	Spur	Final Drive Ratio
17.5 Reedy Sonic Brushless	*28	*75	6.96:1
13.5 Reedy Sonic Brushless	*26	*75	7.50:1
10.5 Reedy Sonic Brushless	*24	87	9.42:1
3300kV Brushless	18	87	12.57:1

*** Optional spur gear / pinion used**

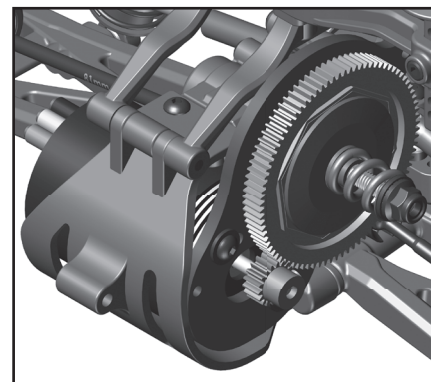

Set The Gear Mesh:

You should be able to rock the spur gear back and forth in the teeth of the pinion gear without making the pinion gear move. If the spur gear mesh is tight, then loosen the #31532 screws and move the motor away, then try again. A gear mesh that is too tight or too loose will reduce power and damage the gear teeth.

:: Tuning Tips (cont.)

Slipper Clutch:

The assembly instructions give you a base setting for your slipper clutch. Turn the nut on the shaft so that the end of the top shaft is flush with the nut. At the track, tighten or loosen the nut in 1/8 turn increments until you hear a faint slipping sound for 1-2 feet on takeoff. Another popular way to set the clutch is to hold both rear tires firmly in place and apply short bursts of throttle. If the clutch is properly set, the front tires should lift slightly up off the surface.

Ride Height:

Ride height is the distance from the ground to the bottom of the chassis. The standard front ride height setting is with the front arms level (referred to as "arms level") or 30mm.

Check the ride height by lifting up the entire car about 8-12 inches off the bench and drop it. After the suspension "settles" into place, measure ride height. Add or Remove pre-load spacers as necessary so that the left & right arms appear to be level.

The rear ride height setting you should use most often is with the outrdrive, driveshaft, and axles all on the same imaginary horizontal line (referred to as "bones level") or 28mm.

Check the ride height by lifting up the entire car about 8-12 inches off the bench and drop it. After the suspension "settles" into place, measure ride height. Add or Remove pre-load spacers as necessary so that the left & right driveshafts appear to be level.

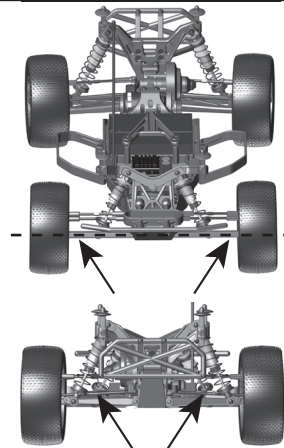

!
*Front arms inner and outer hinge pins should be in a imaginary horizontal line when ride height is set

!
*CVA bones should be in a straight line when ride height is set at "CVA bones level"

Front Camber:

Camber describes the angle at which the tire and wheel rides when looked at from the front. Negative camber means that the tire leans inward at the top. A good starting camber setting is -1°. Positive camber, where the top of the tire is leaning out, is not recommended. A camber gauge can be used to more accurately set camber.

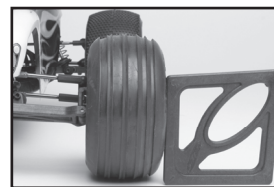

!
*Testing camber with camber gauge

Rear Camber:

Camber describes the angle at which the tire and wheel rides when looked at from the back. Negative camber means that the tire leans inward at the top. A good starting camber setting is -1°. Adding a small amount of positive camber, where the top of the tire is leaning out, will tend to improve straight-line acceleration on loose tracks. A camber gauge can be used to more accurately set camber.

Front Camber Links:

Changing the length of the camber link is considered a bigger step than adjusting the ball end height on the tower. Shortening the camber link (or lowering the ball end) will give the front end less roll and quicken steering response. Lengthening the camber link (or raising the ball end) will give the front more roll and slower steering response. Longer camber links are typically used on high grip tracks and shorter links tend to work better on medium-grip loose tracks.



!
*Raise or lower the ball end by adding or subtracting washers here

Rear Camber Link:

Changing the length of the camber link (see page 10) is considered a bigger step than adjusting the ball end height on the rear chassis brace. Shortening the camber link (or lowering the ball end) will give the rear end less roll and the car will tend to accelerate or "square up" better. Lengthening the camber link (or raising the ball end) will give the rear more roll and more cornering grip. Longer camber links are typically used on high grip tracks, while shorter links tend to work better on medium grip loose tracks. The kit setting is the best compromise of cornering grip and acceleration.

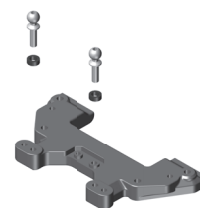

!
*Raise or lower the ball end by adding or subtracting washers here

Ackermann:

Ackermann is the angle difference between the front wheels when they are turned to steer the car. For minimal tire slip, it is standard for the inside wheel to steer to a greater angle than the outside wheel. The SR10 allows Ackermann adjustments by changing the washer thickness used behind the steering rack ballstuds. If corner entry steering is too aggressive, try increasing the Ackermann by removing shims from behind the steering rack ballstuds. Increasing the Ackermann will increase the angle difference of the front wheels when steered, resulting in a more stable car on corner entry.

:: Shocks

5407	Red O-Rings	8
6299	E-Clip	12
31327	FT VCS3 Shock Bottom Caps	2
71051	Shock Body 12 x 27.5mm	2
71054	Spring Clips and Retainer	1
71086	Internal Limiter, 6x6mm	1
71191	Shock Body 12 x 13mm	2
91444	Shock Accessories Set	1
91454	Shock Caps and Spring Cups	4 ea.
91469	Shock Pivot Ball and Rod End	4
91488	21 x 3mm Shock Shaft	2
91489	27.5 x 3MM Shock Shaft	2
91491	12MM V2 Shock Rebuild Kit	1

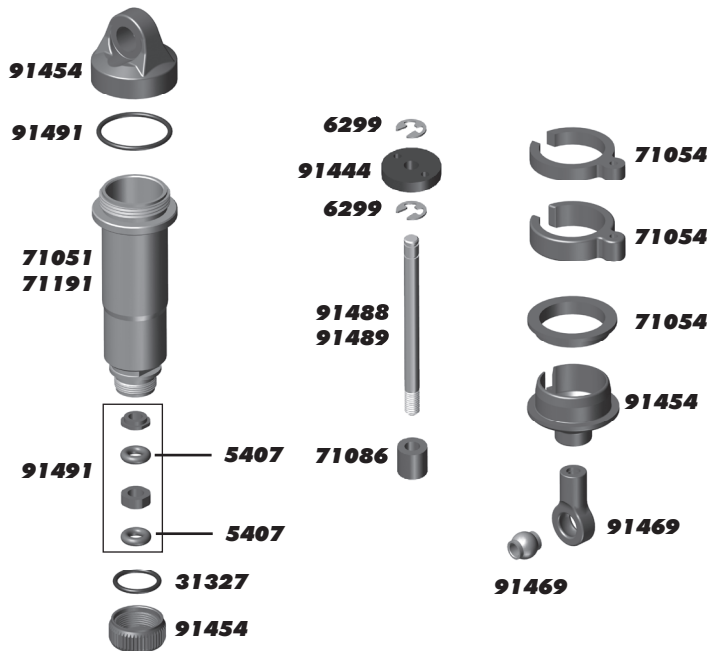

:: Shock Springs - Front

91830	12mm Spring (44mm) Green	3.10	2
91831	12mm Spring (44mm) White	3.40	2
91832	12mm Spring (44mm) Gray	3.60	2
91833	12mm Spring (44mm) Blue	3.90	2
91834	12mm Spring (44mm) Yellow	4.30	2
91835	12mm Spring (44mm) Red	4.60	2
91836	12mm Spring (44mm) Orange	5.10 - Kit	2



:: Shock Springs - Rear

91635	12mm Spring (54mm) Green	3.75	2
91636	12mm Spring (54mm) White	4.10 - Kit	2
91637	12mm Spring (54mm) Gray	4.45	2
91638	12mm Spring (54mm) Blue	4.80	2

:: Shock Fluid

5420	10 Weight Silicone Shock Fluid	2oz.
5421	20 Weight Silicone Shock Fluid	2oz.
5422	30 Weight Silicone Shock Fluid	2oz.
5423	40 Weight Silicone Shock Fluid	2oz.
5424	22.5 Weight Silicone Shock Fluid	2oz.
5425	80 Weight Silicone Shock Fluid	2oz.
5426	27.5 Weight Silicone Shock Fluid	2oz.
5427	15 Weight Silicone Shock Fluid	2oz.
5428	25 Weight Silicone Shock Fluid	2oz.
5429	35 Weight Silicone Shock Fluid	2oz.
5430	45 Weight Silicone Shock Fluid	2oz.
5431	55 Weight Silicone Shock Fluid	2oz.
5432	32.5 Weight Silicone Shock Fluid	2oz.
5433	37.5 Weight Silicone Shock Fluid	2oz.
5434	42.5 Weight Silicone Shock Fluid	2oz.
5435	50 Weight Silicone Shock Fluid	2oz.
5436	60 Weight Silicone Shock Fluid	2oz.
5437	70 Weight Silicone Shock Fluid	2oz.
5438	47.5 Weight Silicone Shock Fluid	2oz.

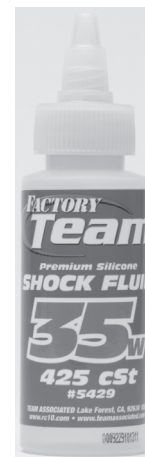

:: Gear Differential

31350	M2.5 x 10 FHCS	6
42025	Outdrive Pins	2
91463	Gear Diff Rebuild	1
91465	Gear Diff Outdrives, B5	2
91466	Diff and Idler Gears	1

:: Differential Fluids

5444	Silicone Diff Fluid 4,000CST	1
5446	Silicone Diff Fluid 6,000CST	1
5447	Silicone Diff Fluid 15,000CST	1
5448	Silicone Diff Fluid 80,000CST	1
5451	Silicone Diff Fluid 2,000CST	1
5452	Silicone Diff Fluid 3,000CST	1
5453	Silicone Diff Fluid 5,000CST	1
5454	Silicone Diff Fluid 7,000CST	1
5455	Silicone Diff Fluid 10,000CST	1
5456	Silicone Diff Fluid 20,000CST	1
5457	Silicone Diff Fluid 30,000CST	1
5458	Silicone Diff Fluid 60,000CST	1
5459	Silicone Diff Fluid 100,000CST	1
5461	Silicone Diff Fluid 200,000CST	1
5463	Silicone Diff Fluid 500,000CST	1
5464	Silicone Diff Fluid 1,000,000CST	1

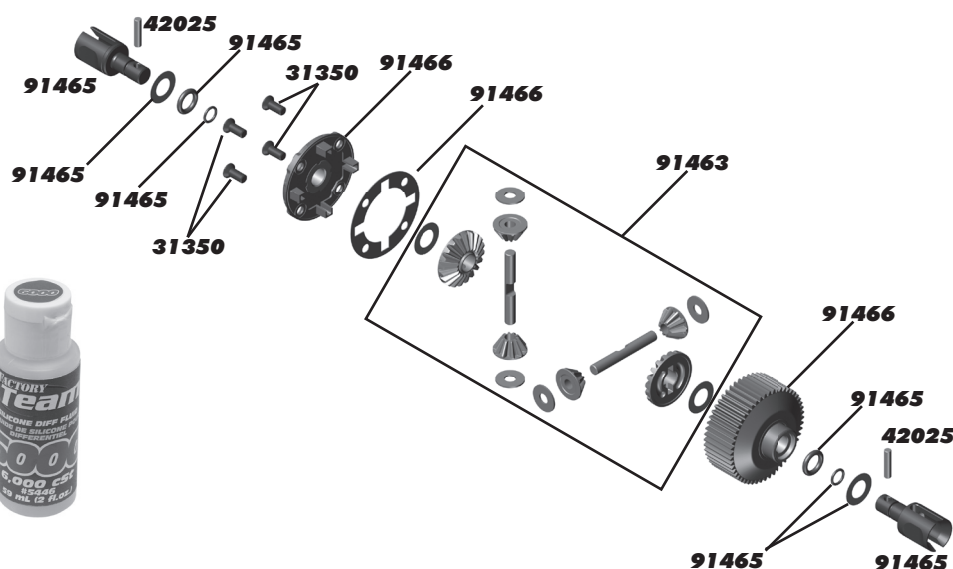

:: Transmission

7337	.250x.125x.015" Washer	10
25202	M3 x 10mm FHCS	10
25203	M3 x 12mm FHCS	10
25211	M3 x 10mm BHCS	10
25237	Bearing, 5 x 10 x 4	2
31532	M3 x 8mm BHCS	10
89203	M3 x 16mm BHC	10
91132	4x4 Idler Gear Shaft	1
91428	Motor Plate (Blue), B5	1
91430	Gearbox	Pr.
91431	Gear Cover / Motor Guard	1
91466	Diff and Idler Gear	1
91563	FT Bearing, 10 x 15 x 4	4
91606	Aluminum Top Shaft V2	1

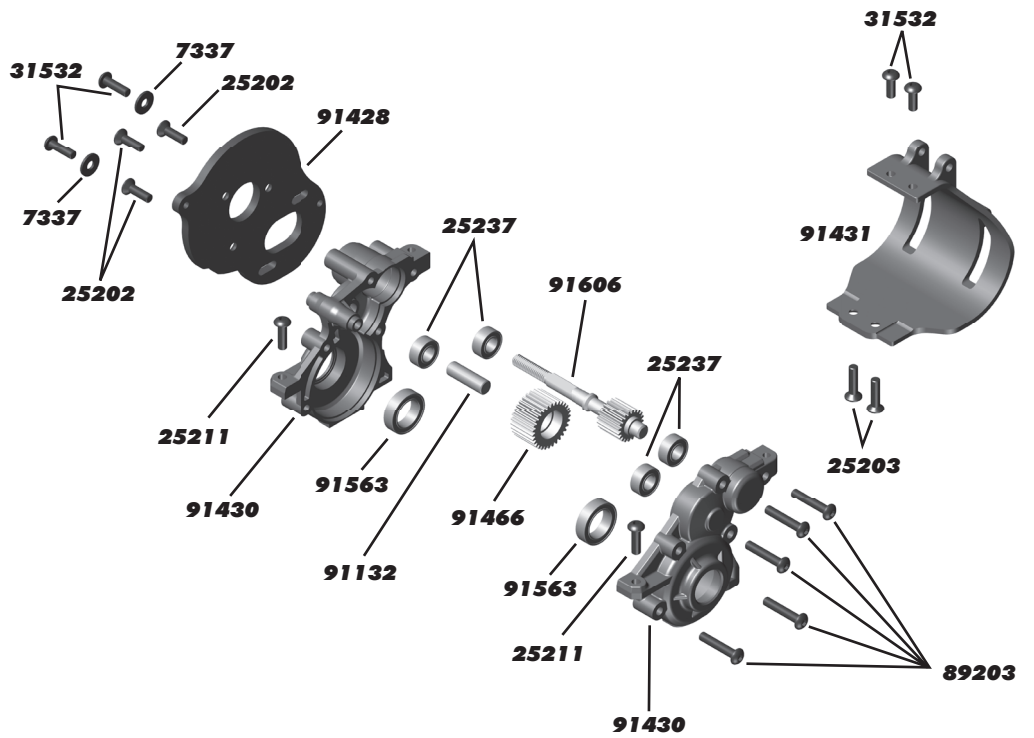

:: Slipper Clutch

7485	FT V2 Slipper Hubs	2
9611	Slipper Pad	2
9648	69T 48P Spur Gear	1
9649	72T 48P Spur Gear	1
9650	75T 48P Spur Gear	1
9651	81T 48P Spur Gear	1
9652	78T 48P Spur Gear	1
9653	84T 48P Spur Gear	1
9654	87T 48P Spur Gear (Kit)	1
9739	Slipper Spring	1
31530	M3 x 5 BHCS	10
71023	Belt Cover Cap	2
91423	Slipper Spring Adapter	2
91431	Gear Cover (Black)	1
91738	M4 Serrated Nuts, Black	8



:: Pinion Gears

1335	17T 48P Aluminum Pinion Gear	1	1349	31T 48P Aluminum Pinion Gear	1
1336	18T 48P Aluminum Pinion Gear	1	1350	32T 48P Aluminum Pinion Gear	1
1337	19T 48P Aluminum Pinion Gear	1	1351	33T 48P Aluminum Pinion Gear	1
1338	20T 48P Aluminum Pinion Gear	1	1352	34T 48P Aluminum Pinion Gear	1
1339	21T 48P Aluminum Pinion Gear	1	25225	M3 x 3mm Set Screw	20
1340	22T 48P Aluminum Pinion Gear	1			
1341	23T 48P Aluminum Pinion Gear	1			
1342	24T 48P Aluminum Pinion Gear	1			
1343	25T 48P Aluminum Pinion Gear	1			
1344	26T 48P Aluminum Pinion Gear	1			
1345	27T 48P Aluminum Pinion Gear	1			
1346	28T 48P Aluminum Pinion Gear	1			
1347	29T 48P Aluminum Pinion Gear	1			
1348	30T 48P Aluminum Pinion Gear	1			

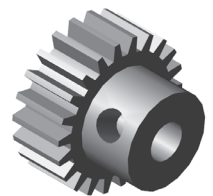

:: Optional Ball Differential

6573	Diff Thrust Washer & Bolt	2
6574	Precision Diff Thrust Balls, 5/64"	6
6575	Locking T-Nut, Diff Thrust Bolt, & Cover	1
6581	3/32" Carbide Diff Balls	14
6582	Diff Thrust Spring	1
7666	Diff Drive Rings, 2.60:1	2
7677	Ball Diff Rebuild Kit	1
8680	Bearing, 5 x 8mm	4
91419	Diff Gear, B5	1
91420	Ball Diff Outdrive, B5	1 ea.

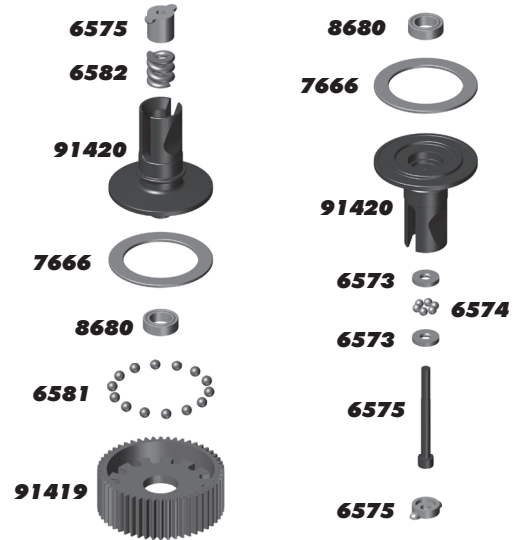

:: Turnbuckles and Servo Mounts

7337	.250 x .125 x .015" Washer	4
25201	M3 x 8MM FHCS	10
31532	M3 x 8 BHCS	10
71047	Servo Saver	1
91047	Heavy-duty Ballstud, 6mm	10
91391	Servo Mount and Steering Rack	1
91469	Ball Cups and Steering Link Set	1
91723	3x48mm Turnbuckles	2

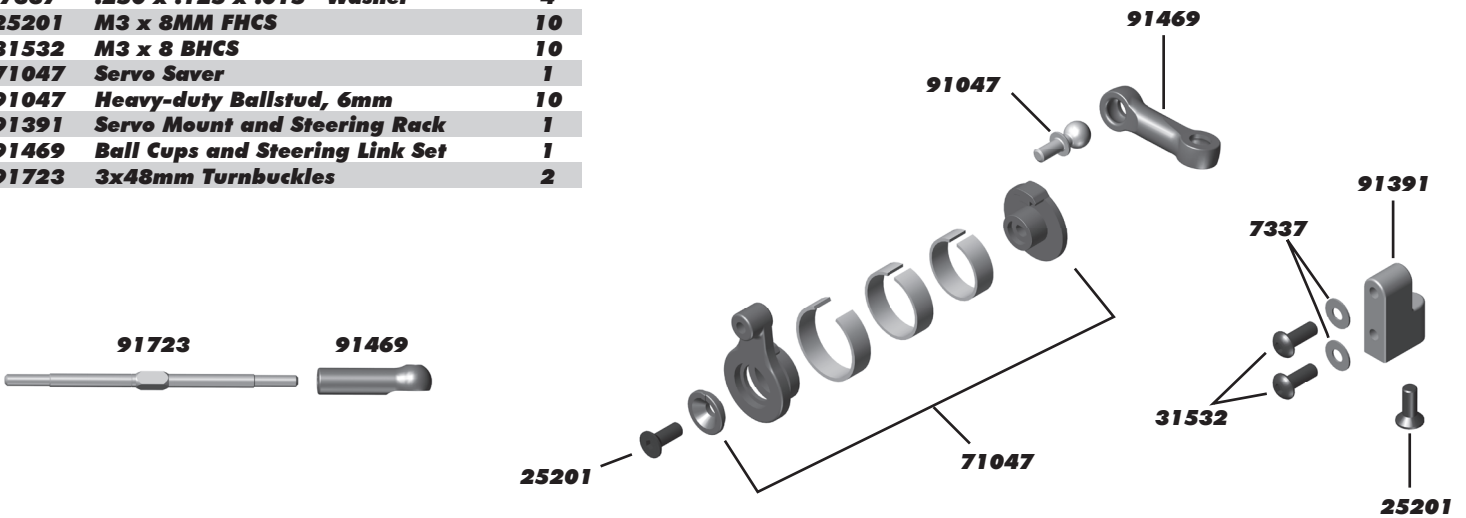

:: Front Bulkhead / Steering

25189	M3 x 22mm BHCS	10
25202	M3 x 10mm FHCS	10
89202	M3 x 12mm BHCS	10
91047	Heavy-duty Ballstud, 6mm	10
91358	Top Plate	1
91391	Steering Set, B5	1
91475	3x7x3 Ball Bearing	8

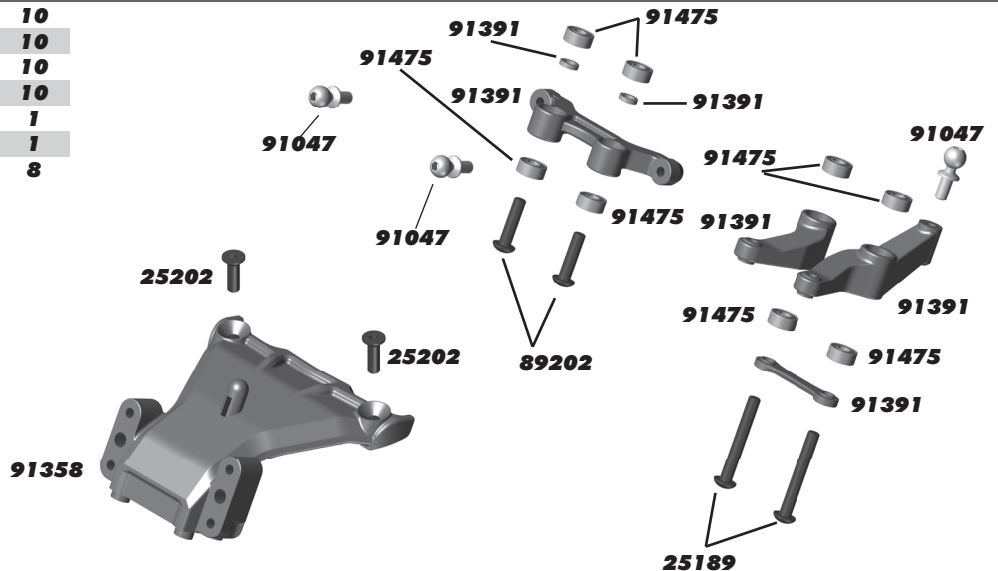

:: Front Arm

25189	M3 x 22mm BHCS	10
25215	M3 Locknut, Black	20
25237	Bearing, 5 x 10 x 4	2
31510	M2 x 4mm BHCS	10
31530	M3 x 5mm BHCS	10
71068	Suspension Arm Set	1
71127	Front Axle	2
89202	M3 x 12mm BHCS	10
91047	Heavy-duty Ballstud, 6mm	10
91048	Heavy-duty Ballstud, 8mm	10
91394	Hinge Pin Set, B5	1
91402	Caster Block Bushing, B5	4
91417	Caster and Steering Blocks	Pr.
91738	M4 Serrated Nuts, Black	8

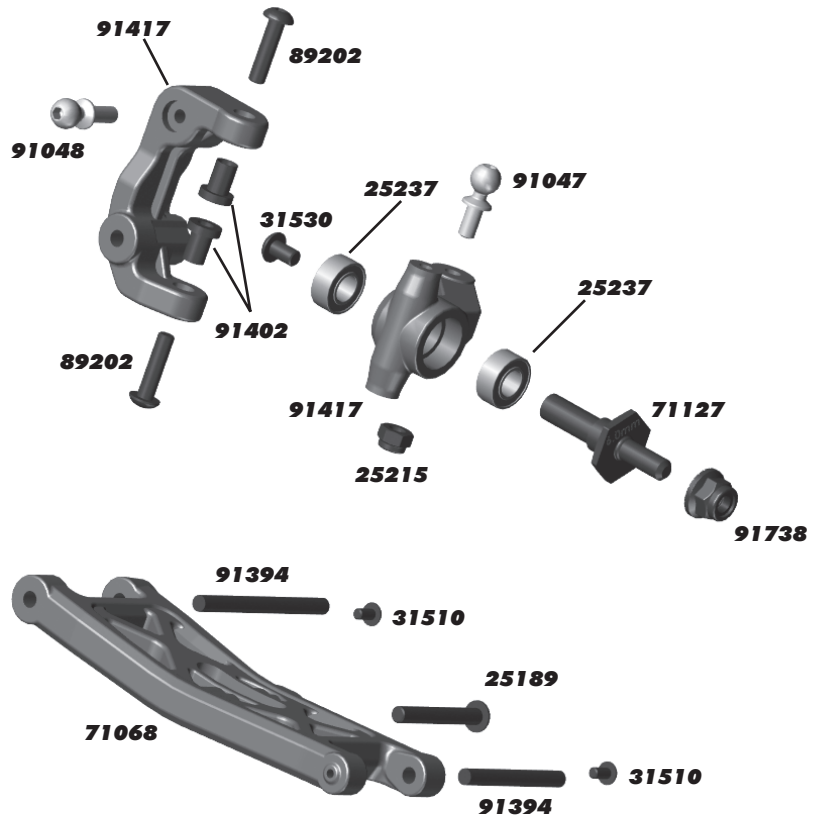

:: Rear Arm

31510	M2 x 4mm BHCS	10
71019	RC10T5M HD CVA Axle	2
71068	Suspension Arm Set	1
89202	M3 x 12mm BHCS	10
91048	Heavy-duty Ballstud, 8mm	10
91394	Hinge Pin Set, B5	1
91418	Rear Hubs and Wheel Hexes	Pr.
91436	CVA/Wheel Hex Pin, B5	4
91438	CVA Rebuild Kit, B5	1
91439	Rear CVA Bones, 65mm	2
91562	6x13x5 Ball Bearing	2
91563	10x15x4 Ball Bearing	2
91738	M4 Serrated Nuts, Black	8

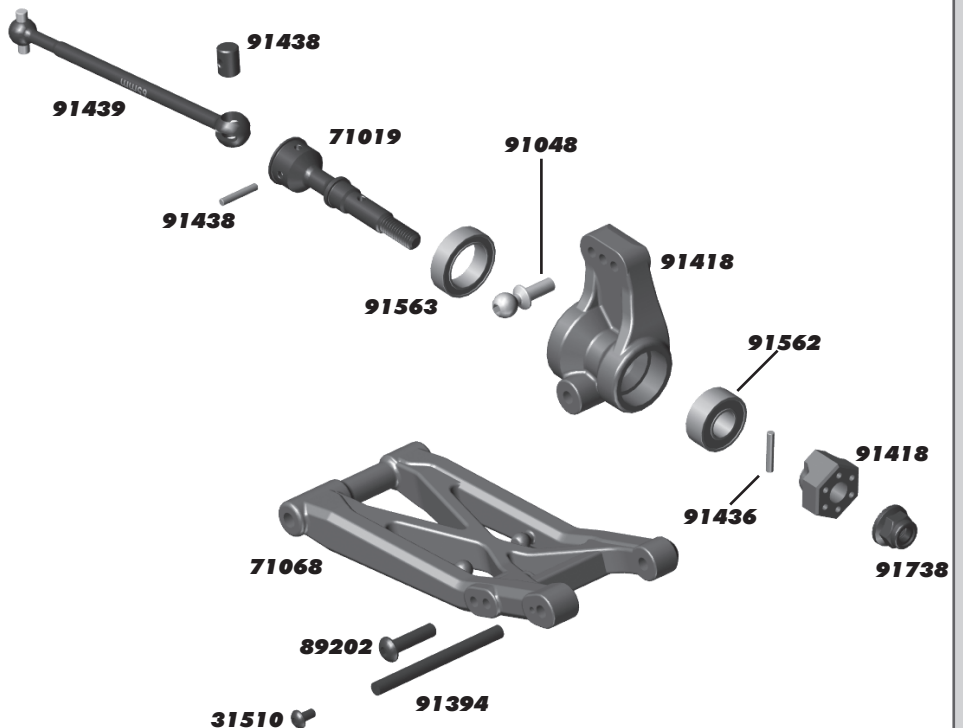

:: Battery Strap

71050	Hook and Loop Straps	2
71197	SR10 Foam Battery Spacer	1

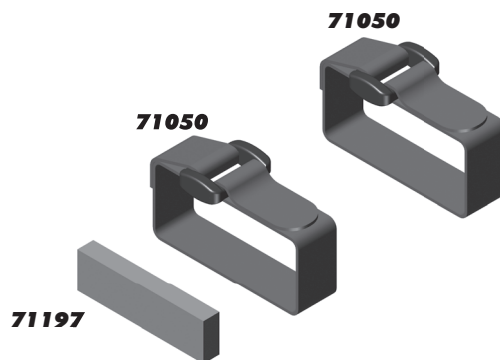

:: Front Bumper

25202	M3 x 10mm FHCS	10
25203	M3 x 12mm FHCS	10
31522	M2.5 x 10mm BHCS	10
71032	M2.5 x 14mm SHCS	10
71094	SR10 Front Bumper Set	1
71095	SR10 Body Post Set	1
71187	SR10 Foam Bumper	1
89210	M3 x 20mm FHCS	10

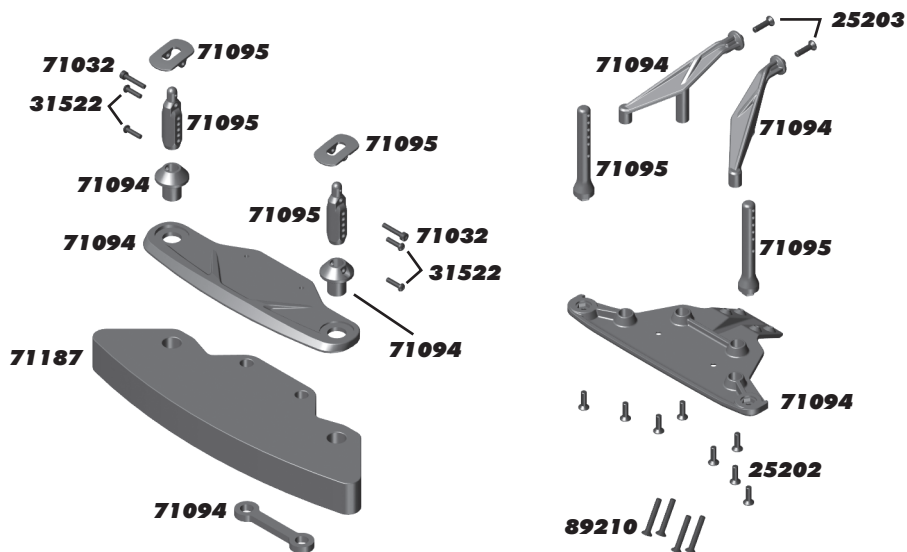

:: Rear Bumper

25187	M3 x 14mm BHCS	10
71042	Rear Bumper Set	1
89204	M3 x 24mm BHCS	10

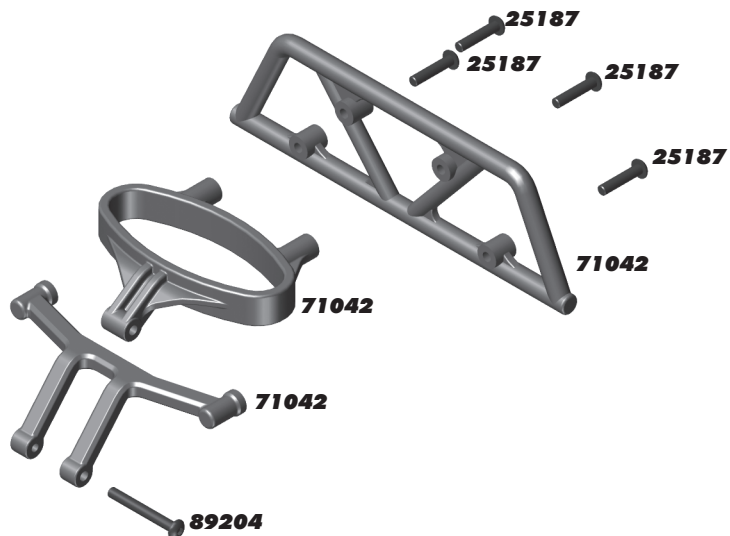

:: Front Shock Tower

25612	M3 Locknut, with flange	20
31383	Ballstud Washer, 5.5 x 2mm, Blue Aluminum	10
71032	M2.5 x 14MM SHCS	10
71066	Body Posts and Body Mount	1
71093	SR10 Shock Tower Set	1
89202	M3 x 12mm BHCS	10
89205	M3 x 26mm BHCS	10
91049	Heavy-Duty Ballstud, 10mm	10
91444	Shock Rebuild Kit	1
91477	M3 Nut, Black	6

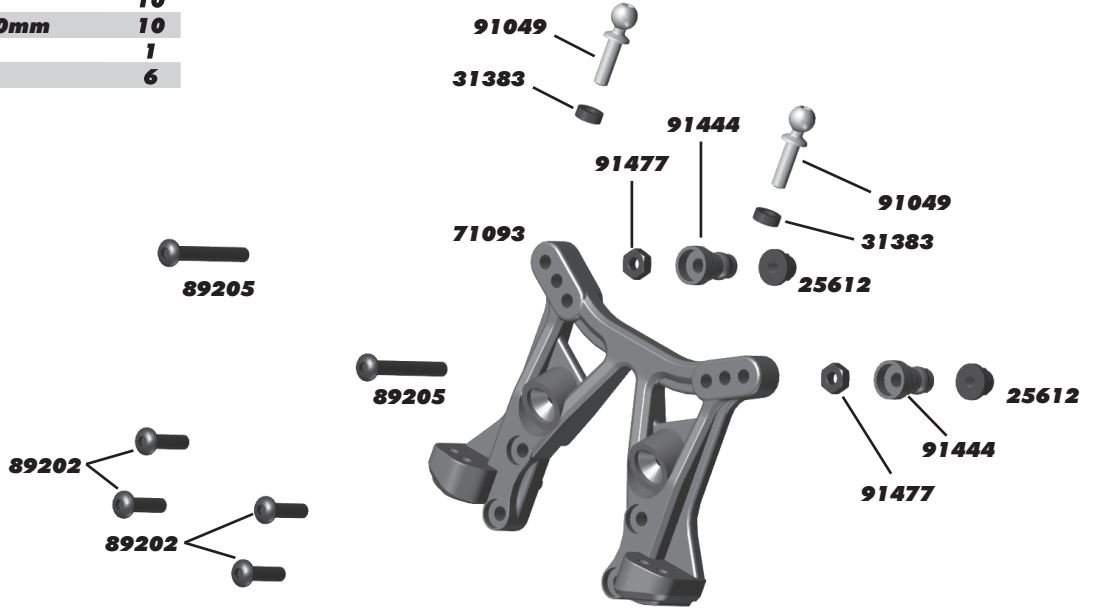

:: Rear Shock Tower

21173	Small Body Clips	12
25187	M3 x 14mm BHCS	10
25202	M3 x 10mm FHCS	10
25204	M3 x 16mm FHCS	10
25211	M3 x 10mm BHCS	10
25612	M3 Locknut, with Flange	10
71032	M2.5 x 14MM SHCS	10
71038	Rear Body Mounts	1
71066	Body Posts and Body Mount	1
71093	SR10 Shock Tower Set	1
89204	M3 x 24mm BHCS	10
91444	Shock Bushing Composite	4
91477	M3 Nut, Black	6
91478	M3 x 30mm BHCS	10

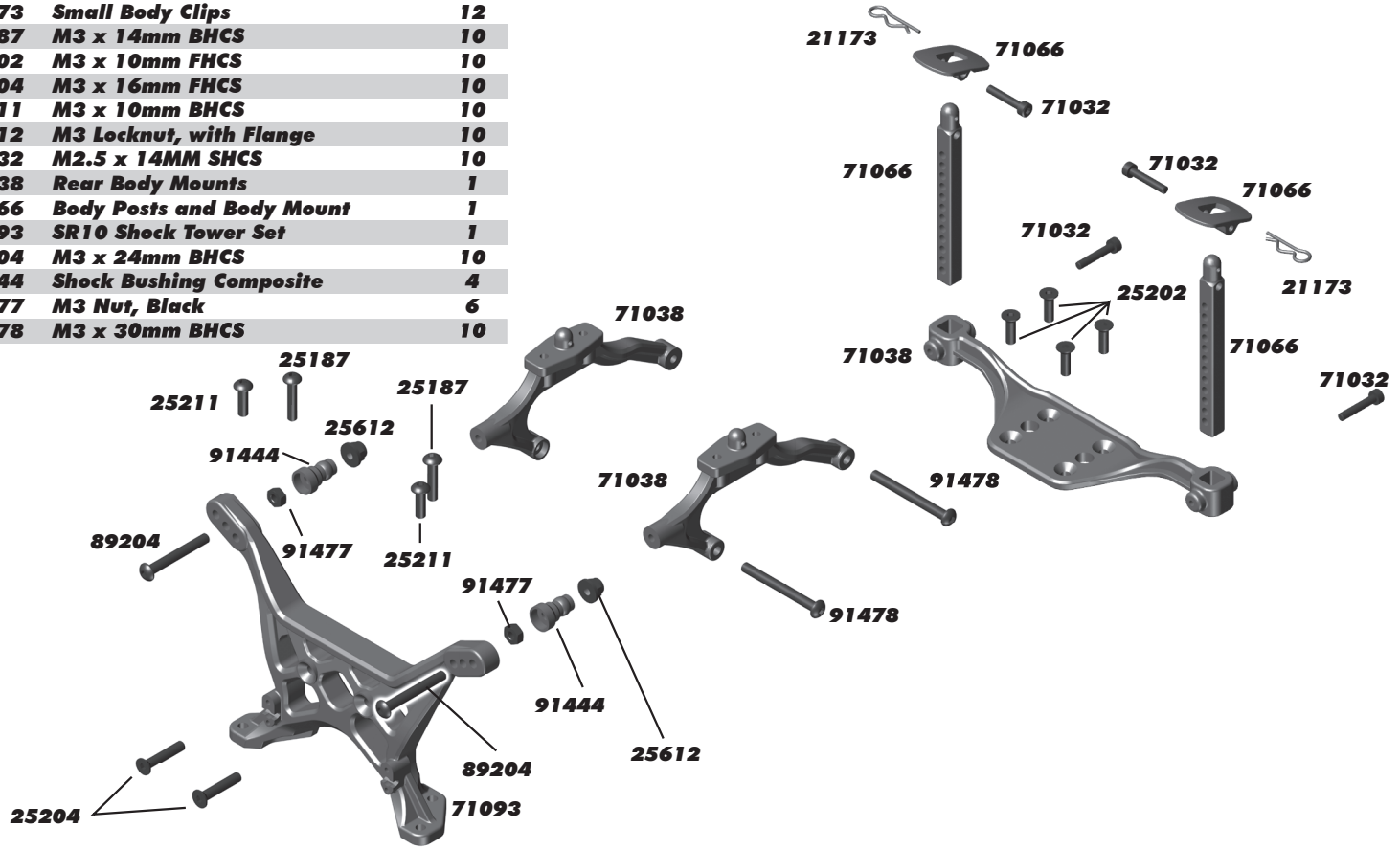

:: Chassis

6338	Antenna Tube & Cap (black)	1
25187	M3 x 14mm BHCS	10
25203	M3 x 12mm FHCS	10
25211	M3 x 10mm BHCS	10
25225	M3 x 3mm Set Screw	10
31383	Ballstud Washer, 5.5 x 2mm, Blue Aluminum	10
31509	M2 x 3mm BHCS	10
31521	M2.5 x 8mm BHCS	10
71023	Receiver Box Seals	1
71026	Receiver Box	1
71049	Hinge Pin Brace	1
71092	SR10 Chassis	1
89208	M3 x 14mm FHCS	10
91049	Heavy-Duty Ballstud, 10mm	10
91358	Chassis Brace Set	1
91359	Arm Mounts, Braces, and Bulkhead	1
91394	Hinge Pin Set, B5	1

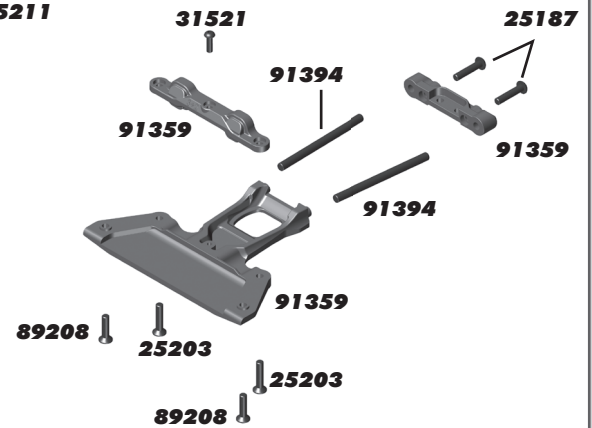
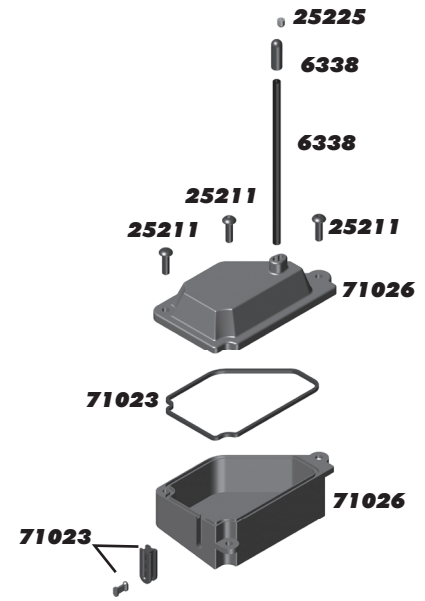
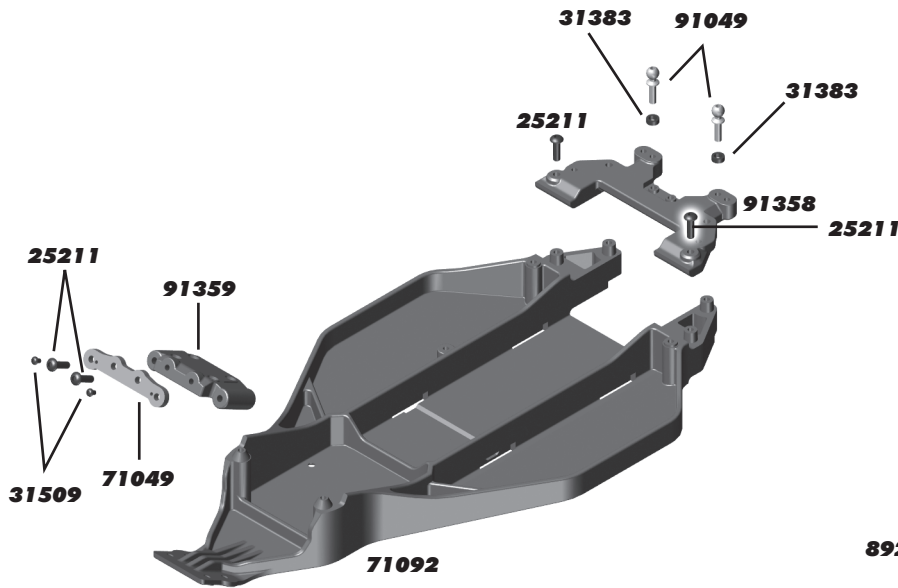

:: Wheels / Tires

71096	SR10 Front Wheels, Black	2
71097	SR10 Rear Wheels, Black	2
71194	SR10 Front Wheels w/Street Stock Tires, Mounted	2
71195	SR10 Rear Wheels w/Street Stock Tires, Mounted	2

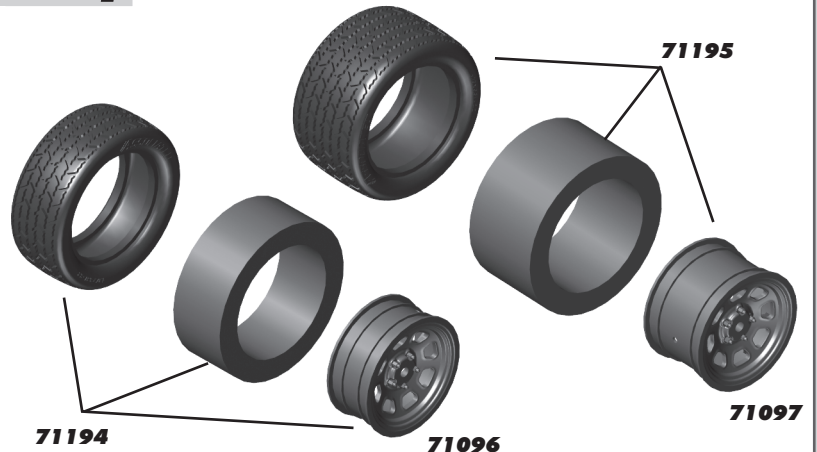

:: Body and Decals

21173	Body Clips	10
71192	SR10 Street Stock Body, Clear	1
71193	SR10 Street Stock Body, Painted	1

:: Factory Team and Option Parts

1409	FT Ti Turnbuckle, 1"/25.5mm (sway bar) (blue)	Pr.
1736	FT Blue Body Clip, short	6
7495	Vented V2 Slipper Hubs	2
25392	FT Locknuts, 3mm Aluminum, Blue	10
27128	Servo Washers, Aluminum, Black	4
31381	FT Ballstud Washer, Aluminum (0.5mm)	10
31382	FT Ballstud Washer, Aluminum (1.0mm)	10
31383	FT Ballstud Washer, Aluminum (2.0mm)	10
71014	Clamping Wheel Hex (8.5mm)	2
71034	FT Clamping Wheel Hexes, 6.0 mm	2
91387	FT Aluminum Arm Mount (D)	1
91389	Arm Mount Insert (D), B5	1
91392	Aluminum Steering Set, B5	1
91464	FT Aluminum Gear Diff Cover	1
91492	12mm V2 Bleeder Gasket/Screw	1
91493	FT Low Friction X-Rings	8
91495	12mm V2 X-Ring Rebuild Kit (4 clear x rings, 2 spacers, 4 hat bushings)	1
91548	RC10B5 Aluminum Rear Hubs (Blue)	Pr.
91550	RC10B5 Rear Hub Bearing Inserts	2 ea.
91553	Factory Team Bearing Kit, B5, B5M, T5M, SC5M	1
91560	5x10x4mm Factory Team Bearings	4
91562	6x13x5mm Factory Team Bearings	4
91563	10x15x4mm Factory Team Bearings	4
91576	FT 12 x 23 Shock Body (V2), threaded	2
91577	FT 12 x 27.5 Shock Body (V2), threaded	2
91609	Clamping Wheel Hex, (5.0mm offset)	2
91610	Clamping Wheel Hex, (7.0mm offset)	2
91617	3x23 mm Shock Shaft V2, TiN	2
91618	FT 3x23 mm Shock Shaft V2, chrome	2
91619	3 x 27.5 Shock Shafts (V2), TiN	2
91620	FT 3 x 27.5 Shock Shafts (V2), Chrome	2
91626	FT 12mm Pistons (V2), 2 x 1.6, flat	4
91627	FT 12mm Pistons V2, 2 x 1.7, flat	4
91628	FT 12mm Pistons (V2), 3 x 1.4, flat	4
91630	FT 12mm Pistons (V2), Blank, flat	4
91631	FT 12mm Pistons (V2), 3 x 1.4, tapered	4
91633	FT 12mm Pistons (V2), Blank, tapered	4

:: Reedy Speed Controls

27002	Blackbox 800Z 2S Zero-Timing Competition ESC	1
27004	Blackbox 510R Competition ESC	1
27005	Blackbox 510R Competition ESC w/PROgrammer2	1
27007	Blackbox 850R Competition 1/8 ESC	1
27008	Blackbox 850R Competition 1/8 ESC w/Programmer	1
27024	Blackbox Pro Capacitor Unit	1
27027	Blackbox PROgrammer2	1
27028	Blackbox 30x30x7mm Fan w/screws	1
27029	Blackbox Pro Modified Capacitor Unit	1
27030	Blackbox ESC/Programmer2 Connection Wire	1
27031	Blackbox 510R 30x30x10mm Fan w/screws	1
27032	Blackbox 850R 30x30x10mm Fan w/screws	1
27033	Blackbox 1000Z+ Pro Competition ESC	1
27036	Reedy CF Fan Guard (30x30mm)	1
29184	SC800-BL/SC1000-BL/SC1000-DB/SC600-BL Switch	1
29185	SC600-BL Brushless ESC	1
29186	SC600-BL Fan	1
29193	SC550 Brushed ESC	1
29194	SC550 Bridge Plug	1

:: Lubes & Adhesives / Misc.

1105	FT Green Slime Shock Lube	1
1596	FT Locking Adhesive	1
1597	FT Tire Adhesive	1
6588	Black Grease - 4cc	1
6591	Diff Lube - 4cc	1
6636	Silicone Grease - 4cc	1
6727	Servo Tape	2

1596

**:: Reedy Batteries and Chargers**

302	AA Alkaline 1.5V (4)	1
751	Wolfpack LiPo 3300mAh 30C 7.4V w/T-Plug	1
752	Wolfpack LiPo 4000mAh 35C 7.4V w/T-Plug	1
755	Wolfpack LiPo 4500mAh 35C 11.1V w/T-Plug	1
758	Wolfpack LiPo 3000mAh 30C 7.4V w/T-Plug	1
759	Wolfpack LiPo 3000mAh 30C 11.1V w/T-Plug	1
27201	324-S AC LiPo/LiFe Compact Balance Charger	1
27202	123-S AC LiPo Compact Balance Charger	1
27203	1416-C2L Dual AC/DC Competition Battery Charger	1
27220	7-in-1 Universal Charge Lead (4mm)	1
27221	T-plug Charge Lead (4mm)	1
27222	XH 2-6S Balance Board (4mm)	1
27223	RX Charger Lead FUT (4mm)	1
27224	US to IEC 320 C5 angle 1M AC Power Cord	1
27226	EU to IEC 320 C5 angle 1M AC Power Cord	1
27233	Reedy 1-2S 4mm/5mm Pro Charge Lead	1
27234	Reedy 4S 5mm Pro Charge Lead	1
27235	Reedy 2S RX/TX Pro Charge Lead	1
27236	Reedy 2S-4S T-plug Pro Charge Lead	1
27237	Reedy 2S-4S XT60 Pro Charge Lead	1
27313	LiPo Pro TX/RX 2400mAh 7.4V Flat	1
27315	LiFe Pro TX/RX 1600mAh 6.6V Flat	1
27318	Wolfpack HV LiPo 50C 4200mAh 7.6V Shorty	1
27358	Zappers SG4 9600mAh 85C 7.6V Stick	1
27359	Zappers SG4 8200mAh 115C 7.6V Stick	1
27360	Zappers SG4 6000mAh 115C 7.6V LP Stick	1
27361	Zappers SG4 5500mAh 85C 7.6V ULP Stick	1
27362	Zappers SG4 5600mAh 85C 7.6V Slim Stick	1
27363	Zappers SG4 6100mAh 85C 7.6V Shorty	1
27364	Zappers SG4 4800mAh 115C 7.6V Shorty	1
27365	Zappers SG4 4100mAh 85C 7.6V LP Shorty	1
27366	Zappers SG4 3600mAh 115C 7.6V LP Shorty	1

:: Reedy Accessories

643	Low Profile Bullet Plug 4mm x 14mm (2)	1
644	Low Profile Bullet Plug 4mm x 14mm (10)	1
645	Low Profile Bullet Plug 5mm x 14mm (2)	1
646	Low Profile Bullet Plug 5mm x 14mm (10)	1
647	Silicone Wire 12AWG-Black (1m)	1
648	Silicone Wire 14AWG-Black (1m)	1
650	Shrink Tubing - 15pcs 4.5mm x 20mm	1
747	Silicone Wire 12AWG-Black (30m)	1
790	Silicone Wire 13AWG-Black (1m)	1
791	Silicone Wire 13AWG-Black (30m)	1
792	Low Profile Caged Bullet Plug 4mm x 14mm (2)	1
794	Low Profile Caged Bullet Plug 5mm x 14mm (2)	1
978	Flat Sensor Wire 70mm	1
979	Flat Sensor Wire 110mm	1
980	Flat Sensor Wire 150mm	1
981	Flat Sensor Wire 200mm	1
982	Flat Sensor Wire 270mm	1
994	Flat Sensor Wire 125mm	1
995	Flat Sensor Wire 175mm	1
27304	LiPo Battery Weight Set - Shorty	1
27355	Shorty Battery Weight Set - 20g, 34g, 50g	1
27356	Stick Battery Weight Set - 29g, 39g, 48g	1
27423	30mm Lightweight Motor Fan w/195mm ext.	1
27457	30mm Aluminum Motor Fan w/195mm extension	1
27458	40mm Aluminum Motor Fan w/195mm extension	1

:: Reedy Motors

293	Sonic 540 FT 17.5 Fixed Timing	1
294	Sonic 540 FT 13.5 Fixed Timing	1
295	Sonic 540-FT Spec Rotor 12.0 x 7.25 x 25.3	1
297	Sonic 540 FT 21.5 Fixed Timing	1
907	540-SL4 3300kV 4-pole Sensorless Brushless Motor	1
27400	S-Plus 25.5 Spec	1
27401	S-Plus 21.5 Spec	1
27402	S-Plus 17.5 Spec	1
27403	S-Plus 13.5 Spec	1
27404	S-Plus 10.5 Spec - Torque	1
27414	540-M3/S-Plus Spec Rotor 12.5 x 7.15 x 24.2	1
27415	540-M3/S-Plus Spec Rotor 12.3 x 7.15 x 24.2	1
27416	540-M3/S-Plus Spec Rotor 12.0 x 7.15 x 24.2	1
27417	S-Plus Screw Set	1
27418	540-M3/S-Plus Lightweight Sensor Board	1
27419	S-Plus Front Plate	1
27420	540-M3/M4/S-Plus Aluminum Case Screw Set	1
27421	540-M3/M4/S-Plus Aluminum Timing Screw Set	1
27425	Reedy Radon2 15T 3-Slot 4100Kv Brushed Motor	1
27426	Reedy Radon2 17T 3-Slot 3600Kv Brushed Motor	1
27427	Reedy Radon2 19T 3-Slot 3200Kv Brushed Motor	1
27428	S-Plus 21.5 Spec - Torque	1
27429	S-Plus 17.5 Spec - Torque	1
27433	Reedy Radon 2 Brush/Spring Set	1
27434	Reedy Radon 2 Wire Set	1
27435	Sonic 540-M4 Modified Motor 21.5	1
27436	Sonic 540-M4 Modified Motor 17.5	1
27437	Sonic 540-M4 Modified Motor 13.5	1
27438	Sonic 540-M4 Modified Motor 9.5	1
27439	Sonic 540-M4 Modified Motor 8.5	1
27440	Sonic 540-M4 Modified Motor 8.0	1
27441	Sonic 540-M4 Modified Motor 7.5	1
27442	Sonic 540-M4 Modified Motor 7.0	1
27444	Sonic 540-M4 Modified Motor 6.5	1
27445	Sonic 540-M4 Modified Motor 6.0	1
27446	Sonic 540-M4 Modified Motor 5.5	1
27447	540-M4 Mod Rotor 12.5 x 7.25 x 25.3	1
27448	540-M4 Mod Rotor 12.5 x 5.0 x 25.3	1
27449	540-M4 Mod Rotor 13.0 x 5.0 x 25.3	1
27450	540-M4 Mod Rotor 12.0 x 5.0 x 25.3	1
27451	Sonic 540-M4 Modified Motor 5.0	1
27452	Sonic 540-M4 Modified Motor 4.5	1
27453	Sonic 540-M4 Modified Motor 4.0	1
27454	Sonic 540-M4 Modified Motor 3.5	1
27455	540-M4 Sensor Board	1
27456	540-M4 Ball Bearing Set	1
27459	Sonic 540-M4 Modified Motor 10.5	1
27460	540-M4 Mod Rotor 12.3 x 5.0 x 25.3	1

:: Reedy Servos

27100	RS1206 Digital HV Hi-Speed Competition Servo	1
27101	RT1508 Digital HV Hi-Torque Competition Servo	1
27102	RS1206 Servo Case Set w/screws	1
27103	RS1206 Servo Gear Set	1
27105	RT1508 Servo Gear Set	1
27107	RT2207A Digital HV Aluminum Hi-Torque Comp Servo	1
27109	RT1408 Digital HV Low-Profile Hi-Torque Comp Servo	1
27110	0712MG Digital RTR Servo	1
27111	1514MG Digital RTR Servo	1
27117	RT3507A Digital HV Aluminum Brushless Servo	1
27118	RS3005A Digital HV Aluminum Brushless Servo	1
27119	RT1705A Digital HV Aluminum Brushless LP Servo	1
27121	RT2207A Gear Set	1
27126	RT1408 Case Set w/screws	1
27128	RT1408 Gear Set	1
27129	0712MG Servo Gear Set	1
27130	1514MG Servo Gear Set	1
27146	RT3507A Gear Set	1
27147	RS3005A Gear Set	1
27148	RT1705A Gear Set	1

:: Tools

1111	FT Turnbuckle Wrench	1
1112	FT 4mm Turnbuckle Wrench	1
1114	FT Dual Turnbuckle Wrench	1
1452	FT TC Ride Height Gauge	1
1498	FT Universal Tire Balancer	1
1499	FT Body Reamer	1
1500	FT 1.5mm Hex Driver	1
1501	FT 2.0mm Hex Driver	1
1502	FT 2.0mm Ball Hex Driver	1
1503	FT 2.5mm Hex Driver	1
1504	FT 2.5mm Ball Hex Driver	1
1505	FT 3.0mm Hex Driver	1
1506	FT 5.0mm Hex Driver	1
1507	FT 5.5mm Nut Driver	1
1508	FT 7.0mm Nut Driver	1
1510	FT 1.5mm Hex Replacement Tip	1
1511	FT 2.0mm Hex Replacement Tip	1
1512	FT 2.0mm Ball Replacement Tip	1
1513	FT 2.5mm Hex Replacement Tip	1
1514	FT 2.5mm Ball Replacement Tip	1
1515	FT 3.0mm Hex Replacement Tip	1
1518	FT Hex Driver Tool Set (3pcs)	1
1519	FT Hex/Nut Driver Tool Set (5pc)	1
1522	FT Digital Scale, 100/0.01g	1
1555	FT Clutch Gauge, 4 Shoe	1
1568	FT 5.5mm Short Nut Driver	1
1569	FT 7mm Nut Driver, T-Handle	1
1570	FT 5.5mm Short Nut Driver	1
1571	FT 1:8 Wheel Nut Wrench, 17mm Hex	1
1579	FT Ball Cup Wrench	1
1595	Chassis Weights, 1/4 oz	1
1650	7 Piece Hex Driver Set	1
1657	FT 1/4" Hex Drive .050" Tip	1
1659	FT 1/4" Hex Drive 5/64" - 2.0mm Tip	1
1661	FT 1/4" Hex Drive 1.5mm Tip	1
1662	FT 1/4" Hex Drive 2.5mm Tip	1
1666	FT 1/4" Hex Drive 5.5mm Nut Driver Tip	1
1667	FT 1/4" Hex Drive 7.0mm Nut Driver Tip	1
1668	FT 1/4" Hex Drive 8.0mm Nut Driver Tip	1
1674	FT 1/4" 5 Piece Power Tool Tips Set (5/64"-2.0mm, 1.5mm, 2.5mm, 5/64"- 2.0mm ball, 2.5mm ball)	1
1679	FT T-Handle Ratchet Driver	1
1737	FT Body Scissors	1
3987	FT Droop Gauge	1
89240	RC8 FT Turnbuckle Wrench	1

:: Contact Information

Check out the following web sites for all of our electric kits, current products, new releases, setup help, tips, and racing info!

Associated Electrics, Inc.

21062 Bake Parkway

Lake Forest, CA 92630-8853 USA

<http://www.TeamAssociated.com>

<http://www.RC10.com>

http://twitter/Team_Associated

<http://www.instagram.com/teamassociatedrc/>

<http://www.facebook.com/TeamAssociated/>

call: (949) 544-7500

fax: (949) 544-7501

TEAM ASSOCIATED

WORLD CHAMPION R/C CARS

Associated Electrics, Inc.
21062 Bake Parkway Lake Forest, CA 92630 USA

call: (949) 544-7500 - fax: (949) 544-7501
Check out the following web sites for all of our kits,
current products, new releases, setup help, tips, and racing info!
www.AssociatedElectrics.com

FOLLOW US ON SOCIAL MEDIA



TeamAssociated
ReedyPower
ElementRC



@TeamAssociatedRC
@ReedyPower
@Element_RC



@Team_Associated
@ReedyPower



AEFactoryTeam