



:: Front Suspension

anti-roll bar: 2.2 - black
 2.5 - silver
 2.8 - gold

front body mount hole: 

steering rack:  back
mid
front

hinge pin bushing: # _____
 up down

camber: _____

caster: _____

toe: _____

kickup bushing: # _____
 up down

ride height: _____

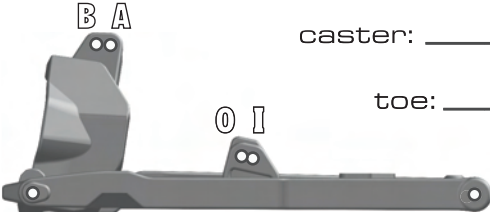

:: Rear Suspension

anti-roll bar: 2.2 - black
 2.5 - silver
 2.8 - gold

wheelbase: long
 medium
 short

rear body mount hole: 

camber: _____

toe: _____

hub: upper
lower

ride height: _____

anti-squat bushing: # _____
 up down

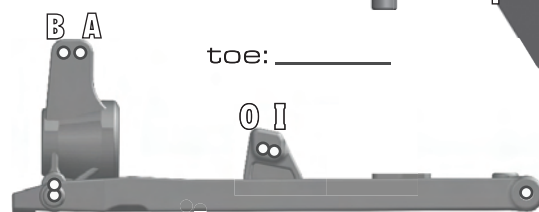

:: Front Shocks

spring: _____ piston: _____
shock fluid: _____ length: _____
shock cap: _____

:: Rear Shocks

spring: _____ piston: _____
shock fluid: _____ length: _____
shock cap: _____

:: Differentials

front fluid: _____
center fluid: _____
rear fluid: _____

:: Wing

location: forward back
angle: low med. high
type: _____

:: Chassis Braces

standard molded aluminum
other: _____

:: Engine

engine: _____ restrictor: _____
muffler: _____ temp: _____
glow plug: _____
fuel: _____

:: Gearing/Clutch

gearing: _____
shoes: _____ x aluminum _____ x fiber
spring: _____ x .9mm _____ x 1.0mm _____ x 1.1mm
notes: _____

:: Notes

:: Tires

tire (F/R): _____ / _____
compound (F/R): _____ / _____
insert: _____ wheel: _____

:: Race and Vehicle Comments

qualify: _____ main: _____ finish: _____ tq:
comments: _____

:: Track Info

traction: high med. low
surface: smooth bumpy
 blue groove soft dirt grass
 clay wet dusty
other: _____
