



# SC18

SHORT COURSE

#20120



1:18 Scale Electric 4WD Offroad Race Truck Manual & Catalog

12/09

# TEAM ASSOCIATED



## :: Introduction

Thank you for purchasing this Team Associated product. This manual contains instructions and tips for building and maintaining your new SC18. Please take a moment to read through it and familiarize yourself with these steps. We are continually changing and improving our designs; therefore, actual parts may appear slightly different than the illustrations. New parts will be noted on supplementary sheets located in the appropriate parts bags. Check each bag for these sheets before you start to build.

## :: SC18 Features

- Realistic short course racing truck 0.8mm (0.03") polycarbonate body
- AMT™ Forged style wheels front and rear
- Aggressive tread multi-terrain scale tires
- Realistic bumpers front and rear for maximum durability
- Rubber AE logo mud flaps
- 2.0:1 ratio gearbox equipped with durable gear differential
- Molded composite chassis with sealed drive train
- 2-belt drive system for ultimate durability capable of handling all brushless/lipo combos
- Dual bell crank steering for improved steering feel
- Hinged battery strap for quick battery changes
- Durable front and rear body mounts with adjustable height
- Complete set of 15 steel shielded ball bearings
- Durable fixed length composite turnbuckles
- Improved servo saver for better straight line tracking
- Vertical ball end adjustment front and rear
- Composite shock bodies with molded pre-load clips
- Dog bone front and rear axles
- Fully licensed bodies available as option parts (Lucas Oil, Pro-Comp, Bully Dog, KMC, AE...)

## :: Additional

### :: SC18 RTR

Your new SC18 RTR comes factory assembled including radio gear, motor, ESC, and battery. However, you will need to purchase 8 AA batteries Alkaline or Nimh rechargeable (AE Part # 302, 303) for your transmitter. Please see the Quick Start Guide for installing your AA batteries.

Tools included:

- 4-way wrench
- hex wrenches: (1.5mm, 5/32" [2mm])

**There is a 1:1 fold out  
in the back of the manual.  
Fold it out while building your  
kit for easy hardware sizing!**

## :: Optional

Optional parts and gear to accessorize and maintain your SC18:

- Green Slime shock lube (AE Part# 1105)
- Cyanoacrylate glue
- Thread Locking Compound (AE Part# 1596)
- Silicone Shock Fluid (Refer to catalog for complete listings)
- Body Scissors (AE Part# 1737)
- Reamer / Hole Punch
- FT Hex Wrenches (AE Part# 1541)
- FT Screwdriver Set (AE Part# 1551)
- FT Nut Driver Set (AE Part# 1561)
- Hobby Knife
- Needle Nose Pliers
- Wire Cutters
- Soldering Iron
- Calipers or a Precision Ruler
- SC18 CVD kit (AE Part# 21380)
- FT Ball Differential Kit (AE Part# 21381, 21408)
- FT Anti-Roll Bar Kit (AE Part# 21386)
- FT Graphite Chassis Conversion Kit (AE Part# 21402)
- Titanium Turnbuckle Set w/Ball Cups (AE Part# 21403)
- FT Slipper Shaft Assembly (AE Part# 21405)



\* These Symbols Indicate a special note or instructions.

**Associated Electrics, Inc.**  
26021 Commercentre Dr.  
Lake Forest, CA 92630



**Customer Service**  
Tel: 949.544.7500  
Fax: 949.544.7501

<http://www.TeamAssociated.com> • <http://www.RC10.com> • [http://twitter.com/Team\\_Associated](http://twitter.com/Team_Associated) • <http://bit.ly/AEonFacebook>

## :: Shock Build

### STEP 1

21192 shock piston

21192 x2 e-clip

21192 shock shaft

21181 shock body

21332 x2 shock o-ring

21192 shock body seal cap

(#5422)30wt shock fluid

(#5422)30wt shock fluid

21189 ball cup, short

Cap should "snap" into place.

Grip shaft (where shown) with needlenose pliers.

## :: Shock Build (cont.)

### STEP 2

(#5422)30wt shock fluid

! Fill to top with oil.

! Move shaft up and down to remove air bubbles.

(#5422)30wt shock fluid

! Fill to top with oil.

! Install bladder.

21192 shock bladder

## :: Shock Build (cont.)

### STEP 3

! Retain oil as you screw the shock cap on.

21182 shock cap

21191 ride height clips

21191 upper spring perch

**Front** 21198 spring (blue)

**Rear** 21197 spring (silver)

21191 lower spring retainer

**Builds 4**

## :: Differential Build

STEP 1

21319  
gear diff  
(sun)

21318  
gear diff  
case

21141  
diff shim

21106  
bearing  
(8x12x3.5)

21317  
gear diff  
outdrive

! Outdrive should "snap" into sun gear.

front

21319  
gear diff  
(sun)

21135 x4  
M2x12mm  
fhps

21141  
diff shim

21106  
bearing  
(8x12x3.5)

black grease #6588

21318  
gear diff  
case, front  
(narrow)

! Outdrive should "snap" into sun gear.

21317  
gear diff  
outdrive

rear

21319  
gear diff  
(sun)

21135 x4  
M2x12mm  
fhps

21141  
diff shim

21106  
bearing  
(8x12x3.5)

21317  
gear diff  
outdrive

black grease #6588

21407  
gear diff  
case, rear  
(wide)

## :: Differential Build (cont.)

STEP 2

21319 x4  
gear diff  
(planet)

! \* Align slots in cross pins.

21319 x2  
gear diff  
cross pin

black grease #6588

front

rear

**Builds Front and Rear Diffs**

## :: Gearbox Install

STEP 1

front

21337  
bearing  
(3x6x2.5)

21130  
M2x3mm  
bhps

21312  
front  
gearbox

21314  
belt  
tensioner  
nut

21314  
belt  
tensioner

21334  
M2x6mm  
fhps

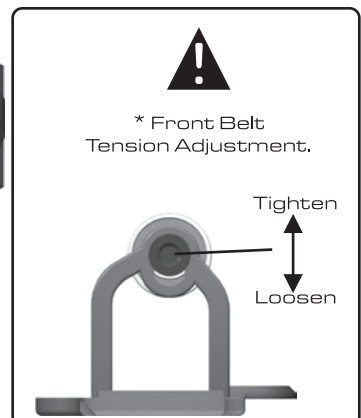

**:: Gearbox Install (cont.)**

STEP 2

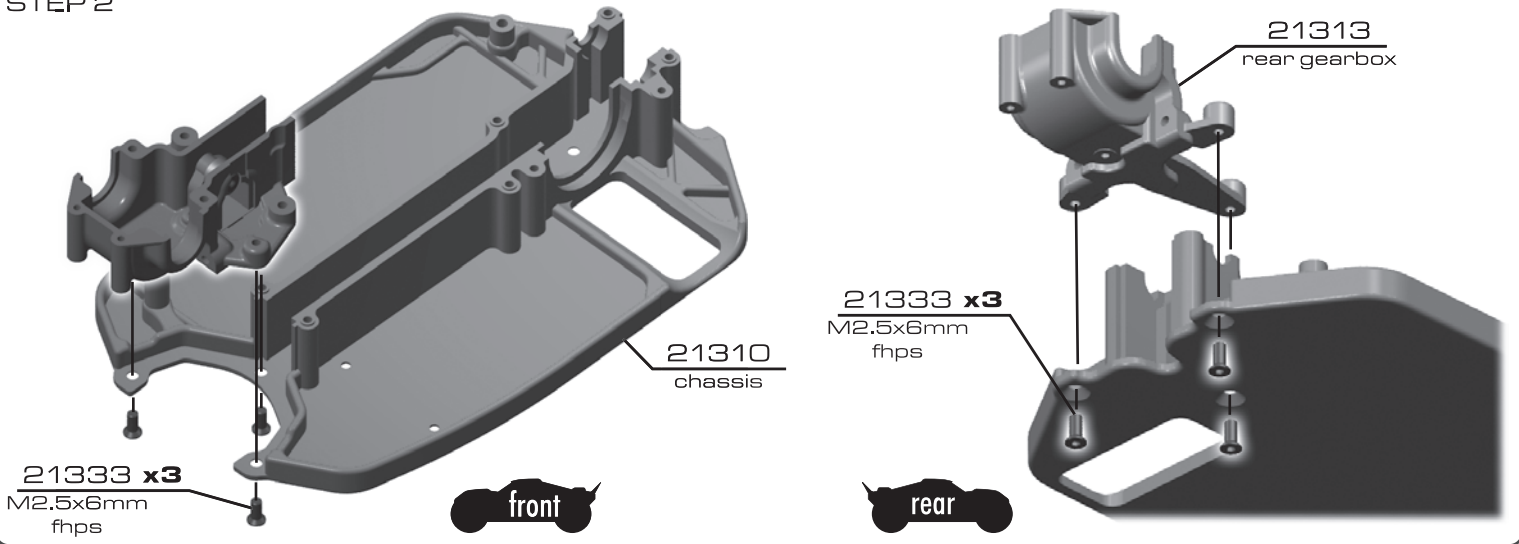

**:: Steering System Build**

STEP 1

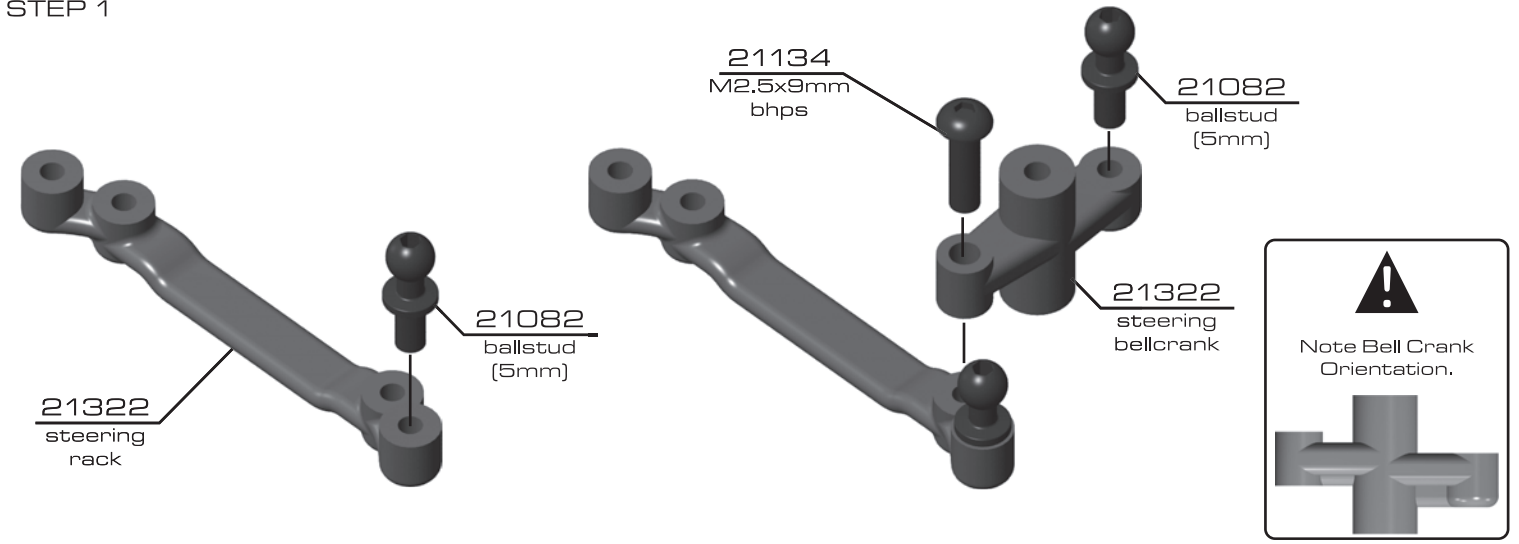

**:: Steering System Build (cont.)**

STEP 2

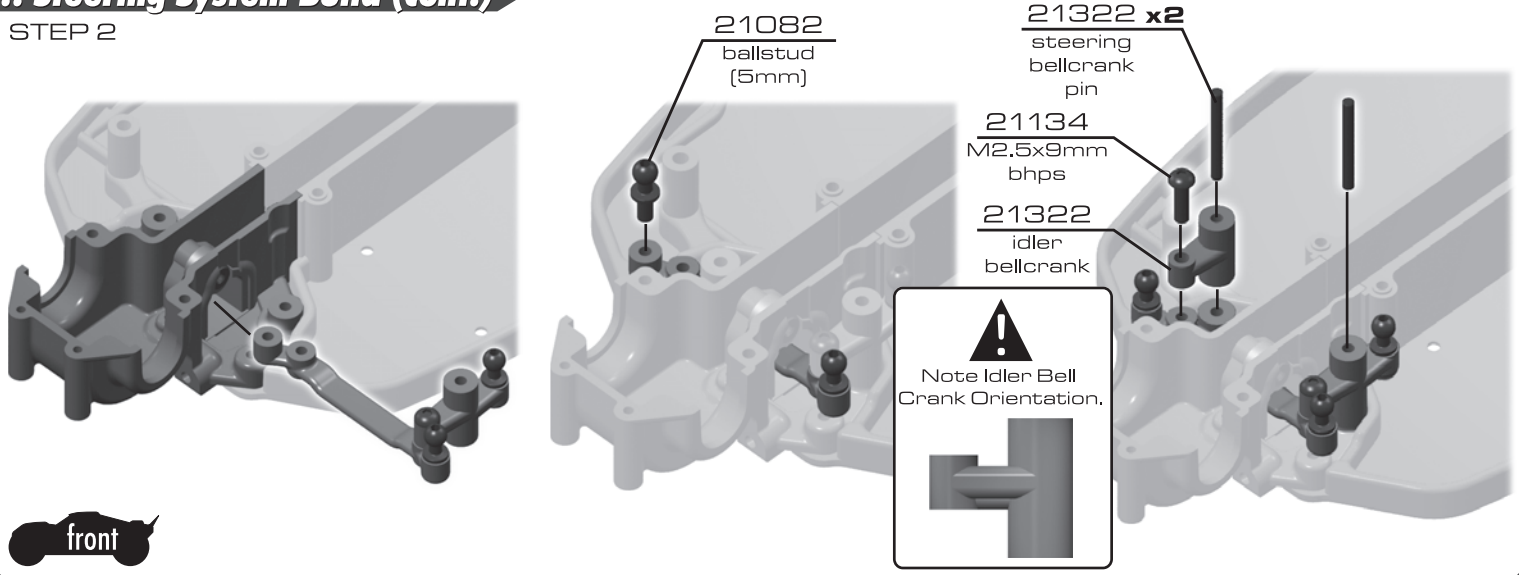

**:: Spur Gear Build**

STEP 1

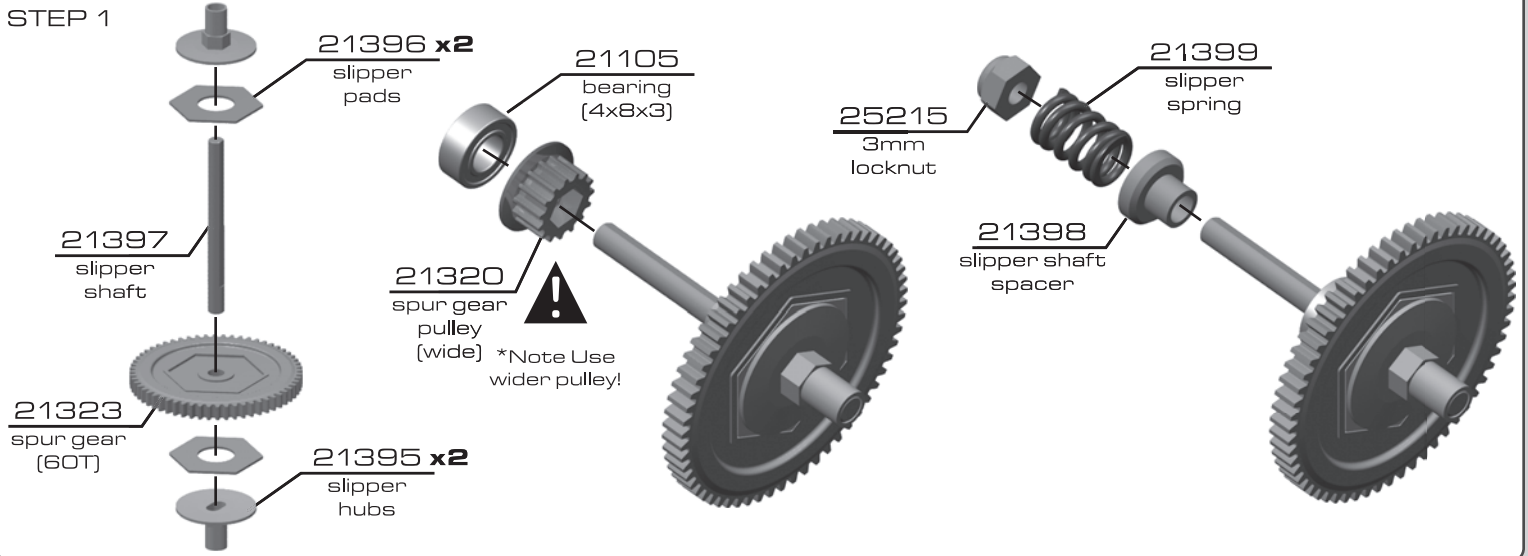

**:: Spur Gear Build (cont.)**

STEP 2

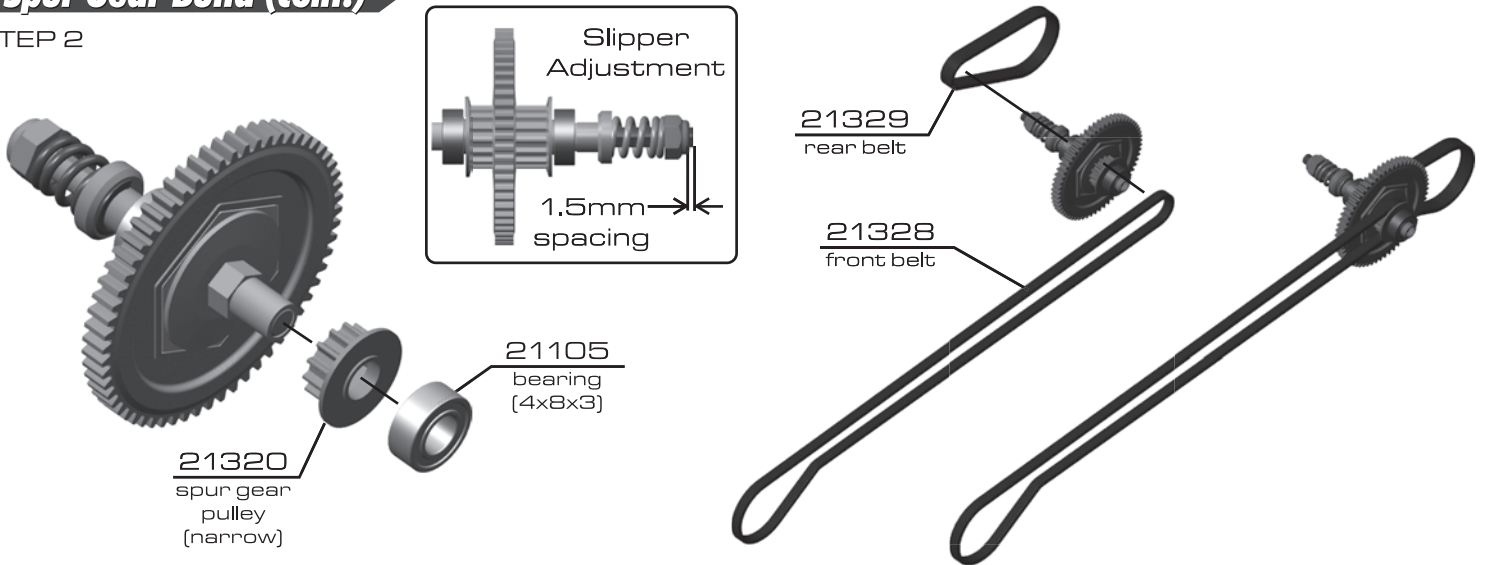

**:: Spur Gear Build (cont.)**

STEP 3

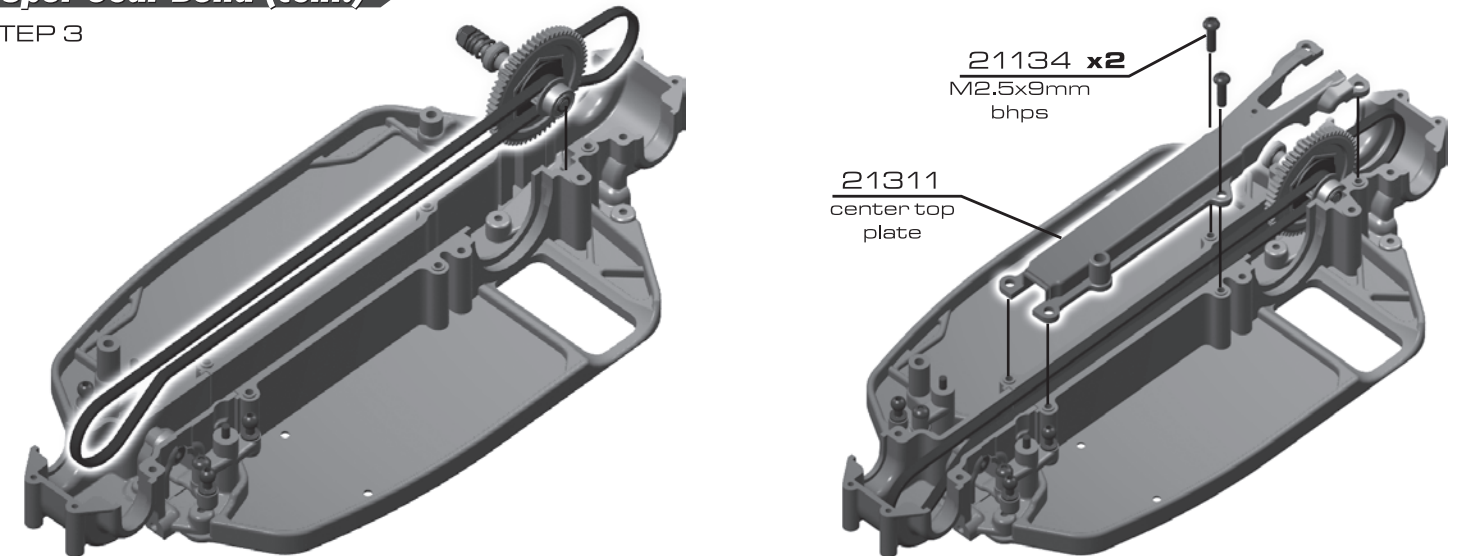

## :: Differential Install

STEP 1

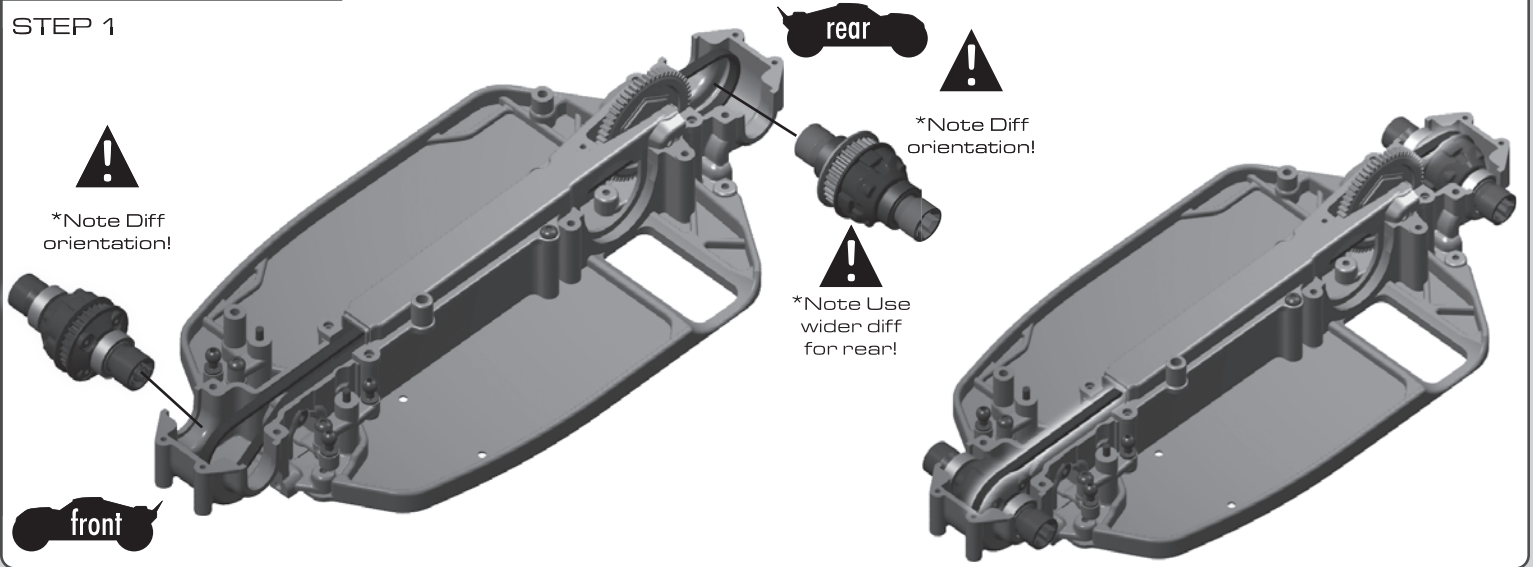

## :: Differential Install (cont.)

STEP 2

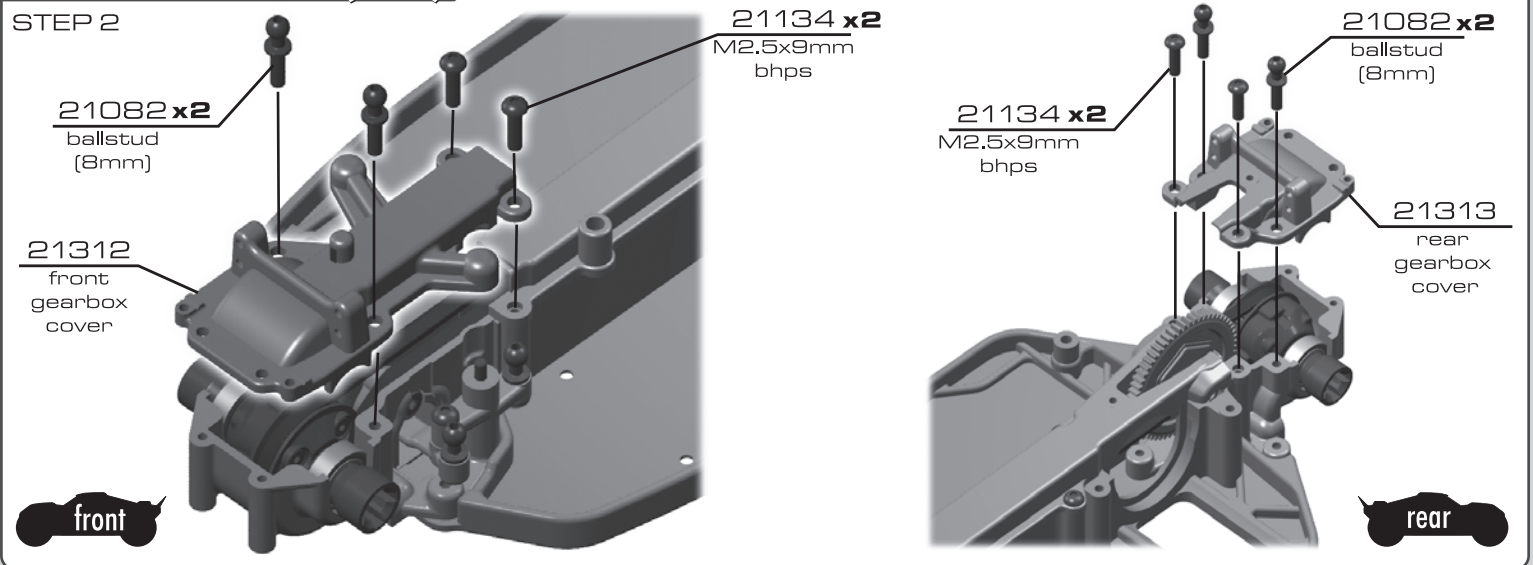

## :: Shock Tower Build

STEP 1

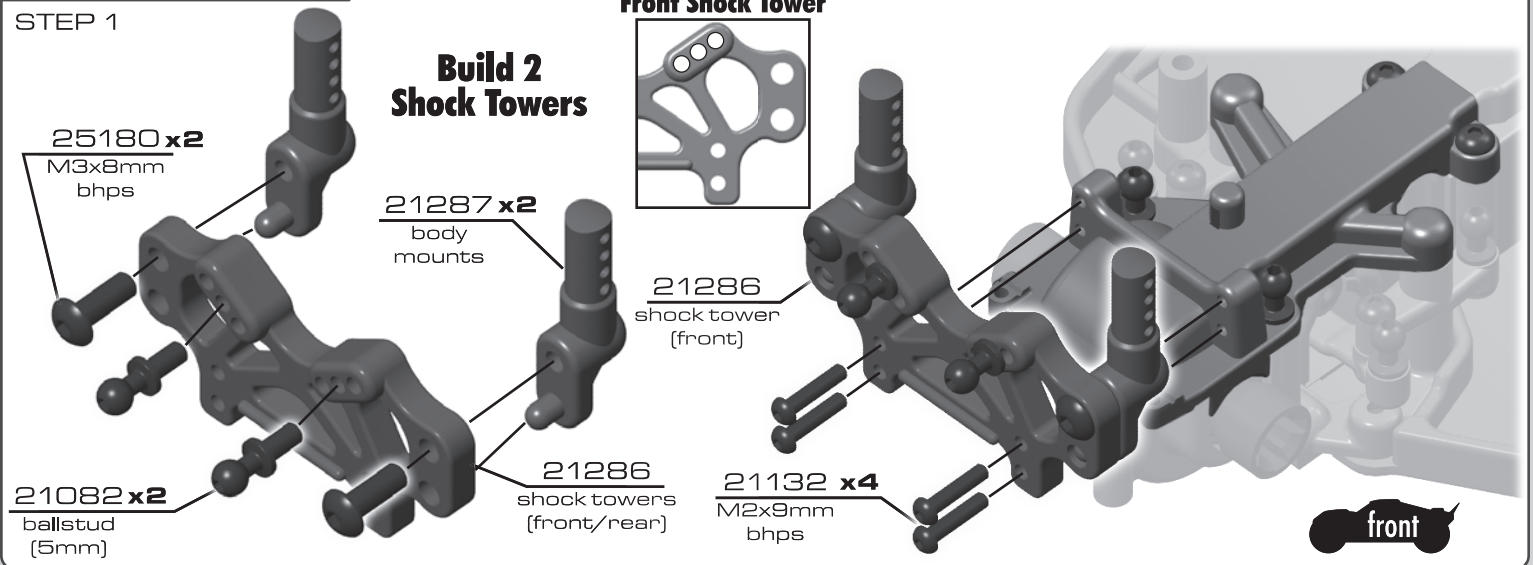

**:: Shock Tower Build (cont.)**

STEP 2

**Rear Shock Tower**

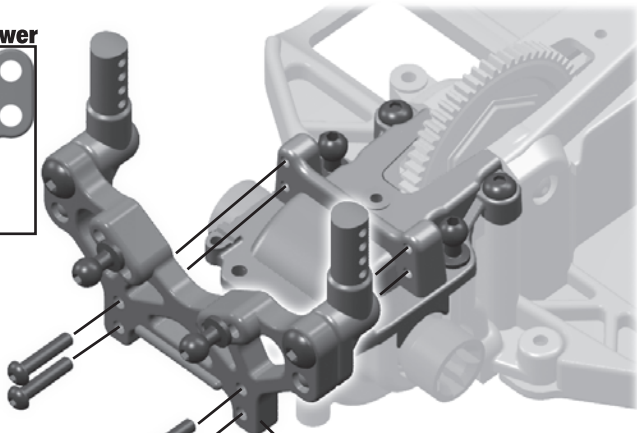
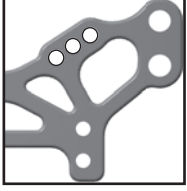

**21132 x4**  
M2x9mm  
bhps

**21286**  
shock tower  
(rear)



**:: Bumpers**

STEP 1

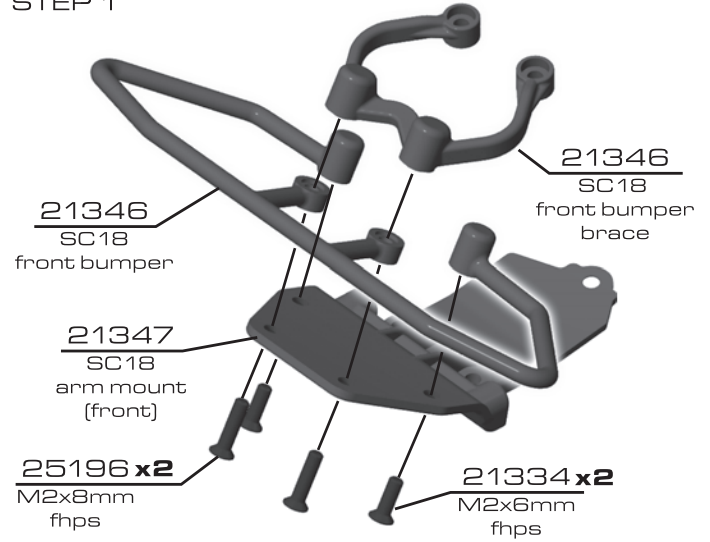

**21346**  
SC18  
front bumper

**21346**  
SC18  
front bumper  
brace

**21347**  
SC18  
arm mount  
(front)

**25196 x2**  
M2x8mm  
fhps

**21334 x2**  
M2x6mm  
fhps

**:: Bumpers (cont.)**

STEP 2

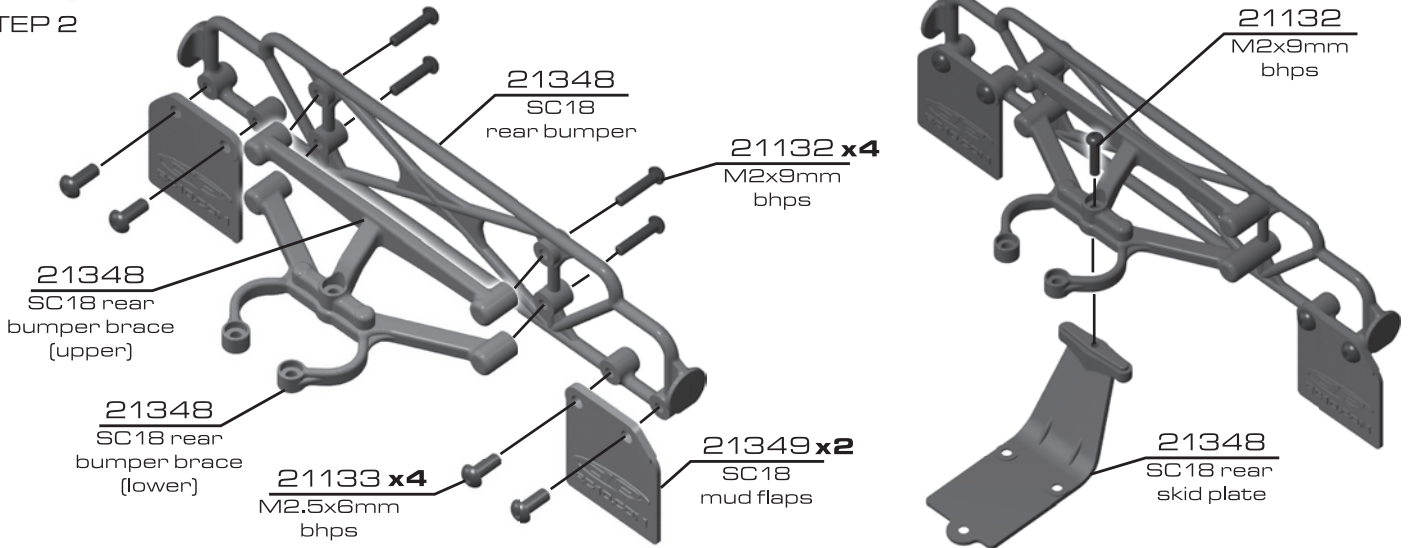

**21348**  
SC18  
rear bumper

**21132 x4**  
M2x9mm  
bhps

**21348**  
SC18 rear  
bumper brace  
(upper)

**21348**  
SC18 rear  
bumper brace  
(lower)

**21133 x4**  
M2.5x6mm  
bhps

**21349 x2**  
SC18  
mud flaps

**21132**  
M2x9mm  
bhps

**21348**  
SC18 rear  
skid plate

**:: Suspension Arms Install**

STEP 1

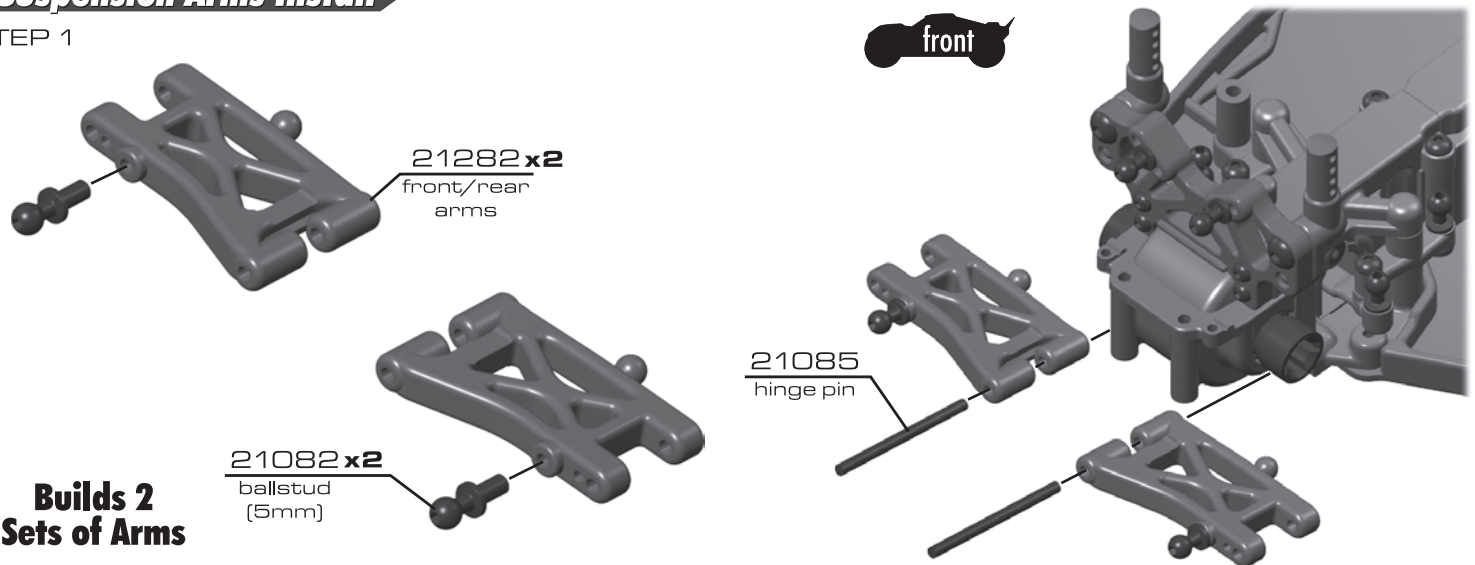

**21282 x2**  
front/rear  
arms

**Builds 2  
Sets of Arms**

**21082 x2**  
ballstud  
(5mm)

**21085**  
hinge pin





**:: Suspension Arms Install (cont.)**

STEP 2

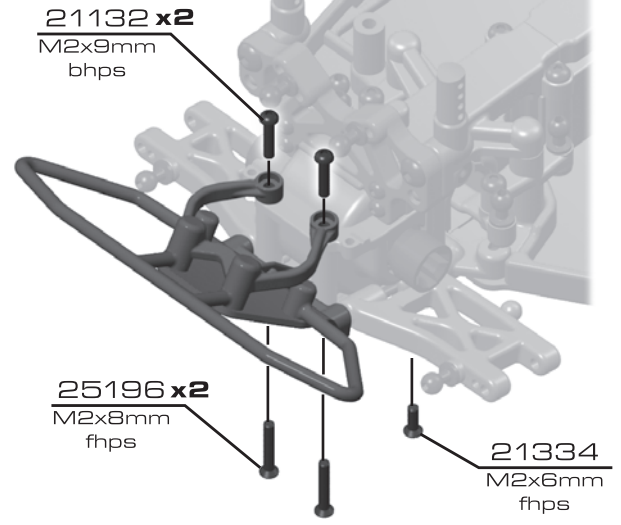
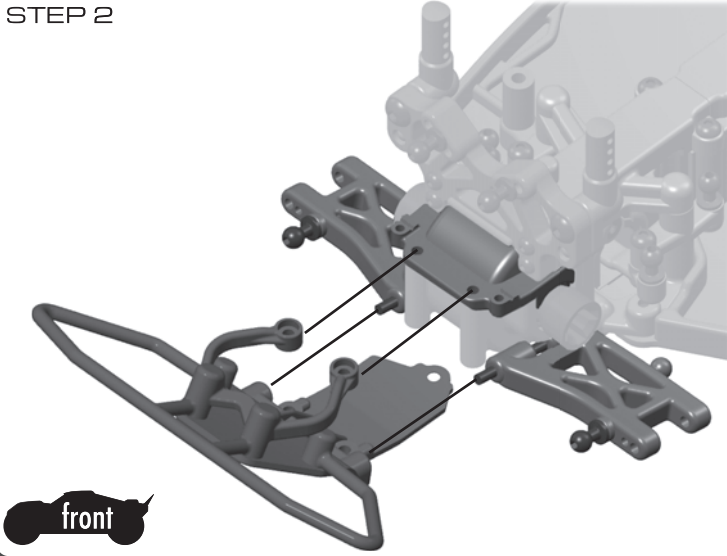

**:: Suspension Arms Install (cont.)**

STEP 3

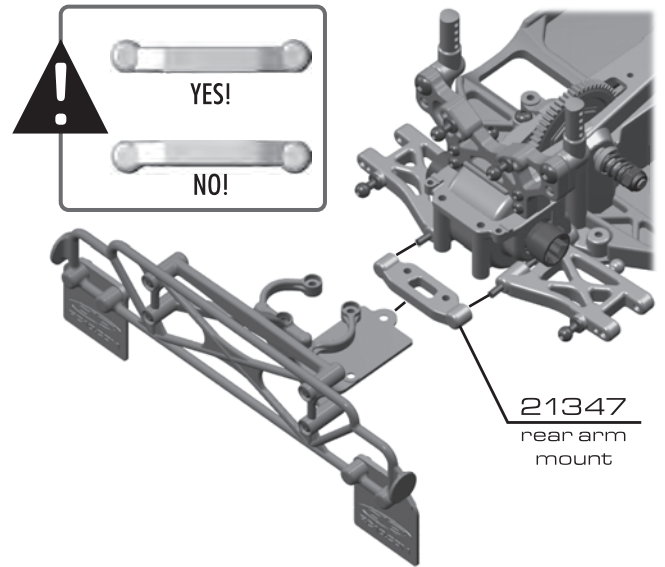
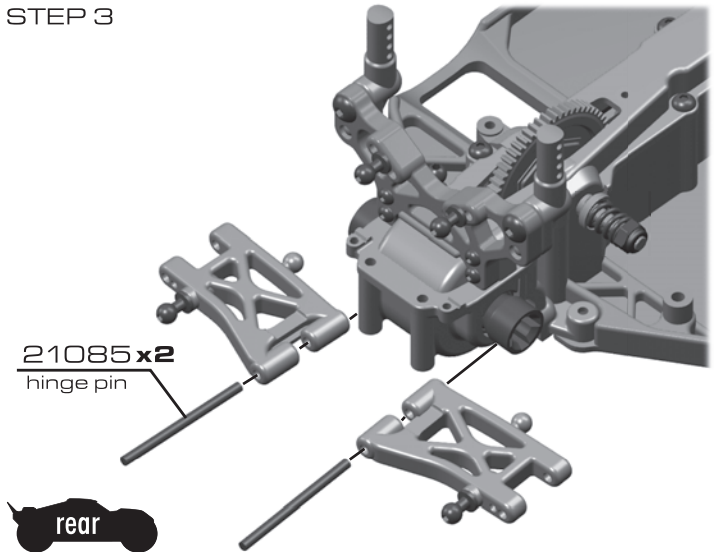

**:: Shock Tower Build**

STEP 4

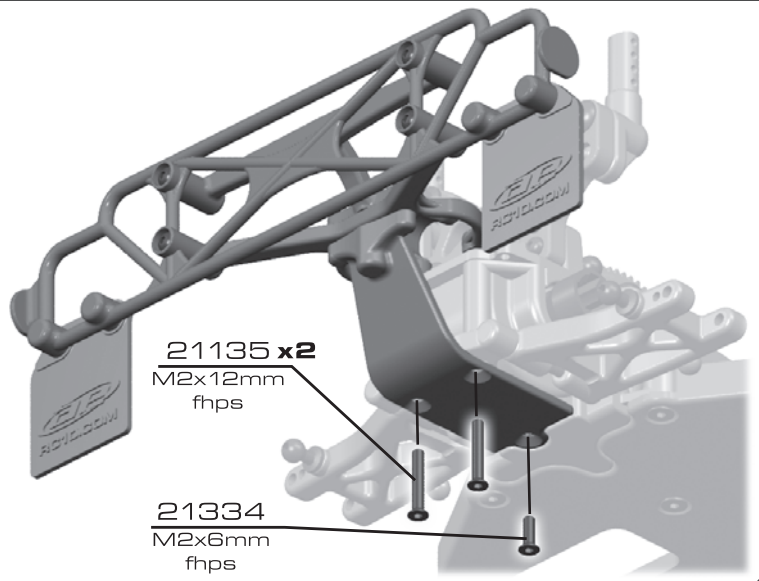
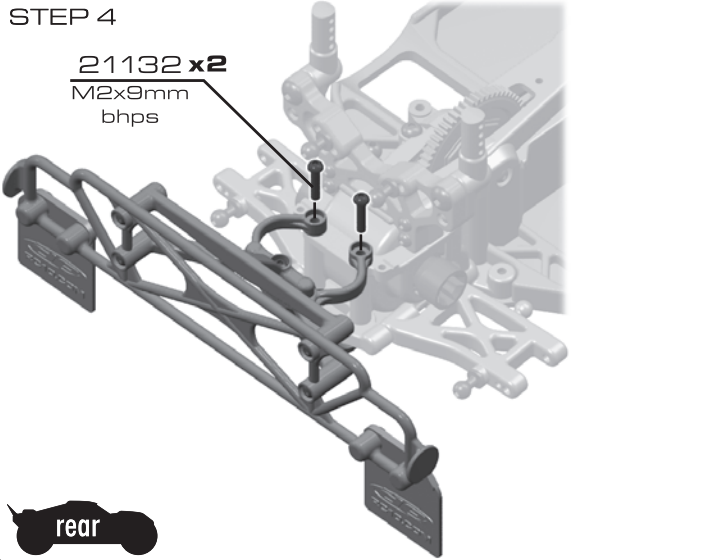

**:: Caster Blocks Build**

STEP 1

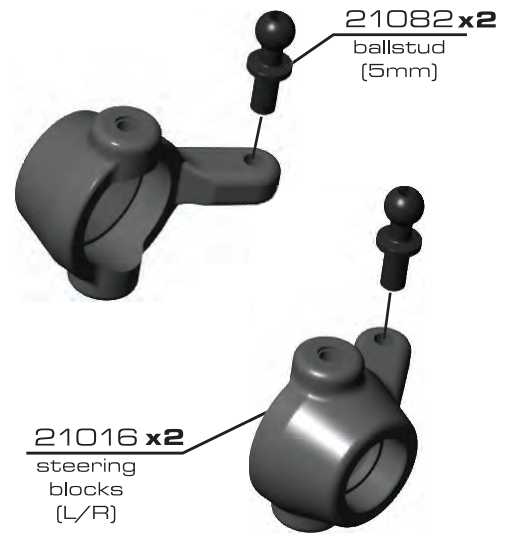
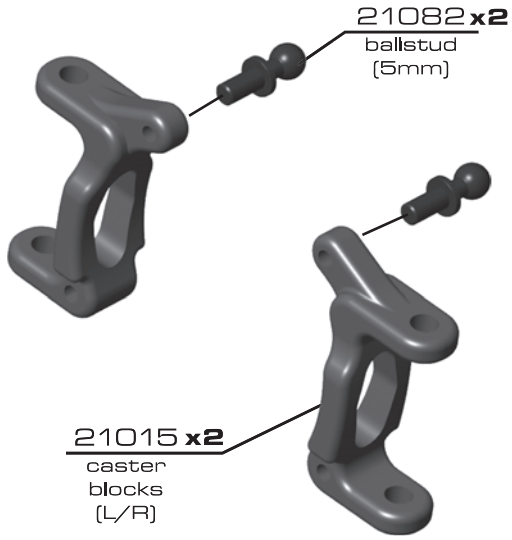

**:: Caster Blocks Build (cont.)**

STEP 2

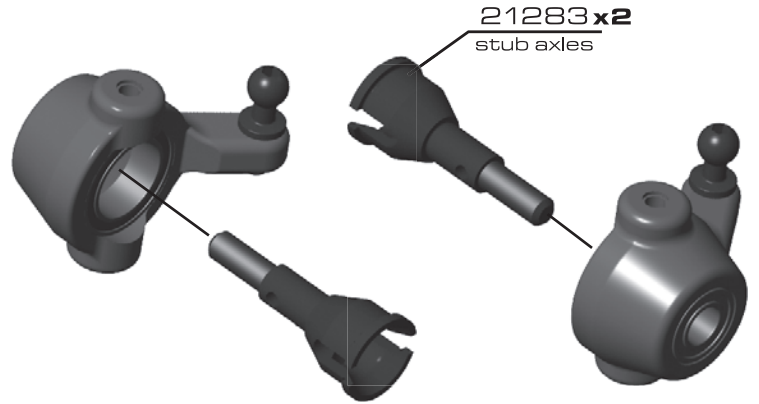
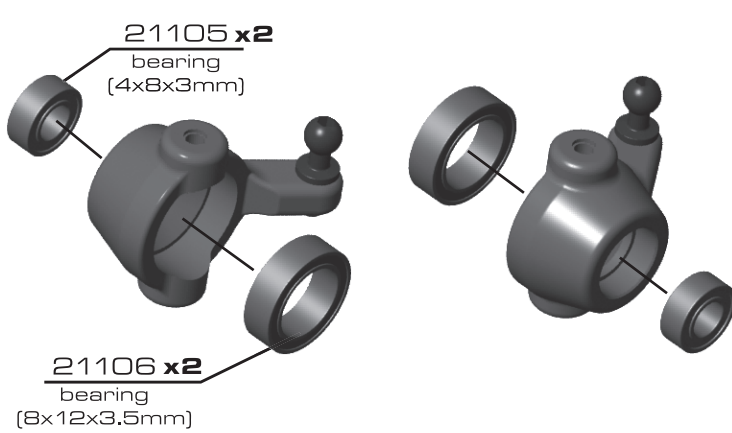

**:: Caster Blocks Build (cont.)**

STEP 3



\*Do not over-tighten  
these 4 screws!.

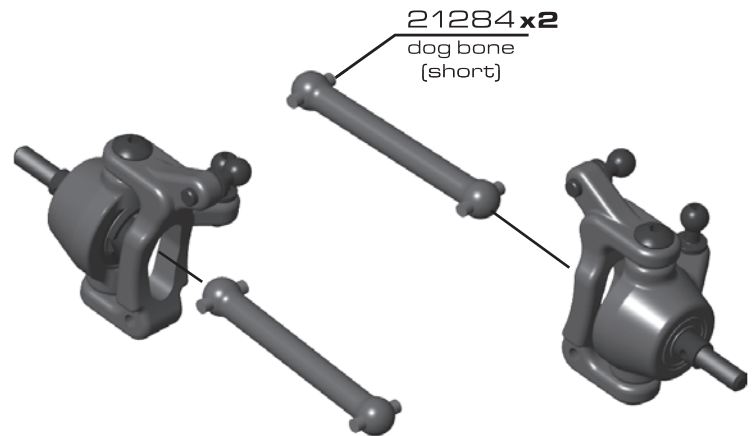
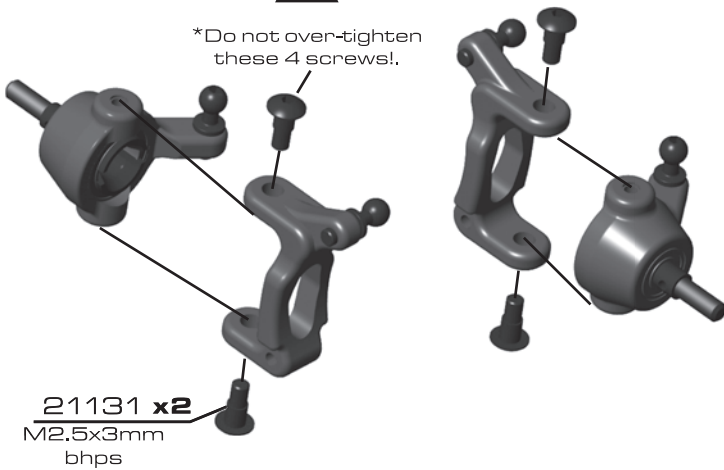

## :: Caster Blocks Install

STEP 1

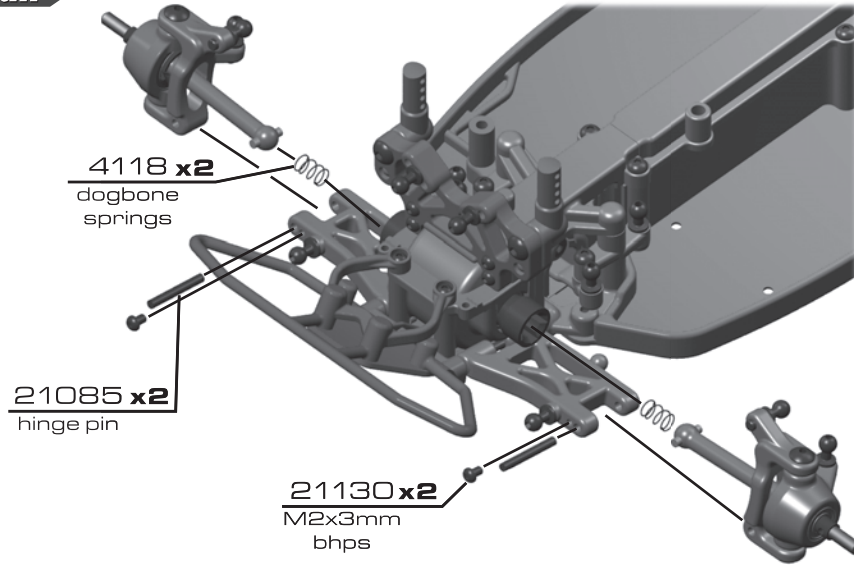

## :: Caster Blocks Install (cont.)

STEP 2

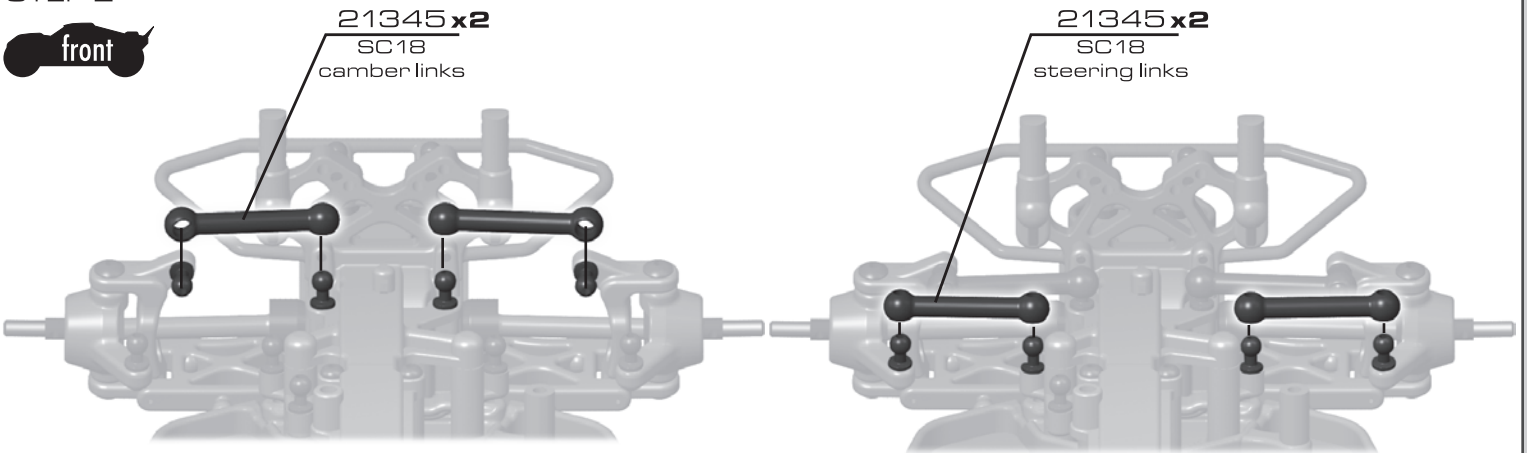

## :: Rear Hubs Build

STEP 1

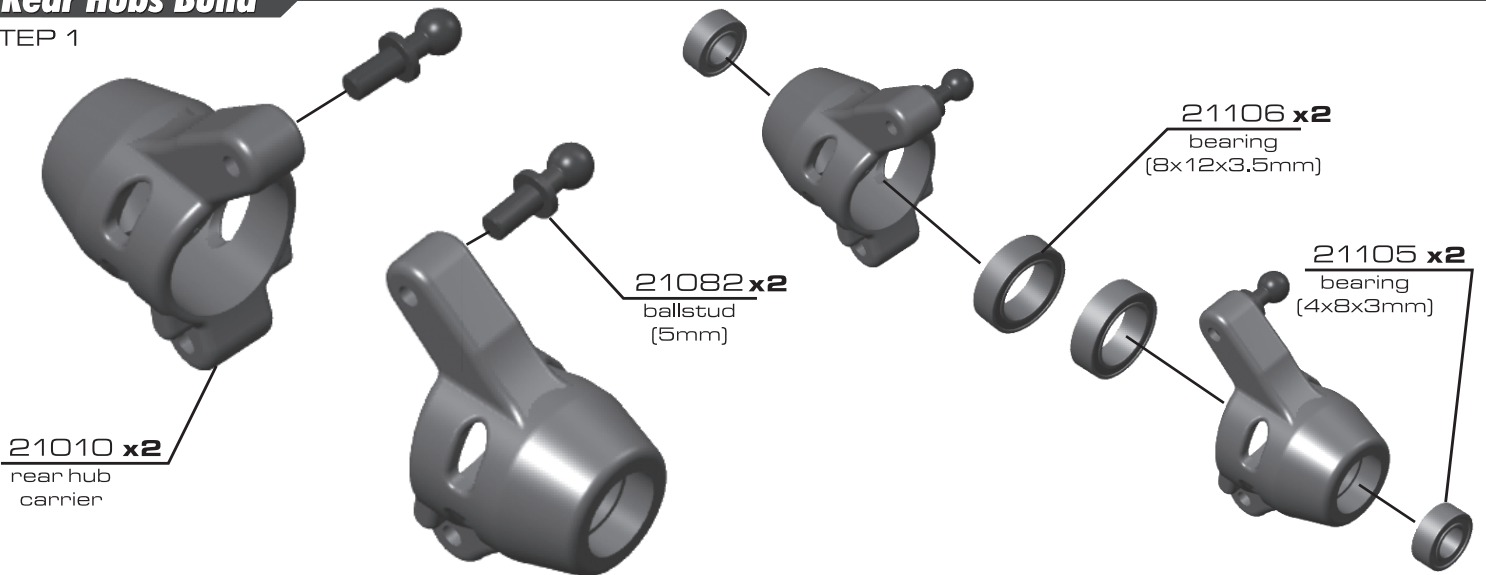

**:: Rear Hubs Build (cont.)**

STEP 2

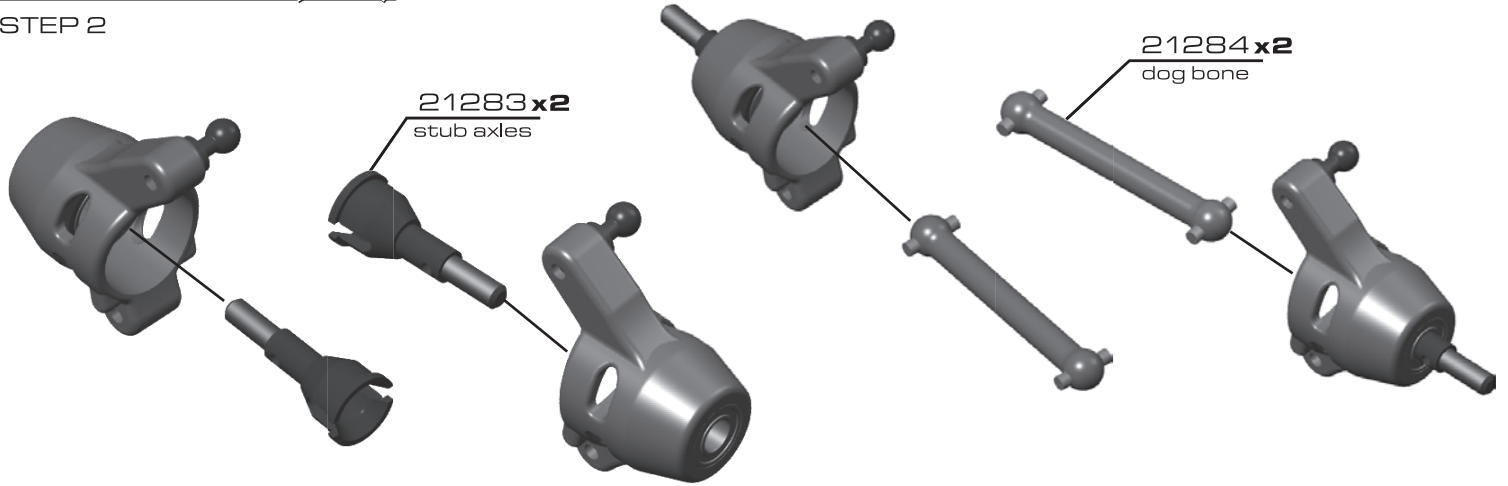

**:: Rear Hubs Install**

STEP 1

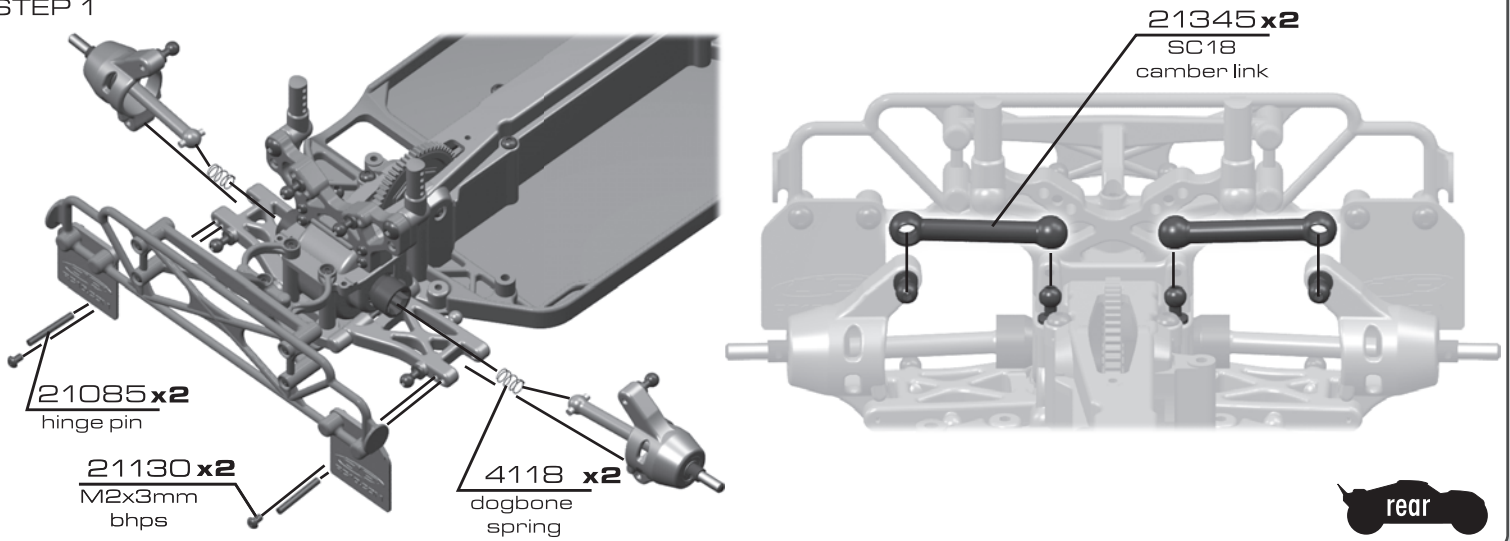

**:: Shocks Install**

STEP 1

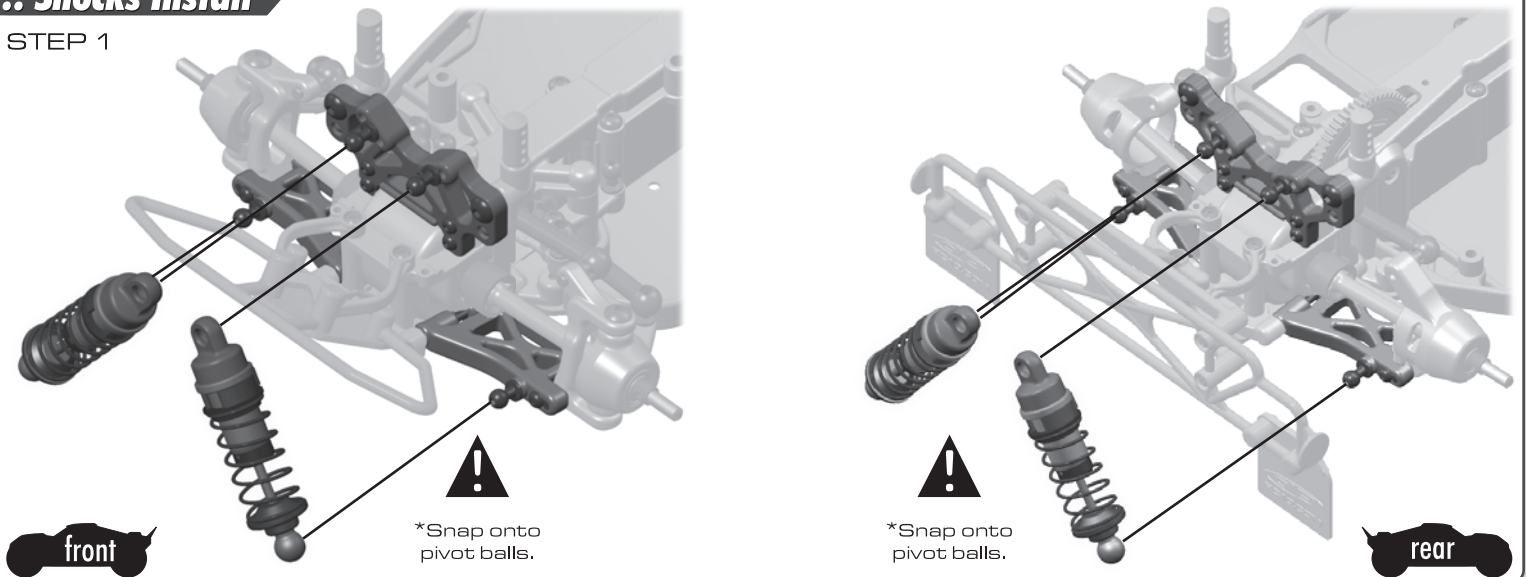

## :: Servo Install

STEP 1

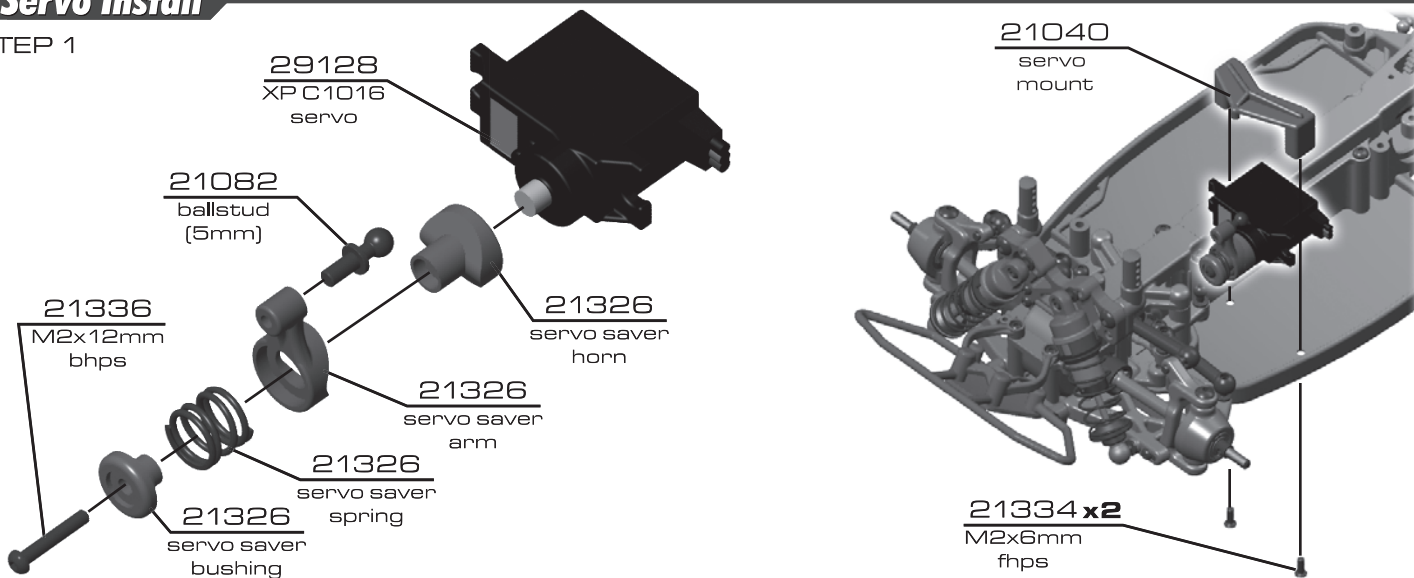

## :: Servo Install (cont.)

STEP 2

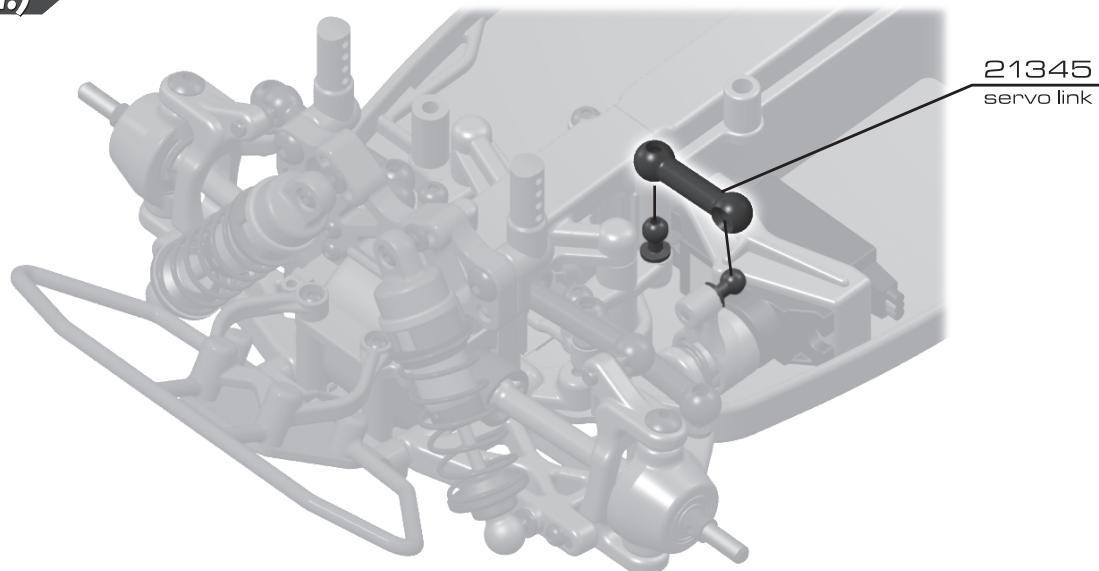

## :: Motor Install

STEP 1

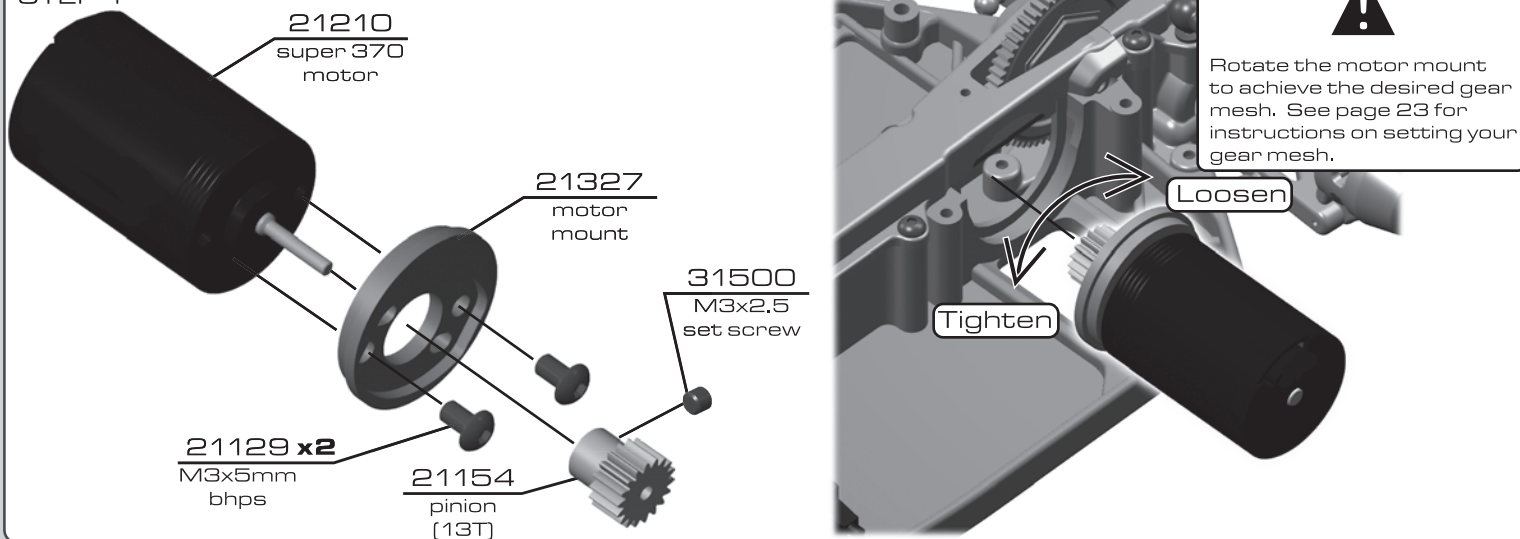

**:: Motor Install (cont.)**

STEP 2

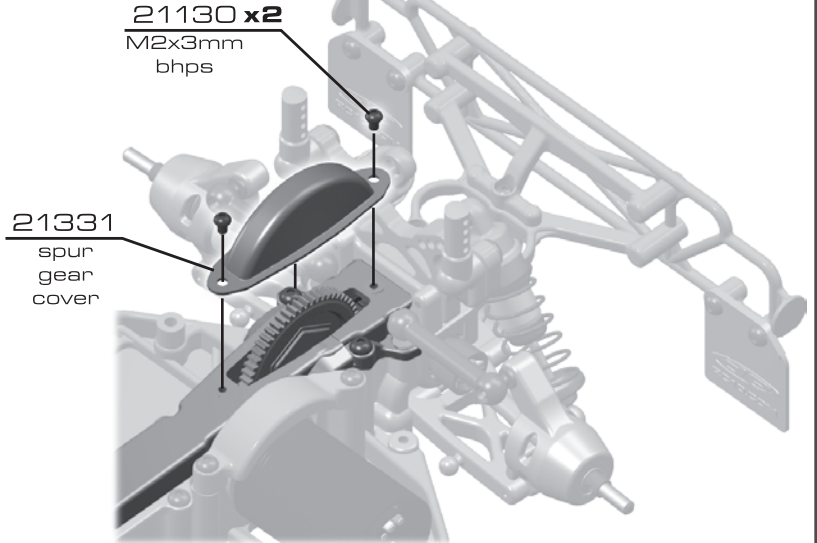
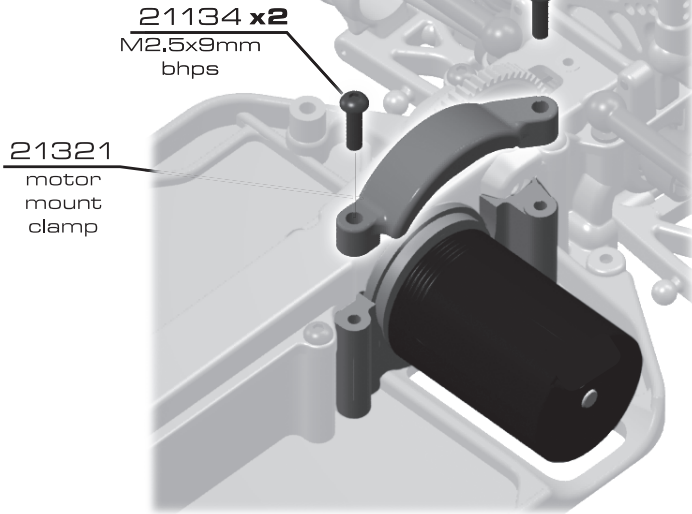

**:: Electronics Install**

STEP 1

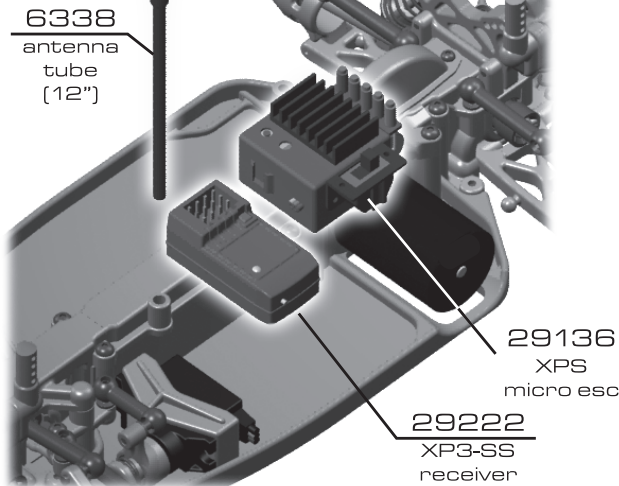

**:: Electronics Install (cont.)**

STEP 2

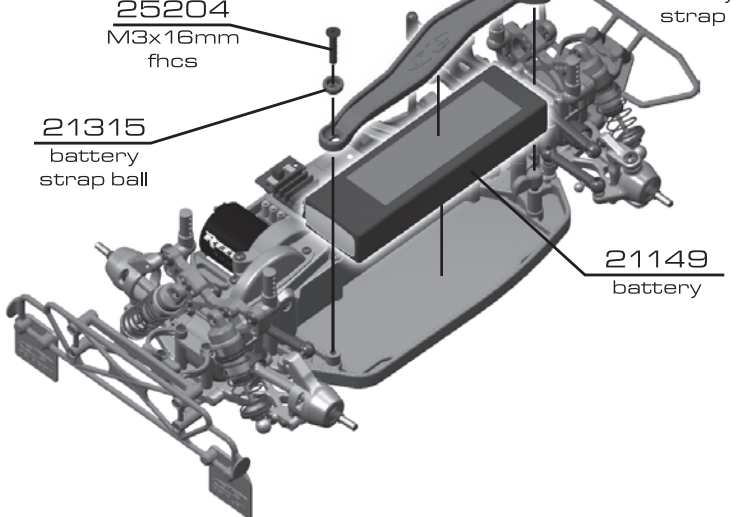

  
Twist clockwise  
to lock battery  
strap in place.

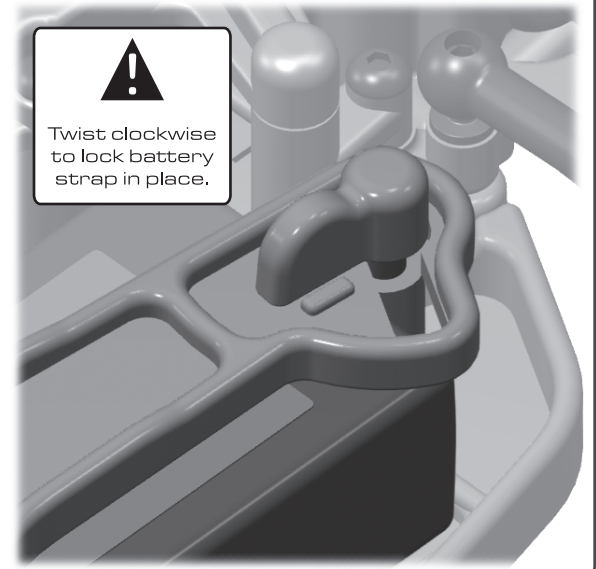

### :: Tires and Wheels

STEP 1

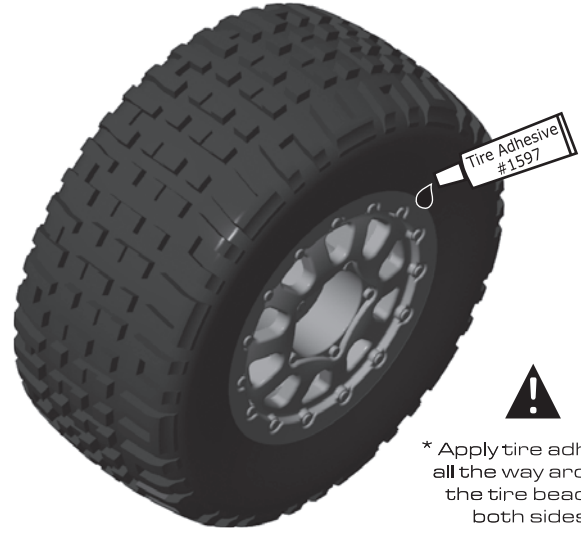
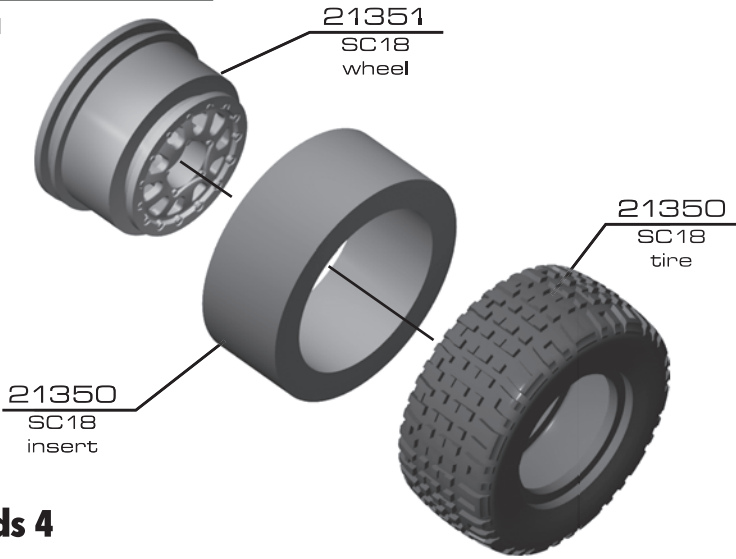

\* Apply tire adhesive all the way around the tire bead on both sides.

**Builds 4**

### :: Tires and Wheels (cont.)

STEP 2

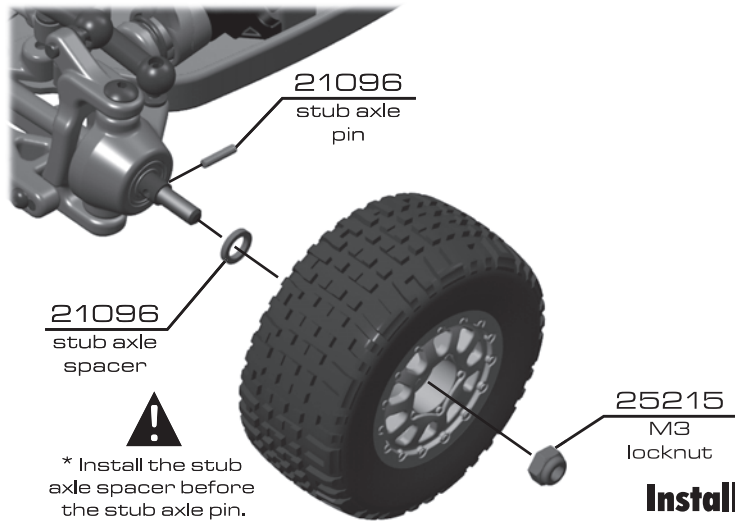

\* Install the stub axle spacer before the stub axle pin.

**Install x4**

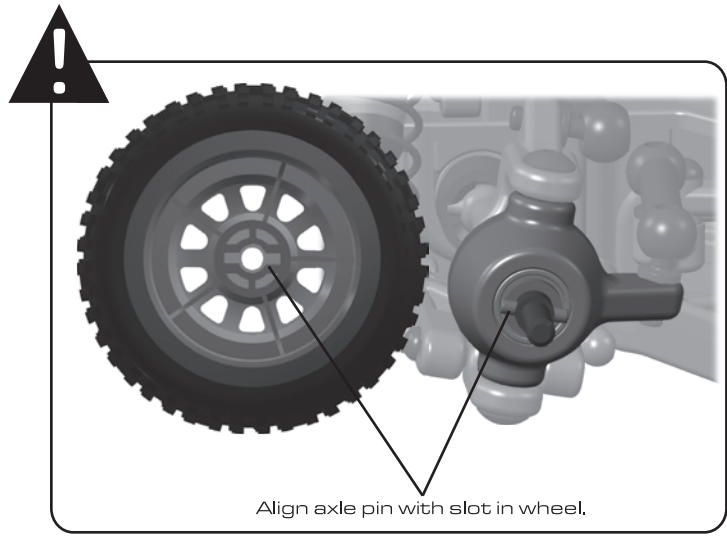

### :: Body Install

STEP 1

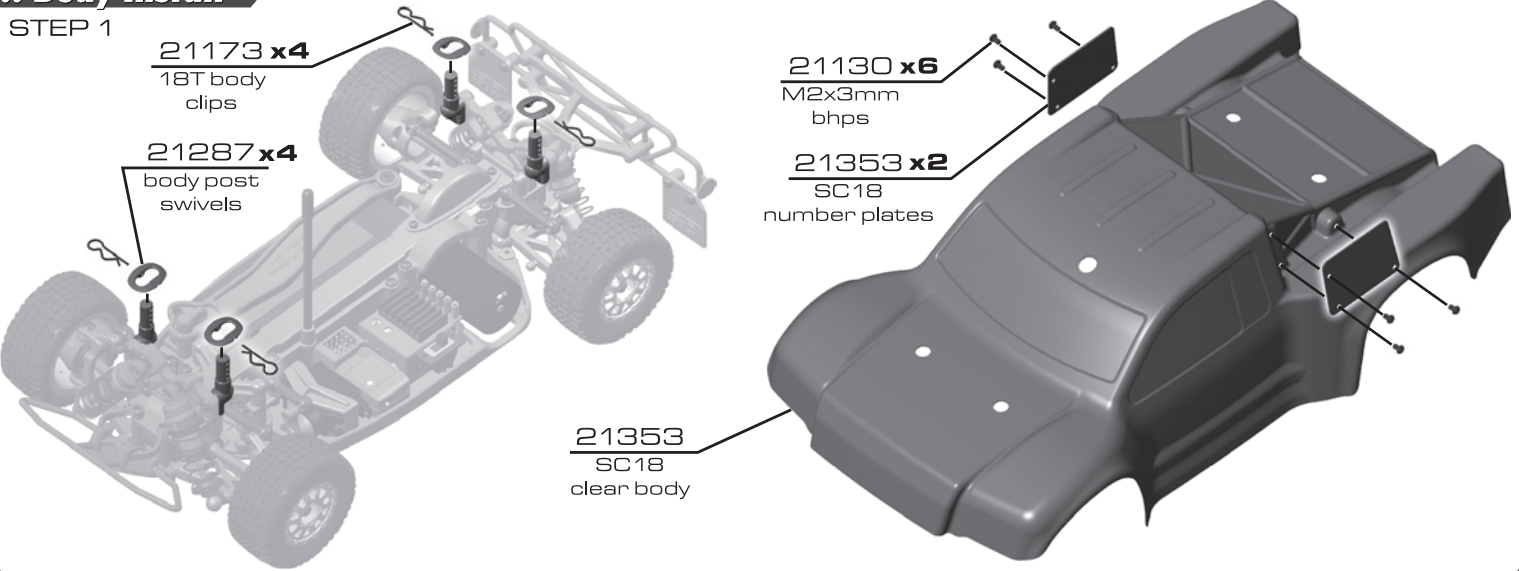

**:: Body Install (cont.)**

STEP 2

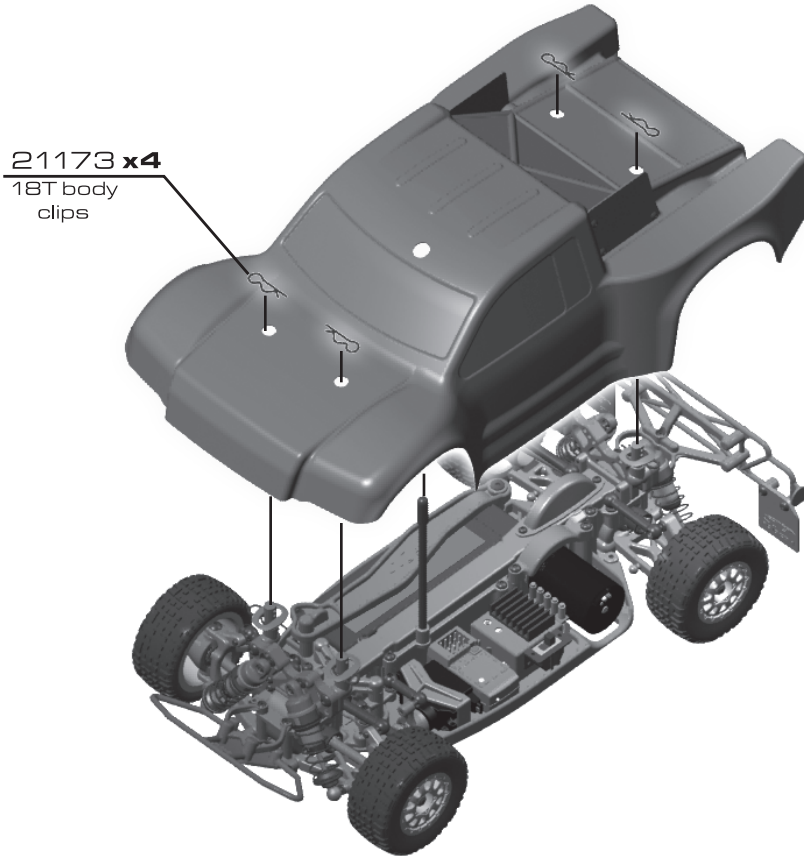

**:: Shocks**

21181 Shock Body, front, (fr & rr)	Pr.
21182 Shock Caps	4
21184 Shock Kit, front, (fr & rr)	Pr.
21189 Ballcaps, short	12
21191 Shock Accessories	Set
21192 Shock Rebuild Kit, rebuilds 4 shocks	Set
21197 Shock Spring, silver, 2.55 lb/in (Kit)	Pr.
21198 Shock Spring, blue, 3.0 lb/in (Kit)	Pr.
21199 Shock Spring, gold, 3.45 lb/in	Pr.

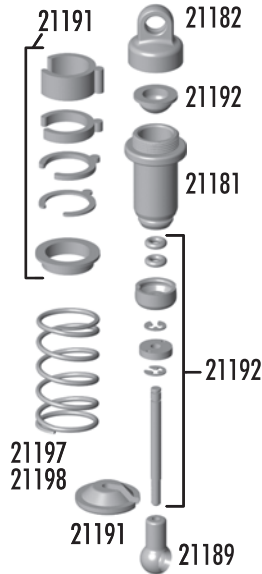

**:: Shock Oil**

5420 10 Weight Silicone Shock Oil	2oz.
5421 20 Weight Silicone Shock Oil	2oz.
5422 30 Weight Silicone Shock Oil	2oz.
5423 40 Weight Silicone Shock Oil	2oz.
5425 80 Weight Silicone Shock Oil	2oz.
5427 15 Weight Silicone Shock Oil	2oz.
5428 25 Weight Silicone Shock Oil	2oz.
5429 35 Weight Silicone Shock Oil	2oz.
5430 45 Weight Silicone Shock Oil	2oz.
5431 55 Weight Silicone Shock Oil	2oz.
5435 50 Weight Silicone Shock Oil	2oz.
5436 60 Weight Silicone Shock Oil	2oz.
5437 70 Weight Silicone Shock Oil	2oz.



**:: Gear Differential**

21106 Bearings, 8x12x3.5mm rubber sealed	Pr.
21135 M2x12mmFHPS	20
21141 Shim Set, .324x.409x.005	4
21317 Gear Diff Outdrives	2
21318 Gear Diff Case, Front (narrow)	Set
21319 Internal Diff Gears	Set
21335 Complete Gear Diff, Front	1
21406 Complete Gear Diff, Rear	1
21407 Gear Diff Case, Rear (wide)	Set

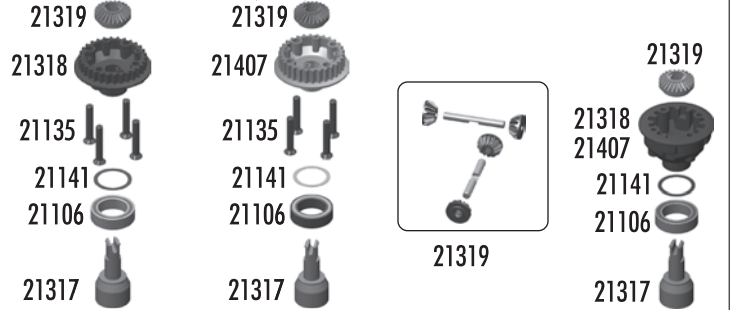

**:: Lubes and Adhesives**

1105 Green Slime Shock Lube	4cc
1596 FT Locking Compound	10ml
6588 Black Grease	4cc
6591 Diff Lube	4cc
6636 Silicone Grease	4cc
6727 Servo Tape Strips	2

