

Front Suspension

Steering
 Stop Gap: _____

Washers: _____
 Bumpsteer
 Washers: _____

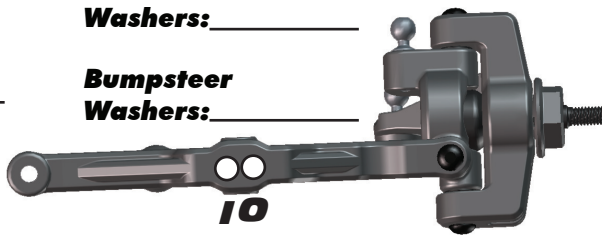

Anti Roll Bar:

1.5mm
 2.0mm
 2.2mm
 None



Universal
 CVA

Camber: _____

Toe: _____

Ride Height: _____

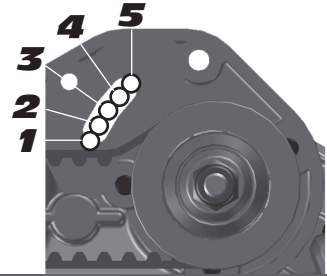

Washers: _____
 Front Pulley:
 20T (standard)
 19T (overdrive)
 Clicker:
 Full Time 4X4:

Rear Suspension

Wheelbase:
 Long
 Medium
 Short



Anti Roll Bar:

1.5mm
 2.0mm
 2.2mm
 None



Universal
 CVA

Camber: _____

Ride Height: _____

Toe Block: 3+2
 3+3

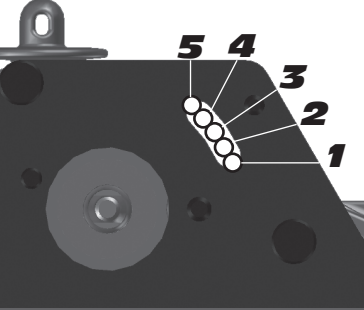

Washers: _____
 Rear Pulley:
 20T (standard)
 19T (underdrive)
 Slipper Pad Notes: _____

Front Shocks

Spring: _____ Piston: _____
 Shock Fluid: _____ Limiter: _____
 Rebound: _____ Bladder Emulsion

Rear Shocks

Spring: _____ Piston: _____
 Shock Fluid: _____ Limiter: _____
 Rebound: _____ Bladder Emulsion

Electronics

Motor & Wind: _____
 Pinion: _____
 Spur Gear: _____
 Batteries: _____
 Battery Placement: Front Middle Back
 Other

Radio: _____
 Throttle / Brake e.p.a: _____
 Throttle / Brake expo: _____
 Servo: _____ Steering Expo: _____
 ESC: _____
 ESC Profile: _____

Differentials

Front Diff Fluid: _____
 Rear Diff Fluid: _____

Other

Body Type: _____
 Body Notes: _____

Front Tires

Tire: _____ Compound: _____
 Insert: _____ Wheel: _____
 Notes: _____

Rear Tires

Tire: _____ Compound: _____
 Insert: _____ Wheel: _____
 Notes: _____

Race and Vehicle Comments

Qualify: _____ Main: _____ Finish: _____ TQ: _____
 Comments: _____

Track Info

Smooth: Bumpy: Blue Groove:
 Traction: High: Medium: Low:
 Soft Dirt: Grass: Clay: Wet:
 Dusty: Other: _____