

Front Suspension

Steering Rack
Standard
Option

Washers: 0

Bumpsteer

Washers: 2mm

Option Rack

Forward
Back

Anti Roll Bar:

1.5mm
1.8mm
2.0mm
2.2mm
None

Camber: -1

Toe: 2out

Ride Height: 23mm

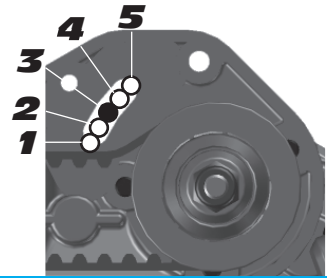

Washers: 1mm

Front Pulley:
20T (standard)
19T (overdrive)

Clicker:
Full Time 4X4:

Front Shocks

Spring: Yellow Piston: 1.2
Shock Fluid: 32 Limiter: 0, not unscrewed
Rebound: 0, with 8mm up travel limiters Bladder Emulsion

Electronics

Motor & Wind: ICON OR REEDY 4.0
Pinion: 11 Spur Gear: 62
Battery Type: Stick Saddle
Battery Placement: Front Middle Back
Other

Slipper / Differentials

Standard Slipper VTS Slipper
Front Diff Fluid: 20K
Rear Diff Fluid: 7K

Front Tires

Tire: BARCODES Compound: GOLD
Insert: STOCK Wheel: HAZARD
Notes: RAN IN THE STREET A BIT TO BREAK THEM IN

Body

Body Type: JC HIGHFLOW Notes: NOTHING CUT OUT

Race and Vehicle Comments

Qualify: 1 Main: 1 Finish: 1 TQ:
Comments: Buggy c Hub flipped upsidedown mounted to rear hub to raise the link

Rear Suspension

Reset Form

Wheelbase:
Long
Medium
Short

Anti Roll Bar:

1.5mm
1.8mm
2.0mm
2.2mm
None

Camber: -1

Ride Height: 23mm

Toe Block: 3-2
3-3

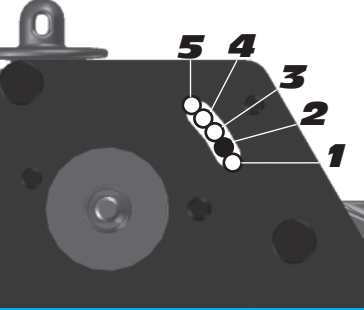

Washers: 7mm

Rear Pulley:
20T (standard)
19T (underdrive)

Slipper Coupled
Slipper De-Coupled

Rear Shocks

Spring: Yellow Piston: 1.2
Shock Fluid: 27.5 Limiter: 0, not unscrewed
Rebound: 0, with 8mm up travel limiters Bladder Emulsion

Radio: M11X
Throttle / Brake e.p.a: 100-80
Throttle / Brake expo: 0,0
Servo: XP 15 Steering Expo: 0
ESC: STOCKSPEC V2 ESC Software: NEWEST
ESC Profile: 0 --- 0 --- 1 --- 1

Chassis

Chassis Brace: Yes No
Chassis Weight: 30g on each side of servo, 60g total, With Alum screw kit and all option parts

Rear Tires

Tire: BARCODES Compound: GOLD
Insert: STOCK Wheel: HAZARD
Notes: RAN IN THE STREET A BIT TO BREAK THEM IN

Track Info

Smooth: Bumpy: Blue Groove:
Traction: High: Medium: Low:
Soft Dirt: Grass: Clay: Wet:
Dusty: Other: