

FACTORY TEAM SC10.2 SHORT COURSE

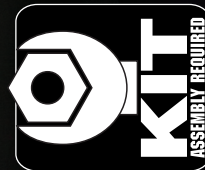

#7038 SC10.2 Factory Team Kit



1:10 Scale Electric 2WD Off Road Race Truck Kit Manual & Catalog ^{2/13}

TEAM ASSOCIATED



Designed in California, USA

:: Introduction

Thank you for purchasing this Team Associated product. This assembly manual contains instructions and tips for building and maintaining your new SC10.2. Please take a moment to read through this manual to help familiarize yourself with these steps.

We are continually changing and improving our designs; therefore, actual parts may appear slightly different than in the illustrations. New parts will be noted on supplementary sheets located in the appropriate parts bags. Check each bag for these sheets before you start to build.

:: KIT Features

Features in the SC10.2 Factory Team:

- Factory Team 12mm 'Big Bore' hard anodized aluminum threaded shocks with TiN "Gold" 3mm shock shafts
- VTS slipper (variable torque, multi-plate slipper with 3 drive surfaces) assembly featuring a high-resolution spring
- Factory Team 12mm blue aluminum front and rear clamping hexes with hex drive wheels
- "Gull-wing" front suspension arms and updated shock towers optimized for 12mm big bore shocks
- Factory Team 7075-T6 blue aluminum 0° rear hubs with oversized outer bearing
- Factory Team carbon fiber battery strap with locking thumb knobs
- CVA joints with pin retainer clips
- Ball differential with light-weight outrives
- Updated front and rear body mounts
- Complete set of precision ball bearings
- Factory Team blue titanium turnbuckles, blue aluminum hinge pin brace, milled motor plate, servo mounts, rear ballast weight and much more!

:: Additional

Your new SC10.2 FT kit comes unassembled and requires the following items for completion (refer to catalog section for suggestions):

- R/C two channel surface frequency radio system
- AA-size batteries for transmitter (#302 alkaline, #303 rechargeable)
- Electronic Speed Control, ESC (#29140, #29143)
- Steering servo (#29166, #29167) • R/C electric motor
- Pinion gear, size determined by type/wind of motor
- Battery charger (a peak detection charger, or LiPo compatible charger)
- 6 cell NiMH battery pack (#700) or a 2 cell LiPo battery pack (#714)

- Calipers or a precision ruler
- Needle nose pliers
- Polycarbonate specific spray paint
- Reamer / hole punch
- Cyanacrylate glue (#1597)
- Thread locking compound (#1596)
- Tires and Inserts, Fronts and Rears

Tools included:

- Allen wrenches #6950 (.050", 1/16", 3/32", 5/64")
- Molded tools #6956
- Camber gauge #1719

:: Other Helpful Items

- Silicone Shock Fluid (Refer to catalog for complete listings)
- Body Scissors (AE Part # 1737)
- FT Hex Wrenches (AE Part # 1655)
- Soldering Iron
- Reamer / Hole Punch
- Needle Nose Pliers
- Calipers or a Precision Ruler
- Wire Cutters
- Multi Tool (AE Part #7494)
- Green Slime shock lube (AE Part # 1105)
- Hobby Knife

Associated Electrics, Inc.
26021 Commercentre Dr.
Lake Forest, CA 92630



Customer Service
Tel: 949.544.7500
Fax: 949.544.7501

:: Table of Contents

1.....	Cover	16 - 18.....	Electronics Build (Bag H-HH)
2.....	Introduction	19.....	Wheels, Tires and Body Install (Bag I)
3.....	Table of Contents	20 - 21.....	Tuning Tips
4.....	Steering Build (Bag A-AA)	22 - 32.....	Catalog
4 - 5.....	Front End, Outer Build (Bag B-BB)	33 - 34.....	Notes
5 - 7.....	Front End, Inner Build (Bag C)	35.....	Setup Sheet "Kit Setup"
7 - 10.....	Transmission Build (Bag D-DD)	36.....	1:1 Hardware "Fold Out"
10 - 13.....	Rear End Build (Bag E-EE)	36.....	Servo Chart
13 - 14.....	CVA and Turnbuckle Build (Bag F-FF)	37.....	Setup Sheet "Blank"
14 - 16.....	Shocks Build (Bag G-GG)	38.....	Back Cover

:: Notes

This symbol indicates a special note or instruction in the manual.



There is a 1:1 hardware foldout page in the back of the manual. To check the size of a part, line up your hardware with the correct drawing until you find the exact size. Each part in the foldout has a number assigned to it for ordering replacement parts.

Associated Electrics, Inc.
26021 Commercentre Dr.
Lake Forest, CA 92630



Customer Service
Tel: 949.544.7500
Fax: 949.544.7501

<http://www.TeamAssociated.com> • <http://www.RC10.com> • http://twitter.com/Team_Associated • <http://bit.ly/AEonFacebook>

:: Steering Build - Bag A-AA - Step 1

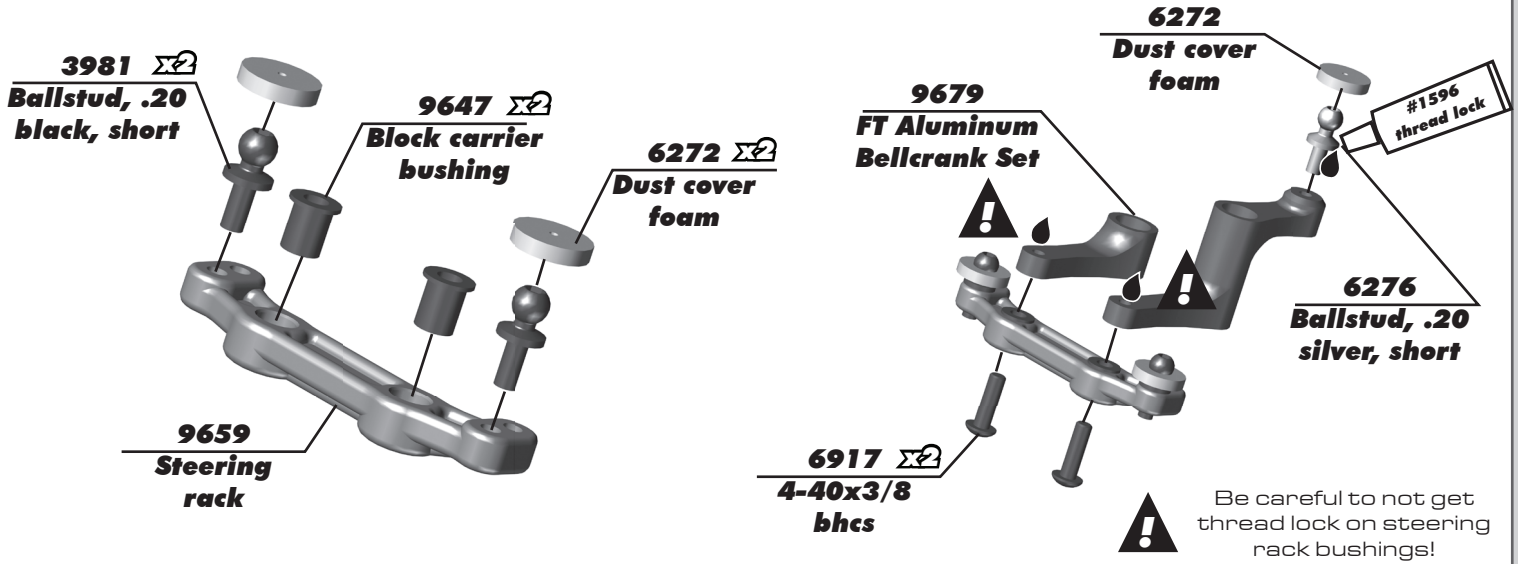

:: Steering Build - Bag A-AA - Step 2

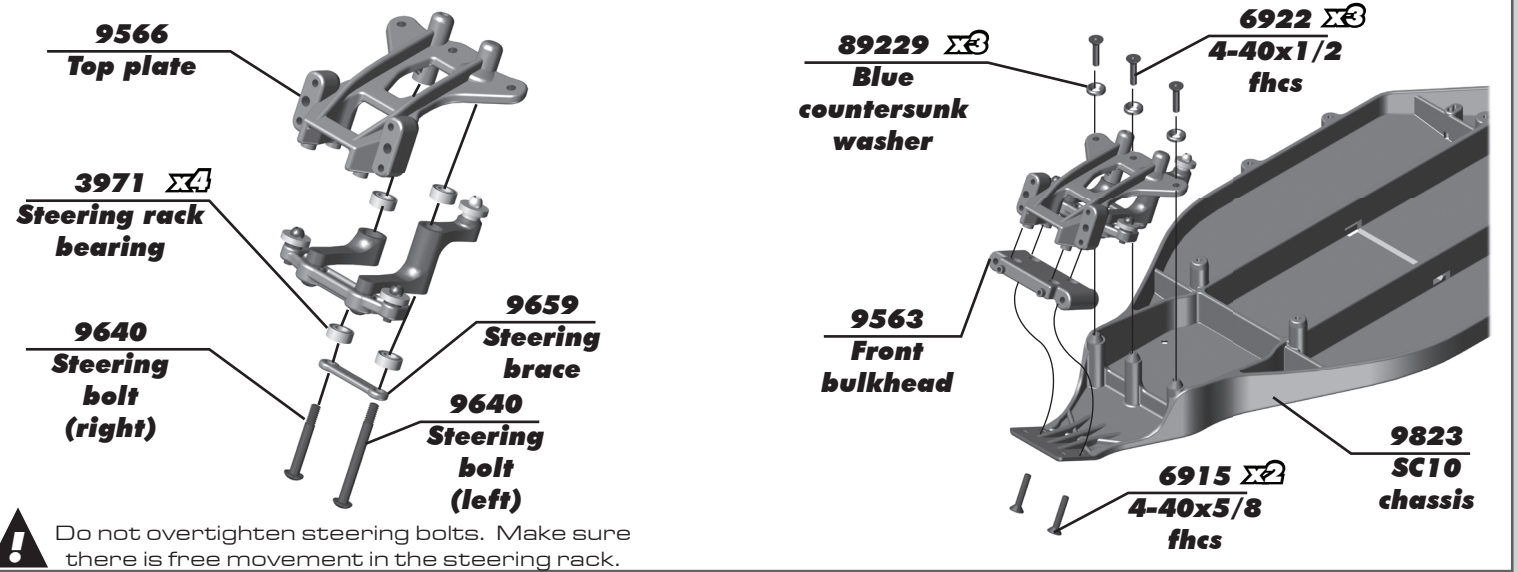

:: Front End, Outer Build - Bag B-BB - Step 1

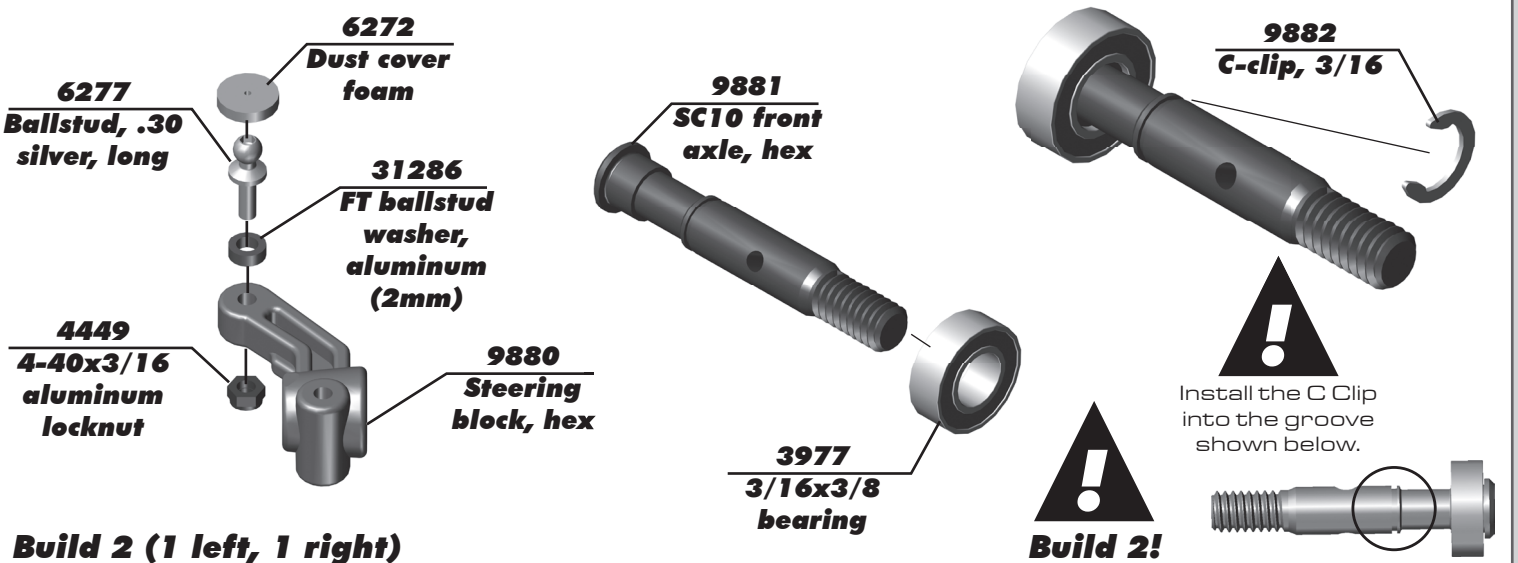

:: Front End, Outer Build - Bag B-BB - Step 2

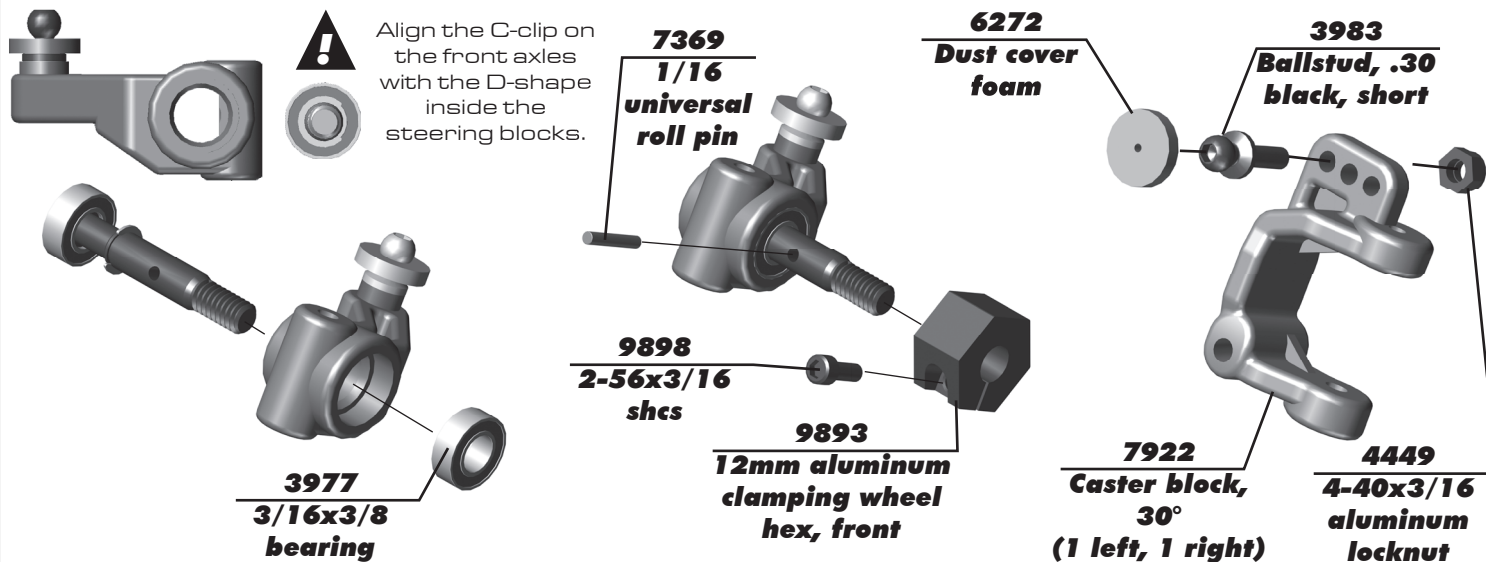

:: Front End, Outer Build - Bag B-BB - Step 3

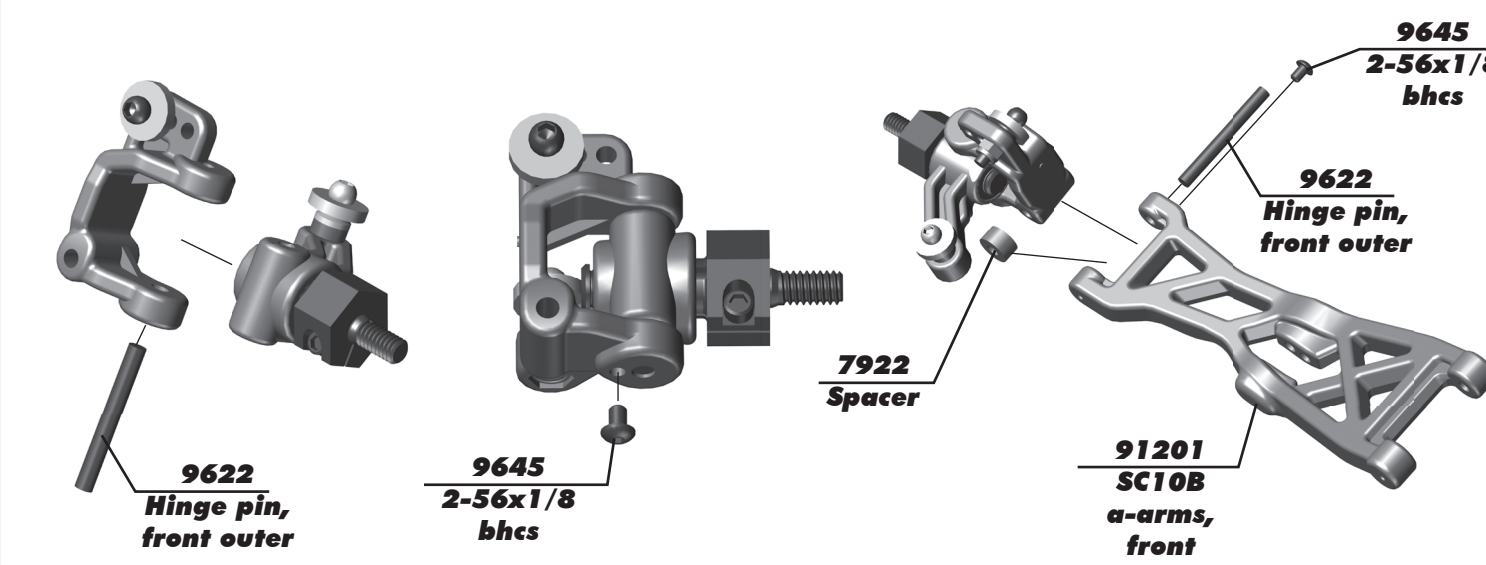

:: Front End, Inner Build - Bag C - Step 1

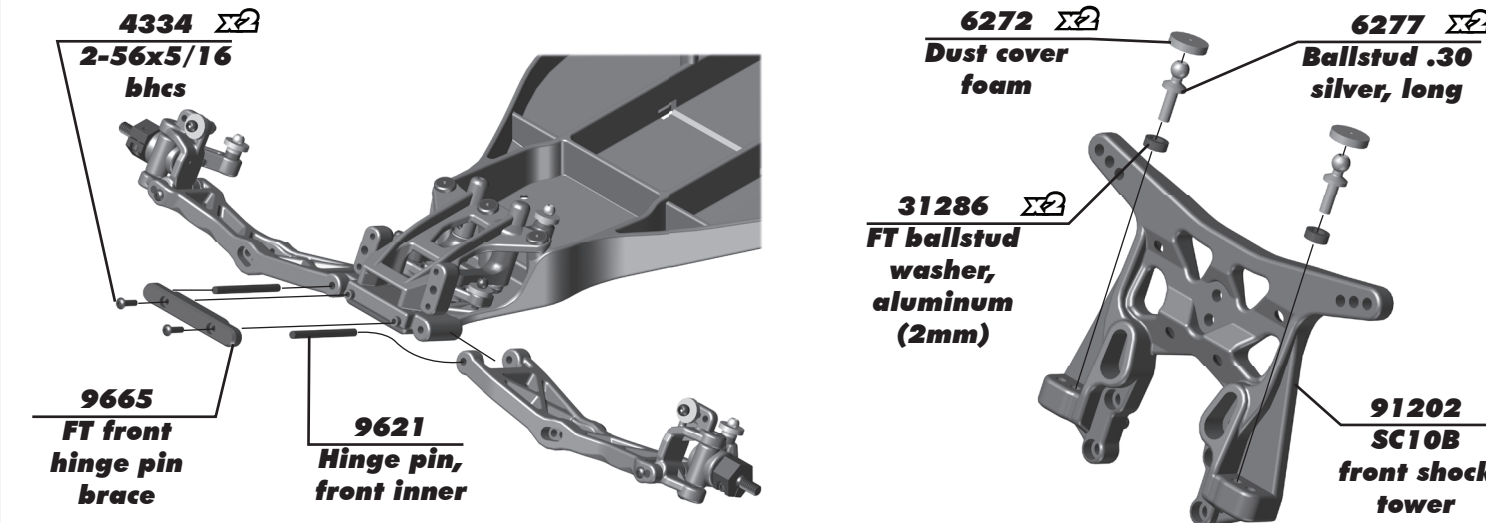

:: Front End, Inner Build - Bag C - Step 2

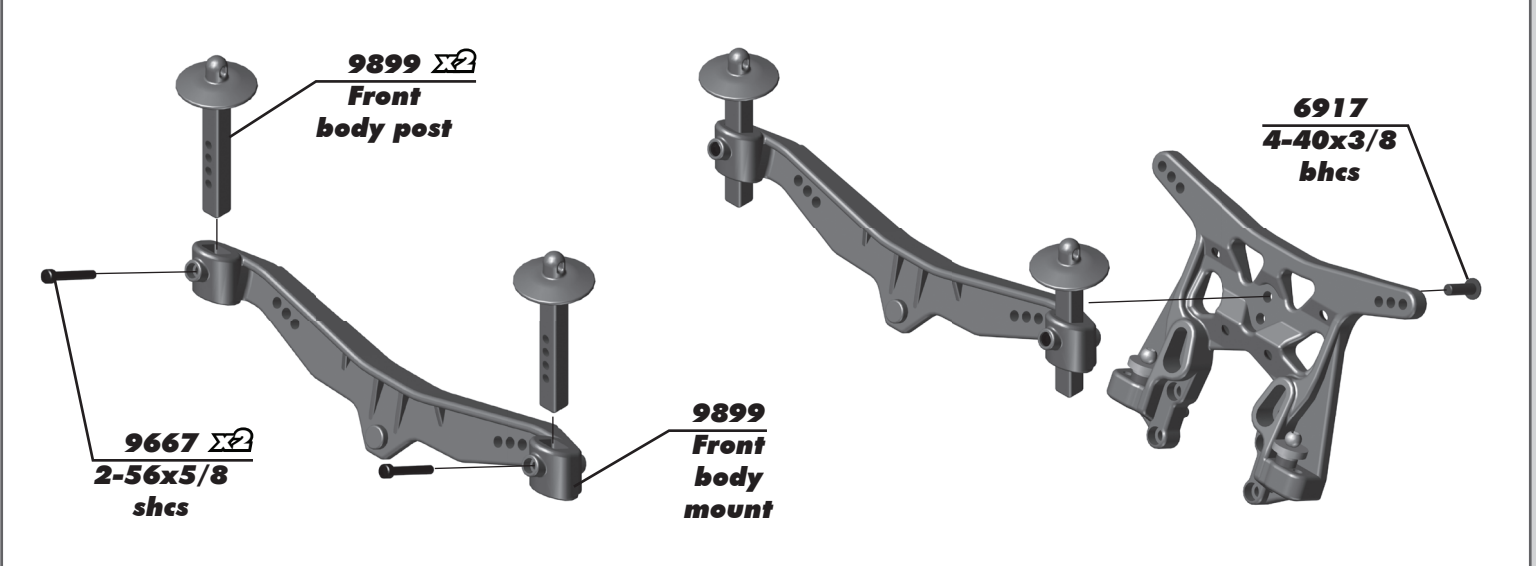

:: Front End, Inner Build - Bag C - Step 3

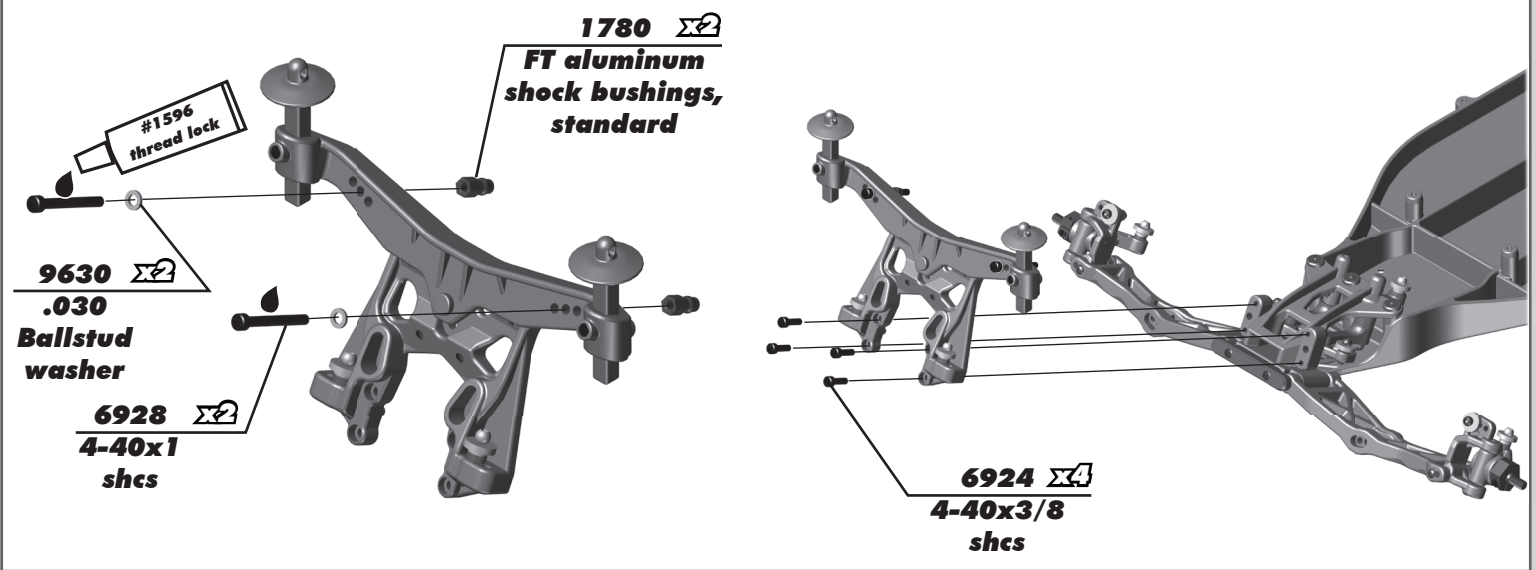

:: Front End, Inner Build - Bag C - Step 4

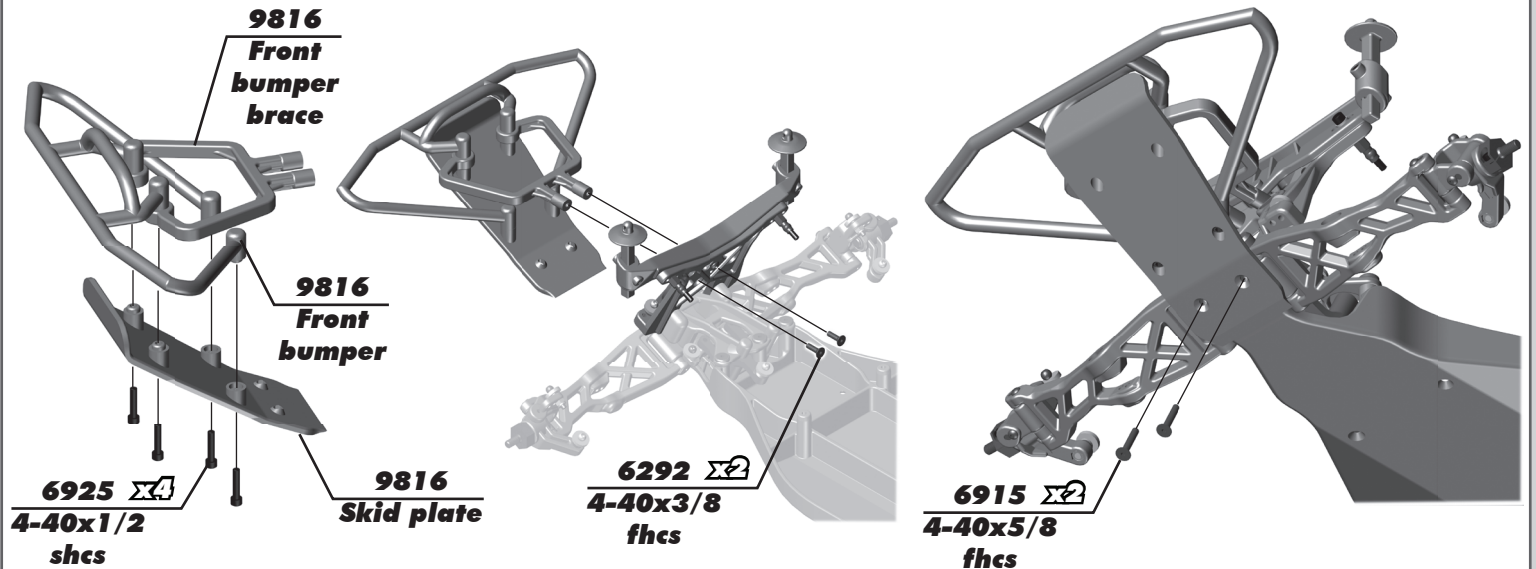

:: Front End, Inner Build - Bag C - Step 5

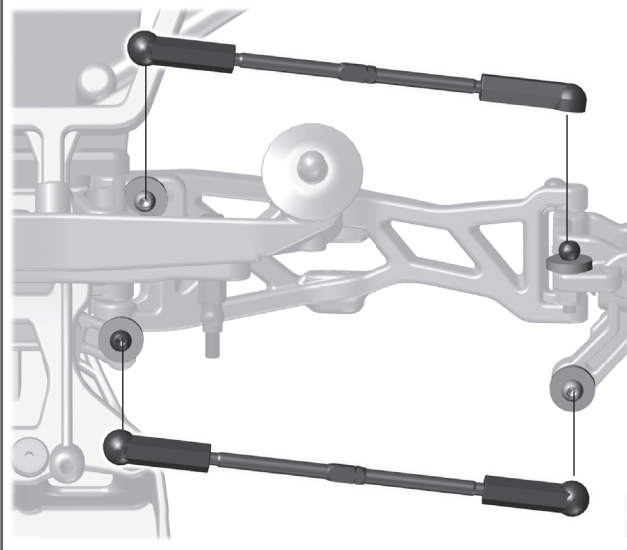

!
Orient the notch to the left throughout the car. It indicates which end has the left hand threads!

**Front Camber Turnbuckle
1.92" (48.75mm)**

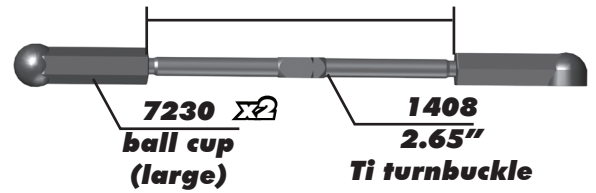

**Steering Turnbuckle
2.07" (52.75mm)**

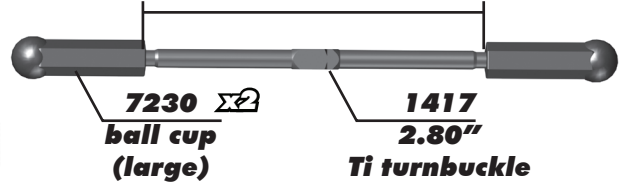

:: Front End, Inner Build - Bag C - Step 6

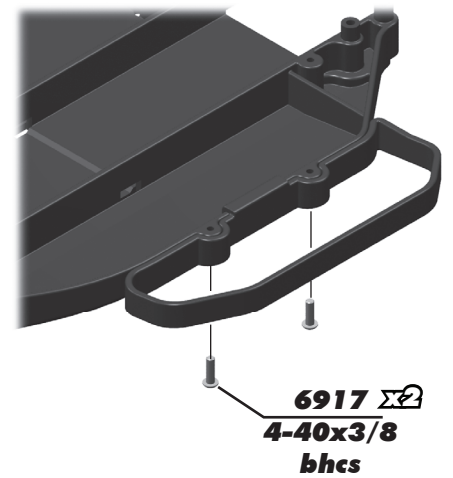
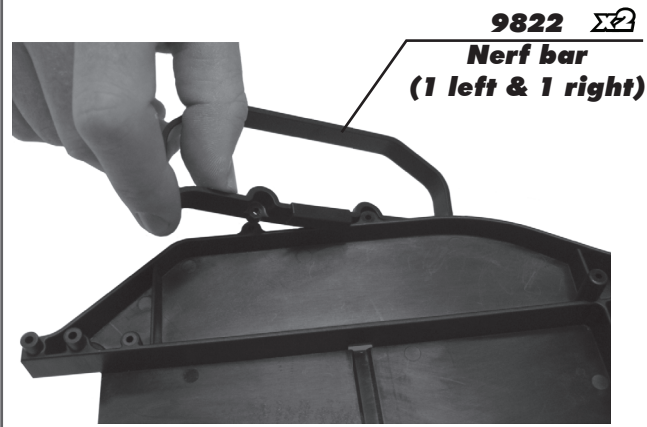

:: Transmission Build - Bag D-DD - Step 1

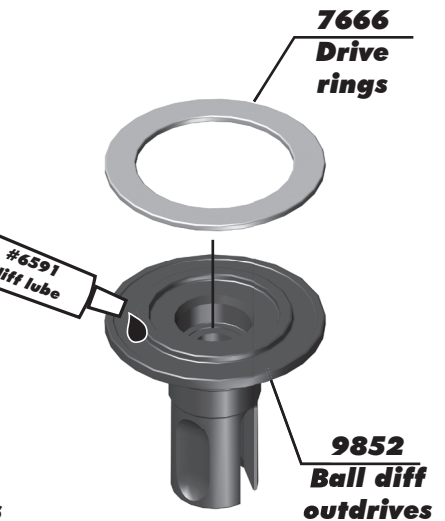
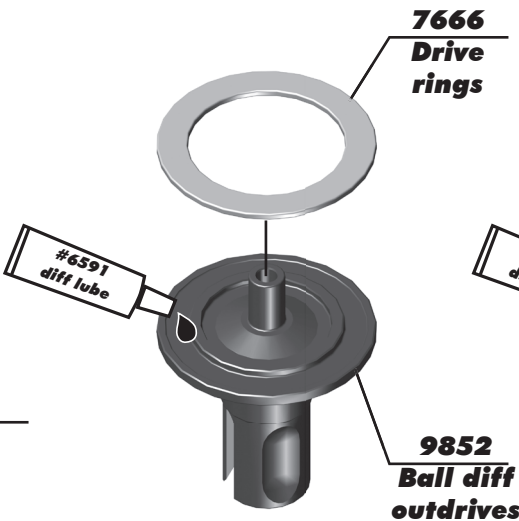
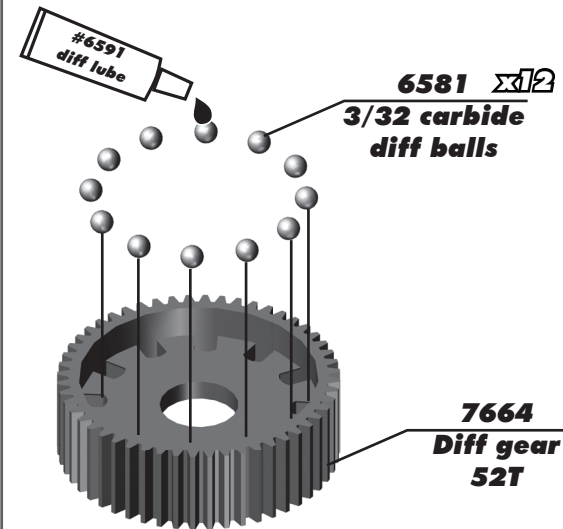

:: Transmission Build - Bag D-DD - Step 2



:: Transmission Build - Bag D-DD - Step 3

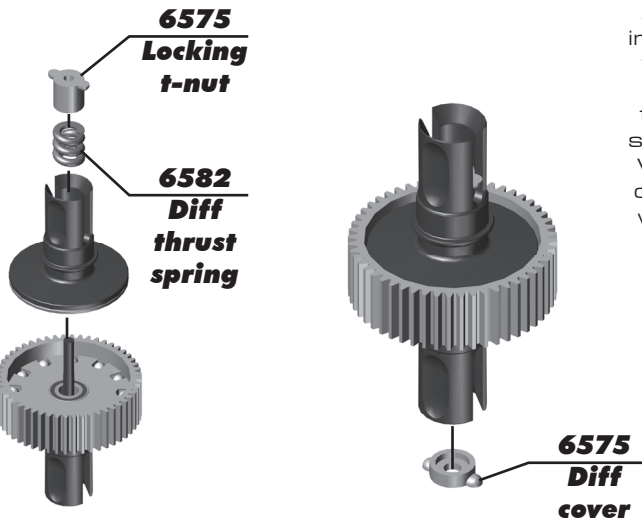

As you tighten the diff bolt, you will notice the T-nut ears moving closer to the bottom of the outdrive slot. This compresses the spring behind the T-nut. The spring should be completely compressed at the same time the T-nut reaches the end of the slot. Caution! Pay close attention to the feeling when the spring is completely compressed. Do not overtighten the bolt. When you feel the spring completely compressed, loosen the diff bolt 1/8" of a turn. Your diff should now operate smoothly with resistance as the outdrives move in opposite directions. After you have driven the car once, re-check the diff setting.

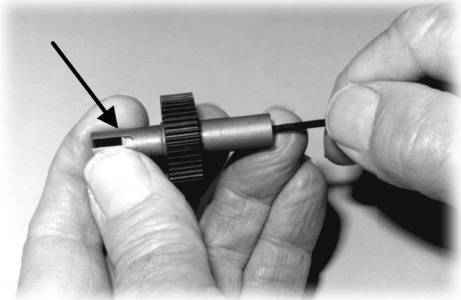

:: Transmission Build - Bag D-DD - Step 4

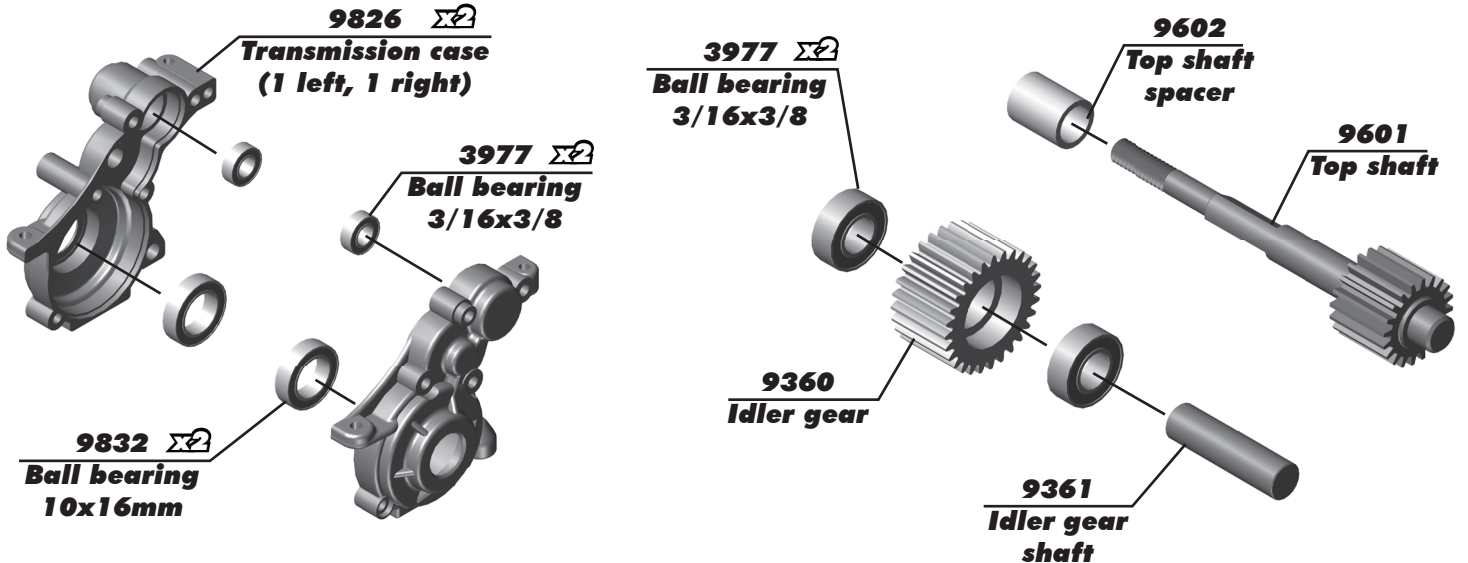

:: Transmission Build - Bag D-DD - Step 5

Install the Diff with the head of the Diff Thrust Bolt (#6573) facing the right side of the transmission case!

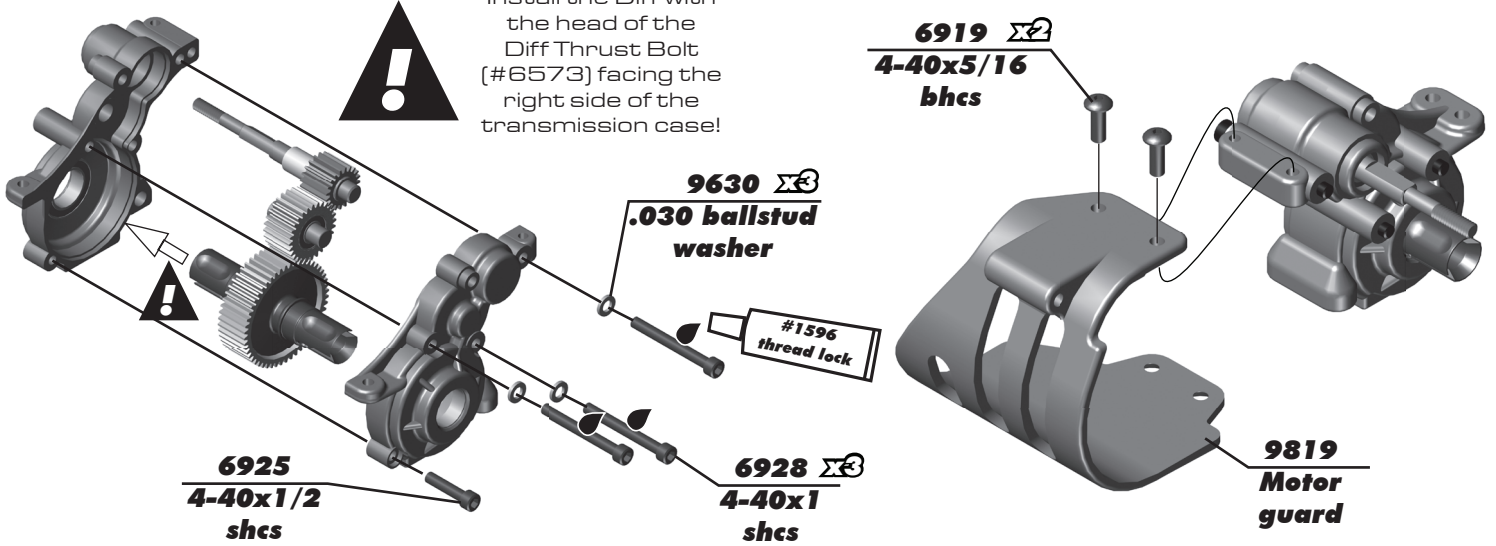

:: Transmission Build - Bag D-DD - Step 6

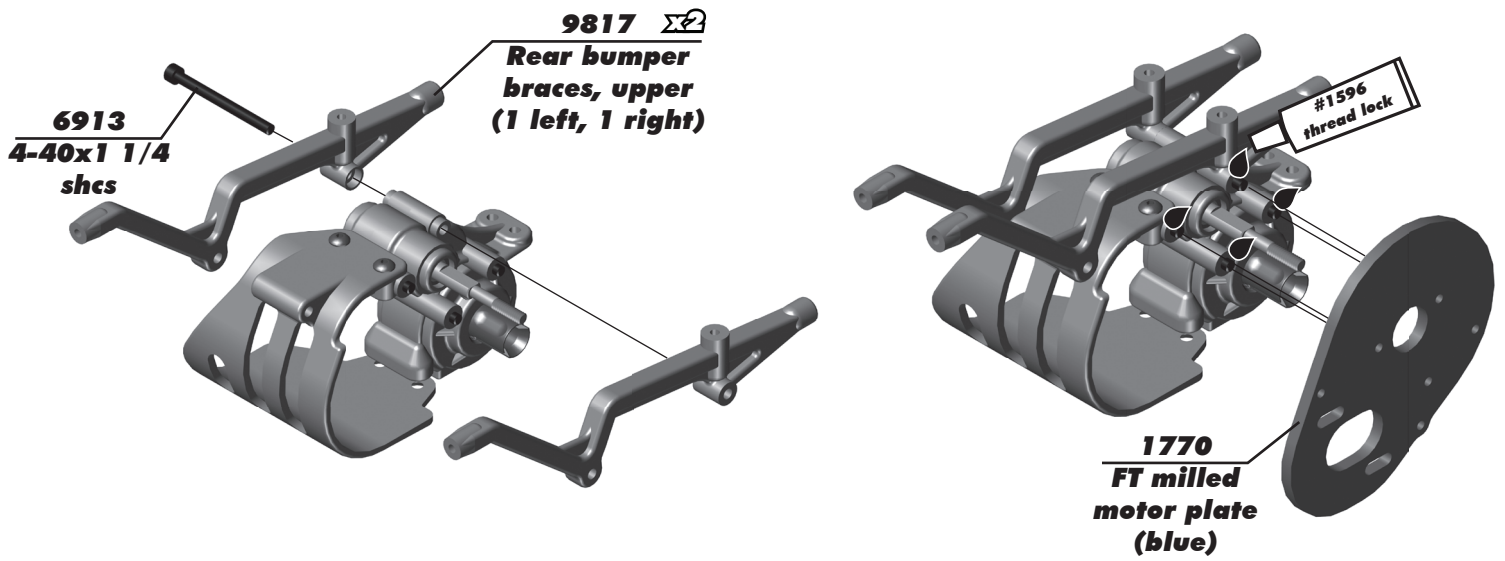

:: Transmission Build - Bag D-DD - Step 7

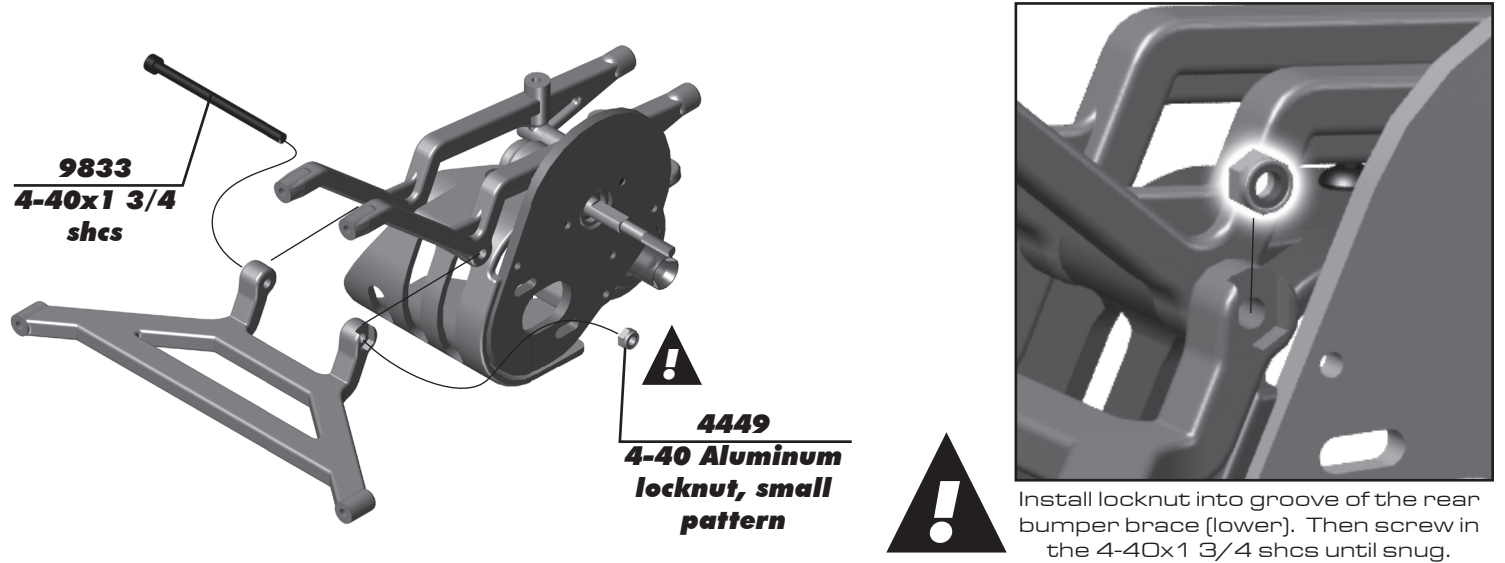

:: Transmission Build - Bag D-DD - Step 8

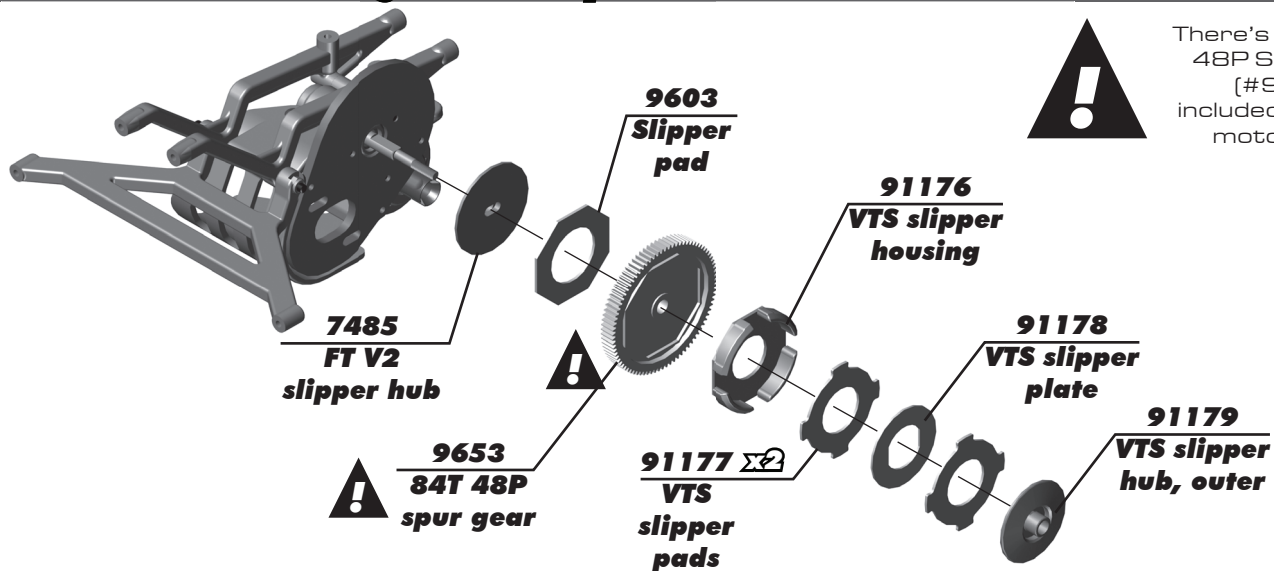

There's also a 75T 48P Spur Gear (#9650) included for stock motors use!

:: Transmission Build - Bag D-DD - Step 9

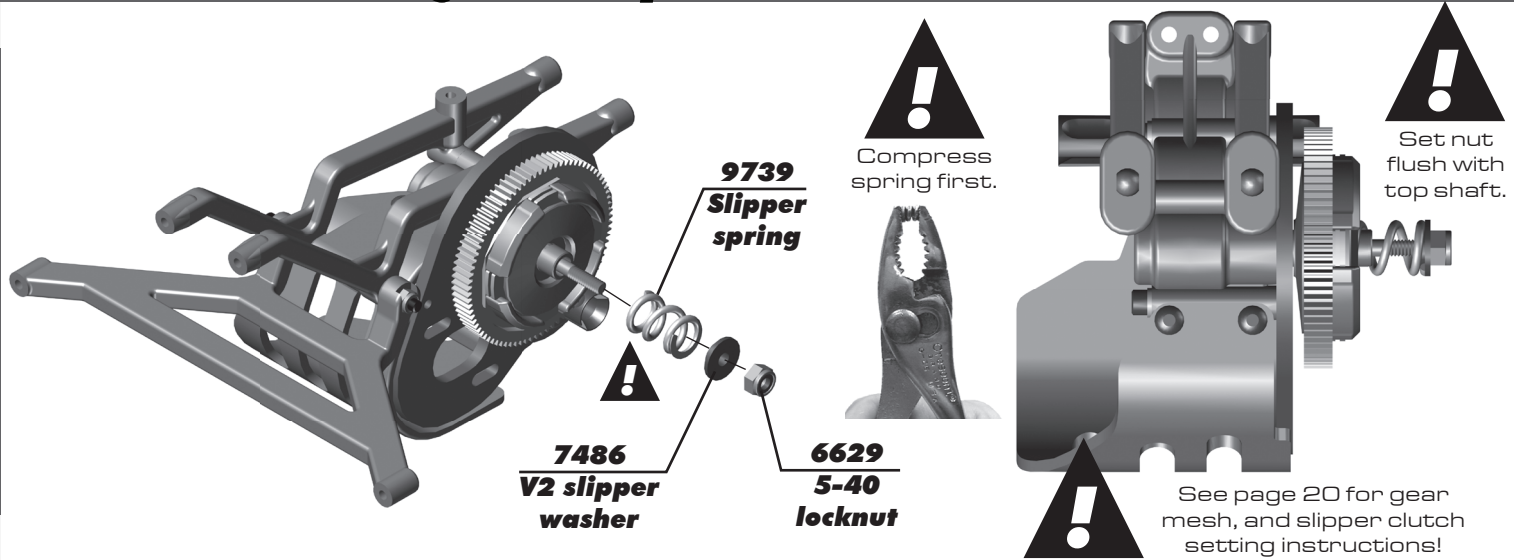

Compress spring first.



Set nut flush with top shaft.



See page 20 for gear mesh, and slipper clutch setting instructions!

:: Rear End Build - Bag E-EE - Step 1

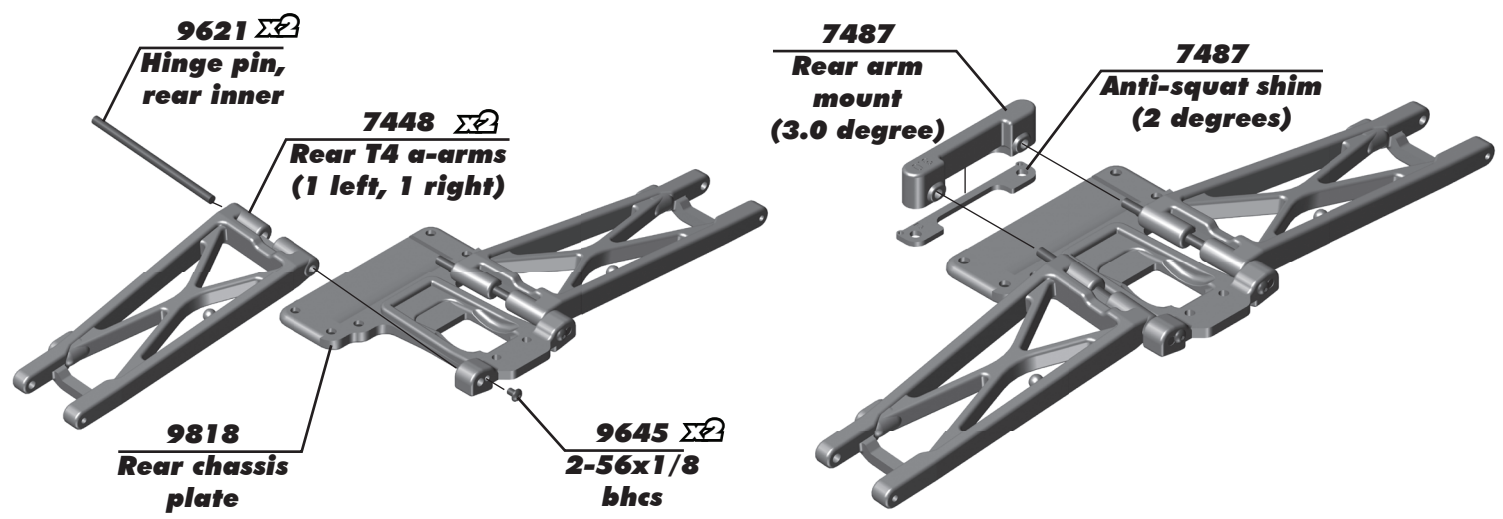

:: Rear End Build - Bag E-EE - Step 2

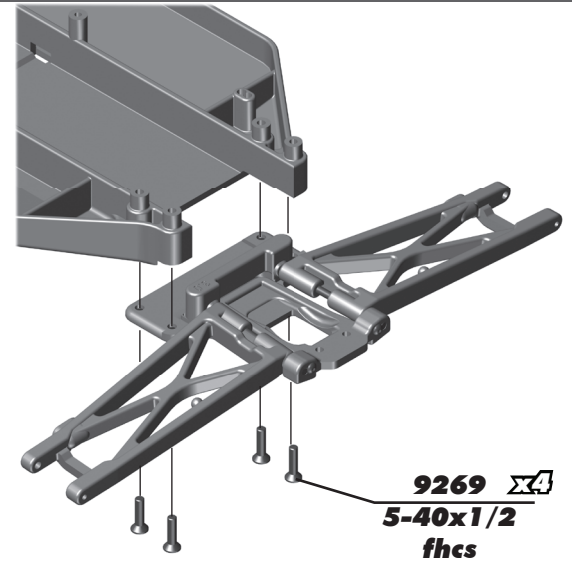
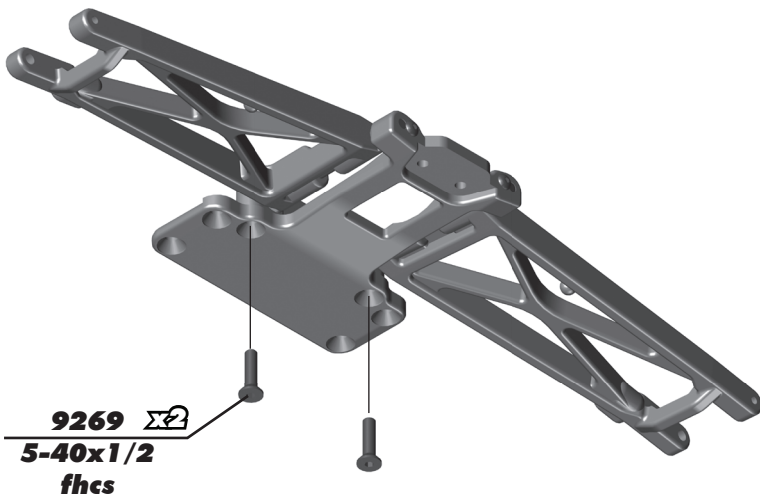

:: Rear End Build - Bag E-EE - Step 3

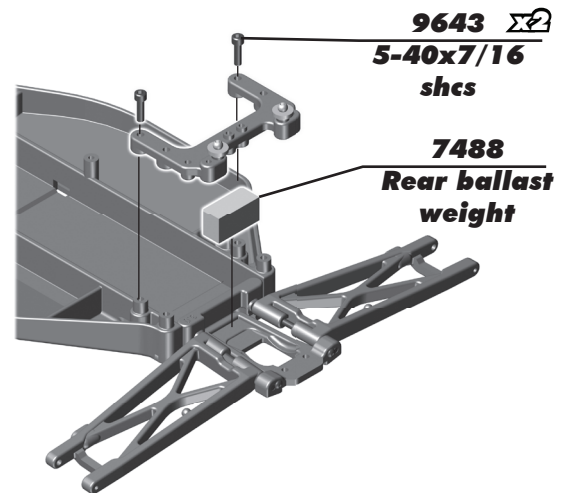
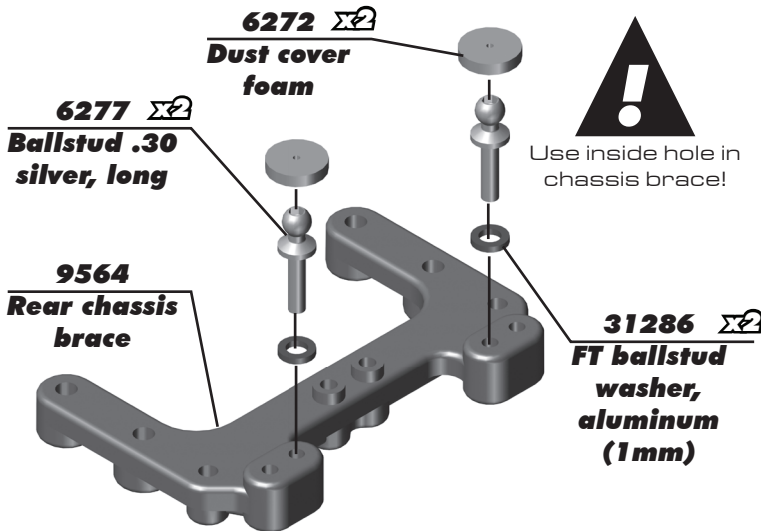

:: Rear End Build - Bag E-EE - Step 4

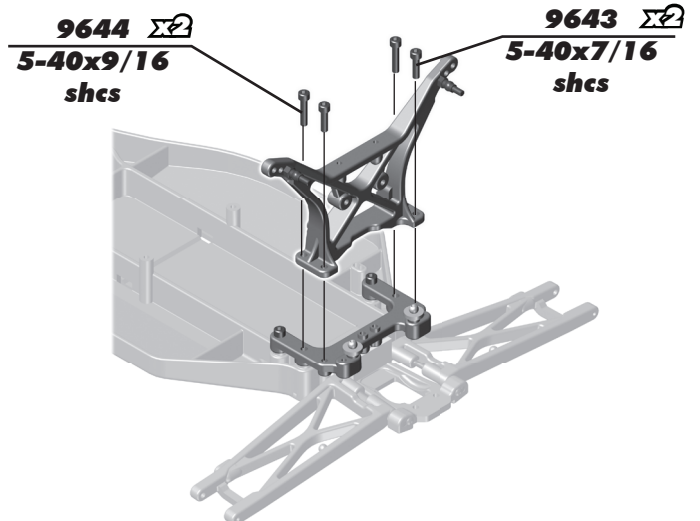
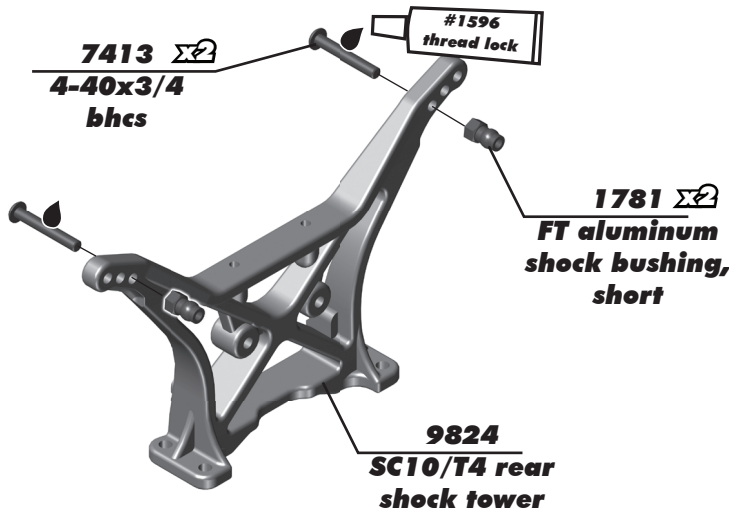

:: Rear End Build - Bag E-EE - Step 5

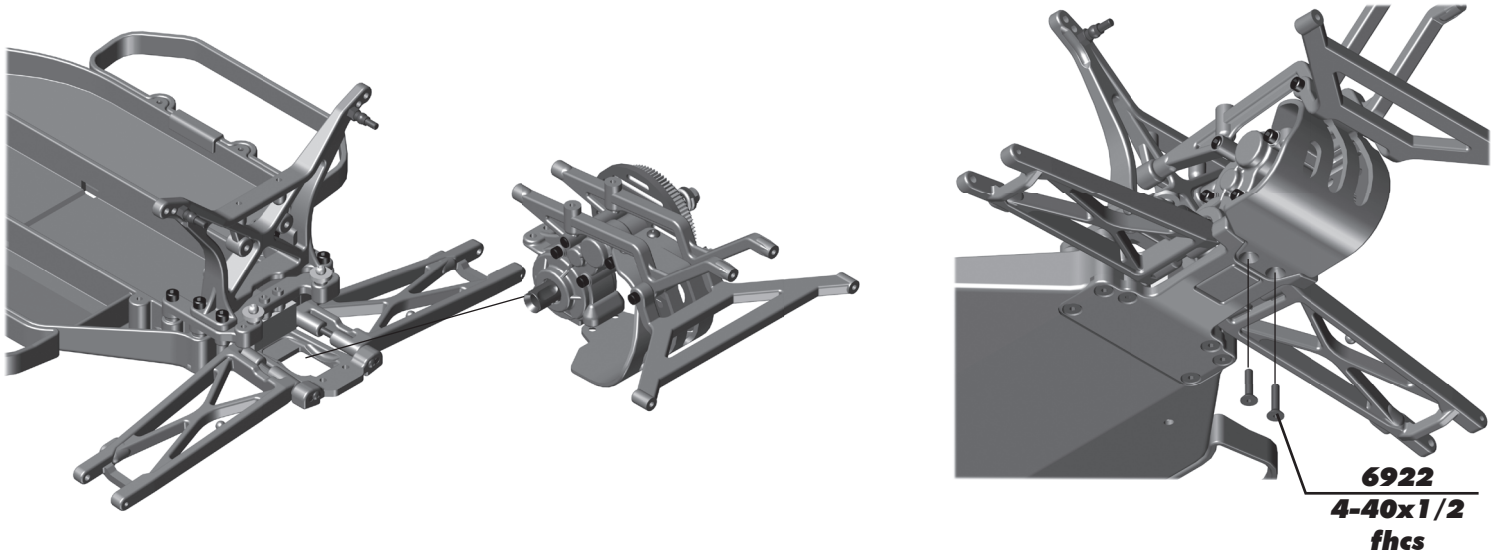

:: Rear End Build - Bag E-EE - Step 6

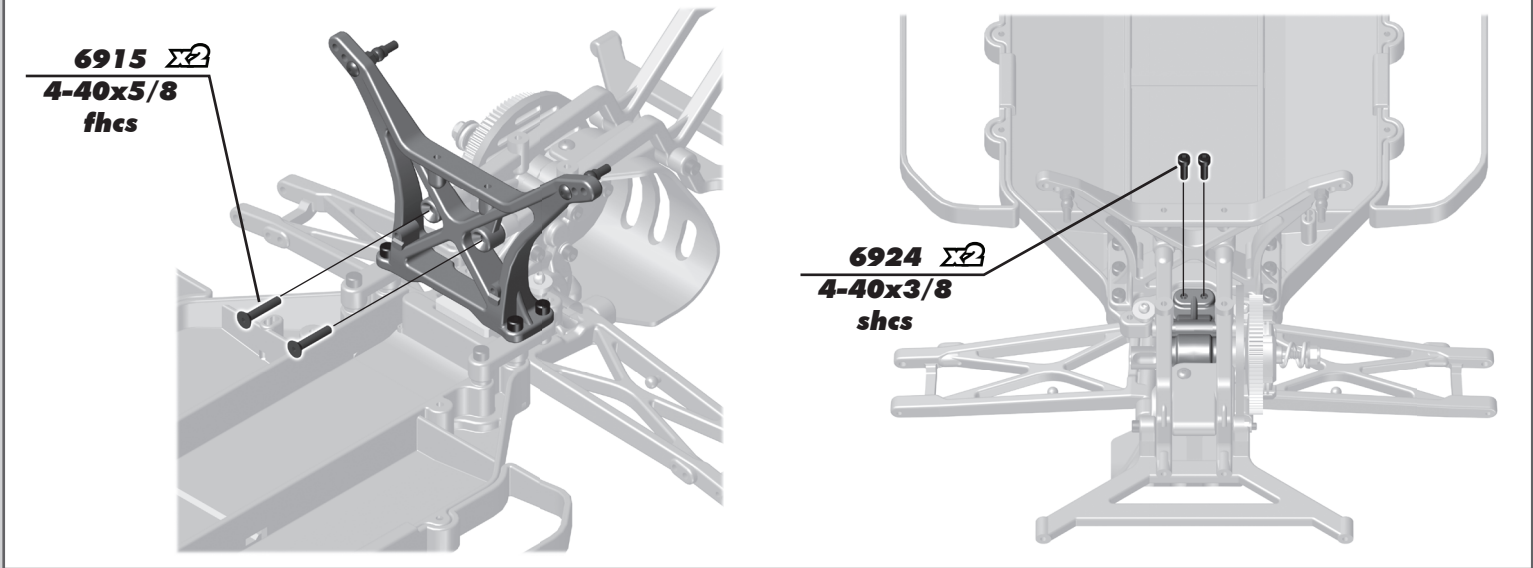

:: Rear End Build - Bag E-EE - Step 7

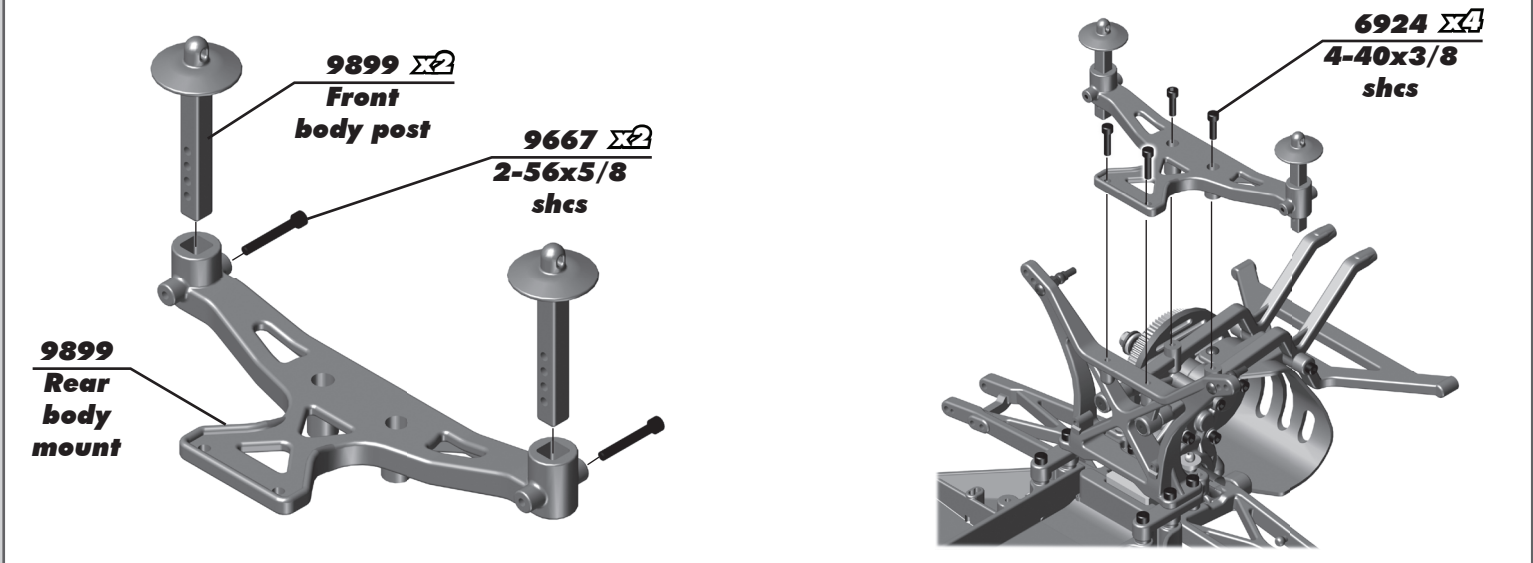

:: Rear End Build - Bag E-EE - Step 8

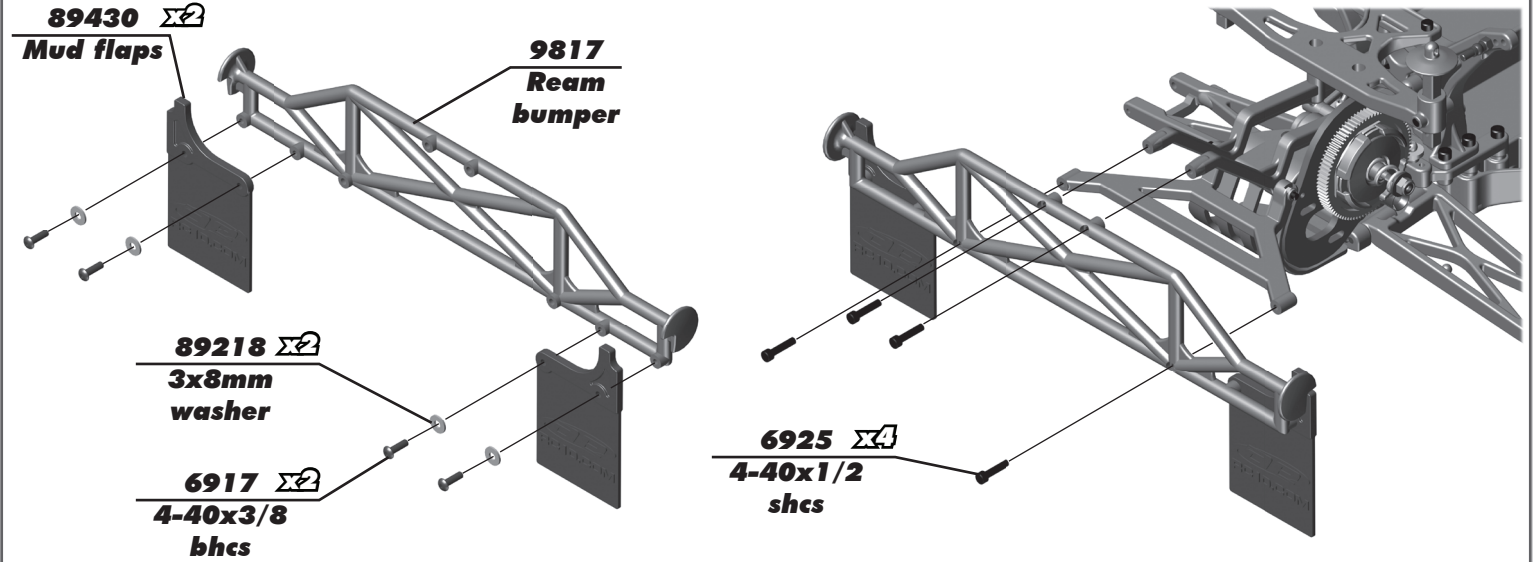

:: CVA and Turnbuckles Build - Bag F-FF - Step 1

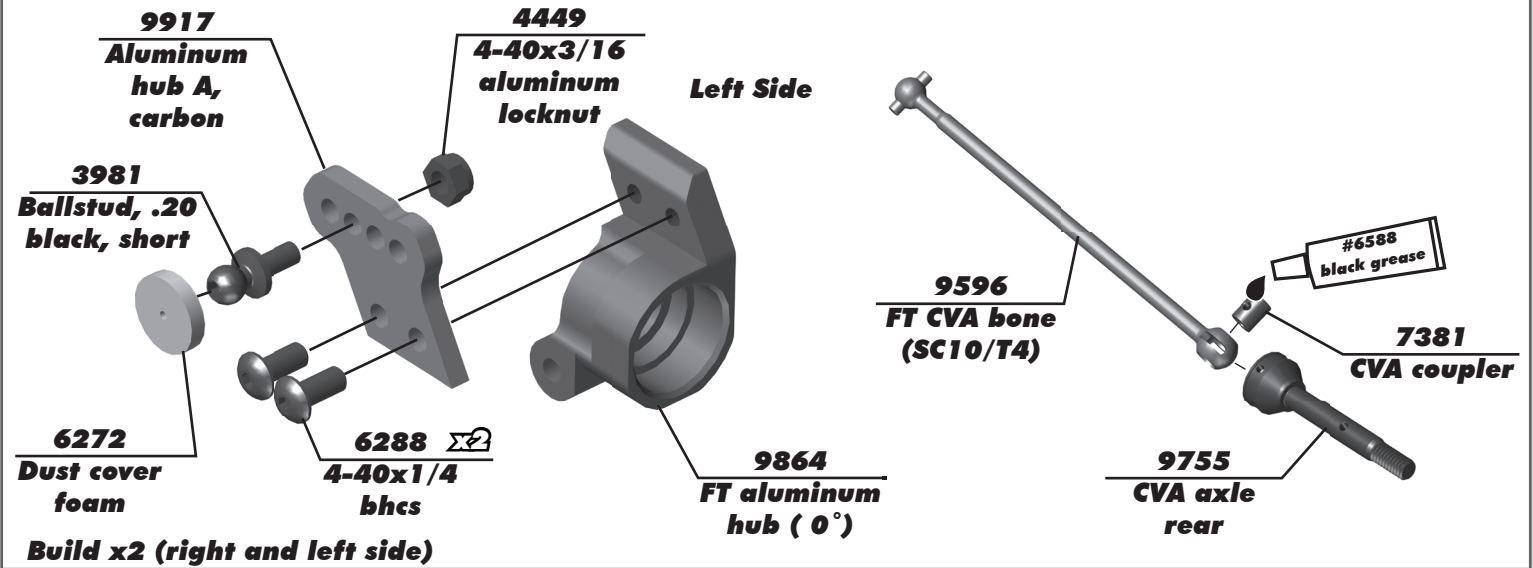

:: CVA and Turnbuckles Build - Bag F-FF - Step 2

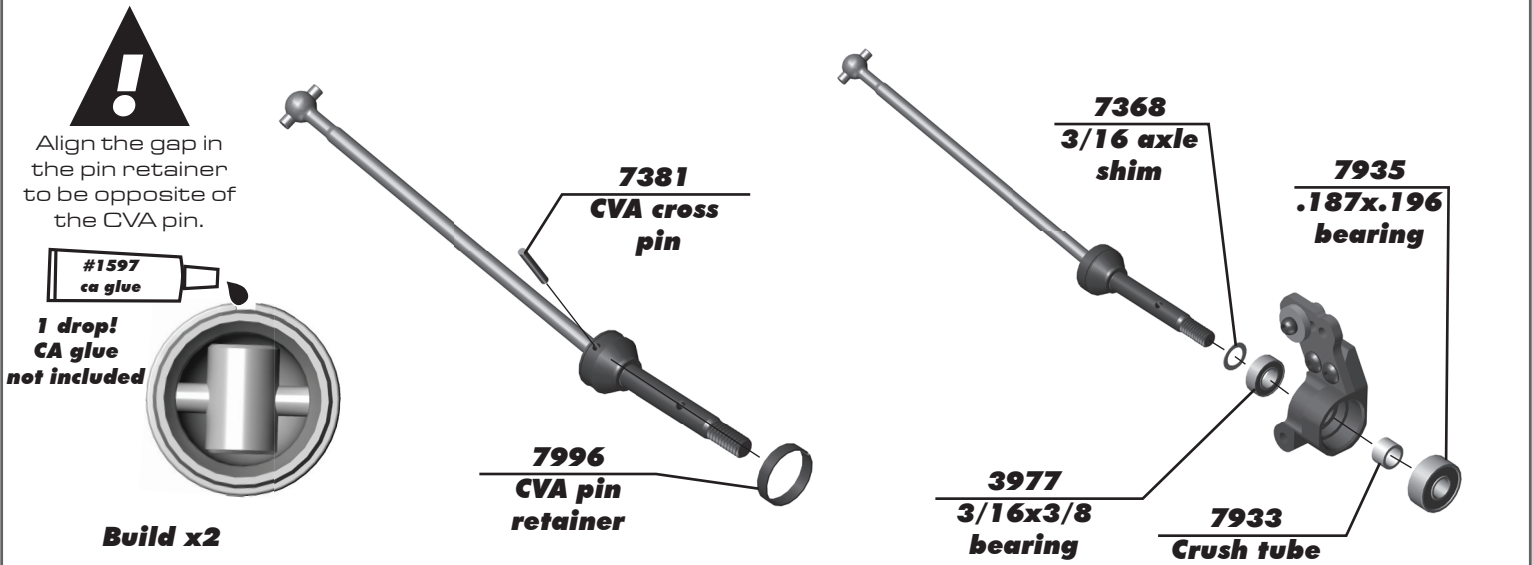

:: CVA and Turnbuckles Build - Bag F-FF - Step 3

7369
1/16
roll pins

9892
12mm aluminum
clamping wheel
hex, rear

9898
2-56x3/16
shcs

Build x2 (right and left side)

Build x2 (right and left side)

31286
FT ballstud
washer,
aluminum
(1mm)

9645
2-56x1/8
bhcs

9622
Hinge pin,
rear outer

9630
.030 ballstud
washer

:: CVA and Turnbuckles Build - Bag F-FF - Step 4

Steering Turnbuckle
2.10" (53.5mm)

7230 **ball cup (large)**

1417
2.80"
Ti turnbuckle

!
Orient the notch to the left throughout the car. It indicates which end has the left hand threads!

Build x2 (right and left side)

:: Shocks Build - Bag G-GG - Step 1

91308
12mm shock
piston
(1.6 front)
(1.7 rear)

6299
1/8 E-clip

91306
27.5x3 TiN
shock shaft
(front)

91307
35x3 TiN
shock shaft
(rear)

!
Racers Tip:
Use a marker over the numbers on the pistons to make them easily visible!

6299
1/8 E-clip

4187
Nylon spacer,
(.030)
Front:
4 spacers
Rear:
2 spacers

:: Shocks Build - Bag G-GG - Step 2

91300
12x27.5mm shock bodies (front)

91302
12x36mm shock bodies (rear)

5407 $\times 2$
O-ring

91309
Shock spacer

91309 $\times 2$
Shock hat bushing

91309
12mm shock cap o-ring

31327
VCS3 shock bottom cap o-ring

31327
VCS3 shock bottom cap

Racers Tip:
Lightly rub shock oil on the o-ring before installation!

Racers Tip:
Coating the o-rings with green slime (#1105) helps seal & reduce o-ring swell!
Green slime "not included in kit!"

#1105 green slime

1777
Shock eyelet

1777
FT shock pivot ball

:: Shocks Build - Bag G-GG - Step 3

Shock oil #5429

Front Shock: 35 wt

Rear Shock: 35 wt

91303 $\times 4$
12mm shock cap

Shock Bleeding Steps:

1. Pull shock shaft down.
2. Fill shock body 3/4 full with silicone shock fluid.
3. Slowly move the shock shaft up and down to remove air from under the piston.
4. Wait for bubbles to come to surface.
5. Fill shock body to top with silicone shock fluid.
6. Place a drop of oil in the cap and on cap threads.
7. Install cap (without bleed screw) and tighten completely.
8. Slowly compress shaft all the way to bleed excess silicone shock fluid out the hole in the cap (use rag around shock to catch excess fluid).
9. Install M2x4mm button head screw until snug while shaft is fully compressed.

91309 $\times 4$
Shock cap o-ring

31510 $\times 4$
M2x4mm bhcs

Step 1-2 **Step 3-4** **Step 5-6** **Step 7** **Step 8-9**

:: Shocks Build - Bag G-GG - Step 4

91304 $\times 4$
12mm threaded collar o-ring

91304 $\times 4$
12mm threaded collar

Racers Tip:
Use your finger to rub shock oil on the o-ring for smoother adjustment!

91329
12mm front spring, Gray (3.45lb)

91337
12mm rear spring, White (2.10lb)

91310
12mm shock spring cup (9mm offset)

Front: 7mm

Rear: 8.5mm

Build x2 front and x2 rear shocks

:: Shocks Build - Bag G-GG - Step 5

!
Use outside hole in front arm!

6927 $\Sigma 2$
4-40x3/4 shcs

6472 $\Sigma 2$
Shock mount nut

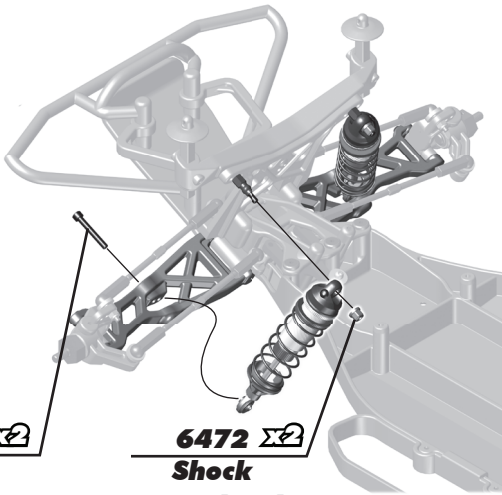

!
Use inside hole in rear arm!

6472 $\Sigma 2$
Shock mount nut

6925 $\Sigma 2$
4-40x1/2 shcs

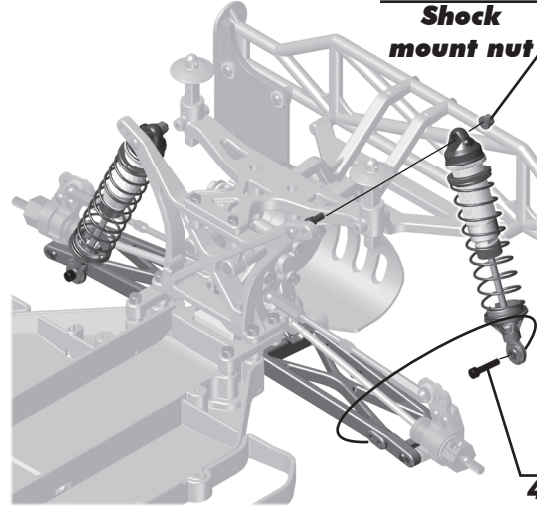

:: Electronics Build - Bag H-HH - Step 1

3981
Ballstud, .20 black, short

6272
Dust cover foam

Servo not included!

!

Offset the servo horn by 5-10 degrees (approximately one notch)

1779 $\Sigma 2$
FT Servo mount

6917 $\Sigma 2$
4-40x3/8 bhcs

7336 $\Sigma 2$
Servo spacers

Servo screw not included!
9180
Servo horn

89007
Servo horn ring

!

See page 36 for correct servo horn and spacing on the servo chart!

7337 $\times 4$
Gold washer

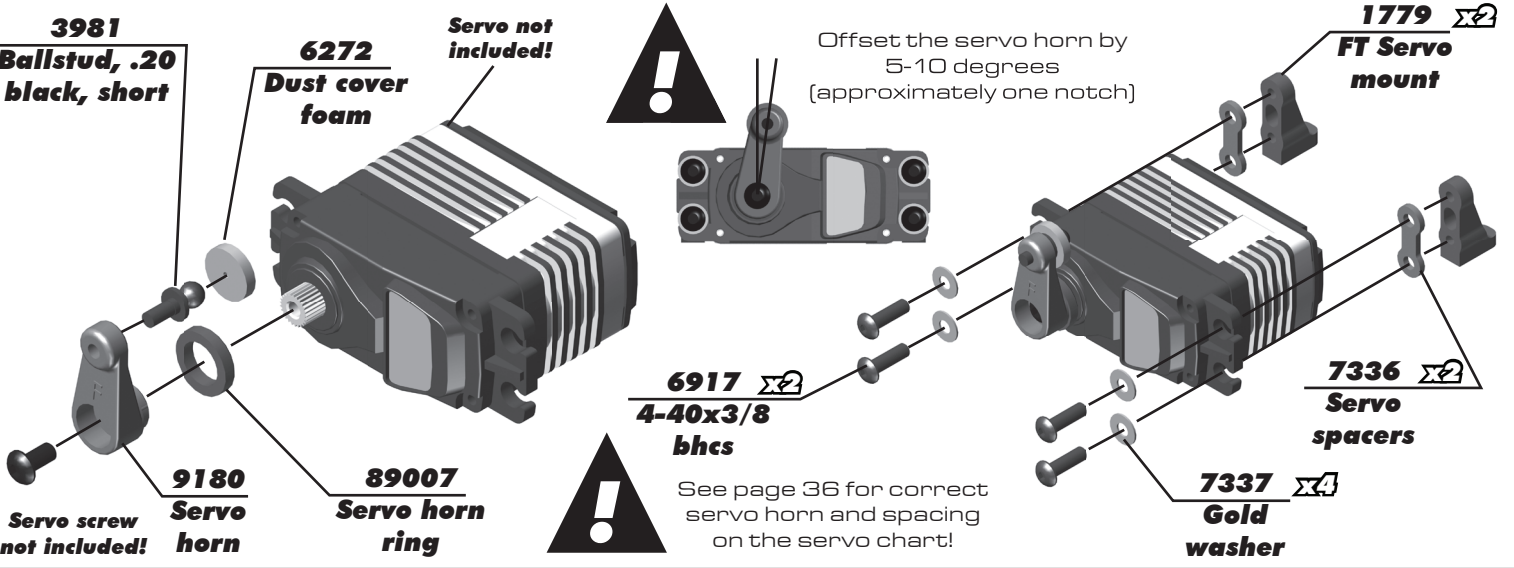

:: Electronics Build - Bag H-HH - Step 2

9170
Servo link

!

Leave a 2mm gap!

6292 $\Sigma 2$
4-40x3/8 fhcs

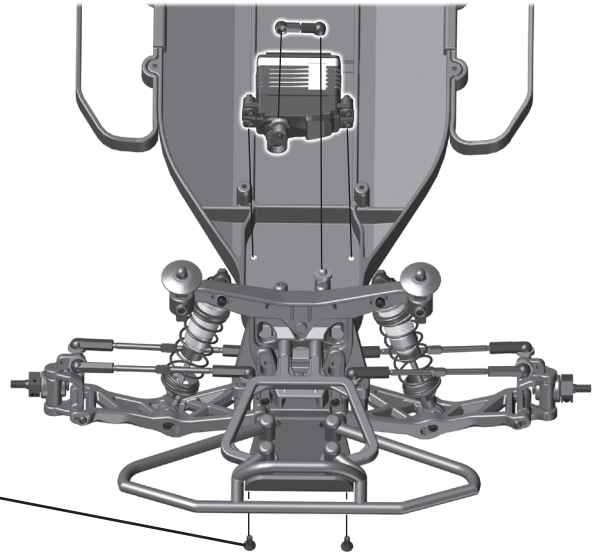

:: Electronics Build - Bag H-HH - Step 3

Motor not included!

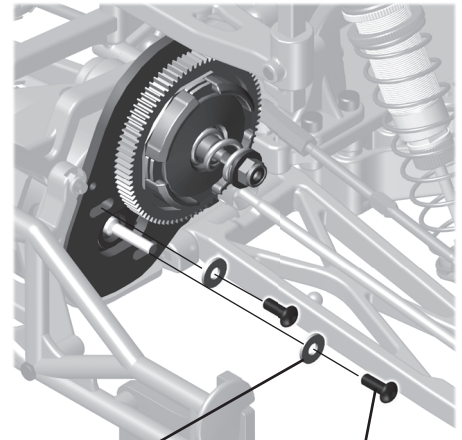
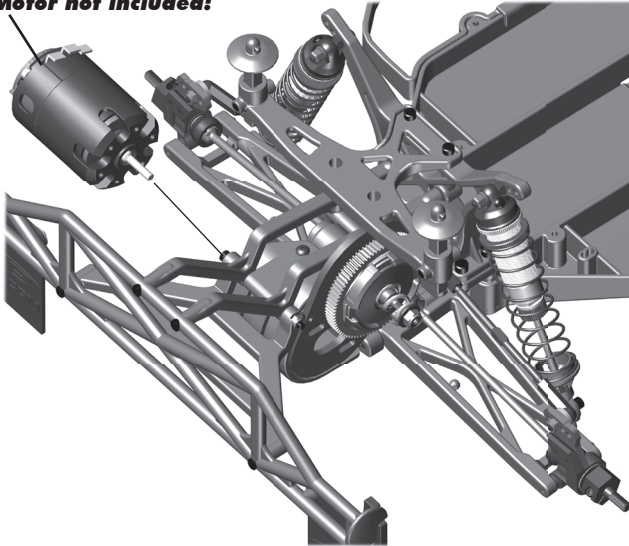

6936 
Washer #4
aluminum

31532 
M3x8mm
bhcs

:: Electronics Build - Bag H-HH - Step 4

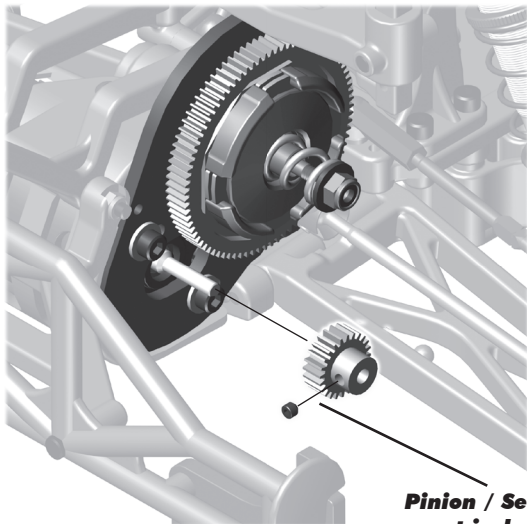

Pinion / Setscrew
not included!

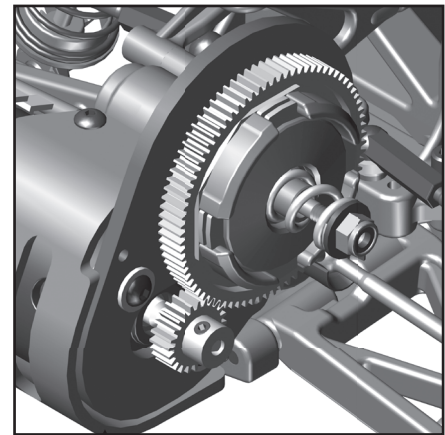

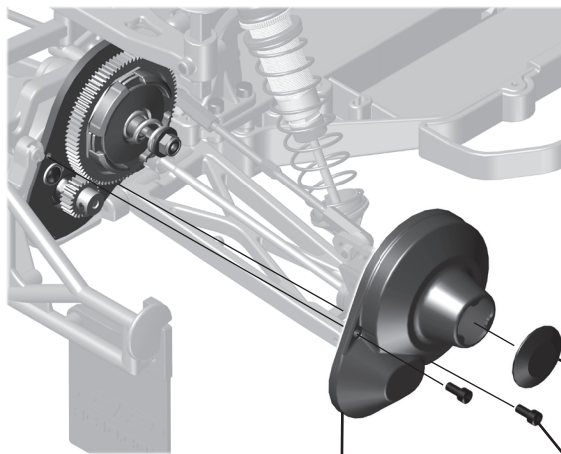

See page 20 for
 gear mesh setting
 instructions!

:: Electronics Build - Bag H-HH - Step 5

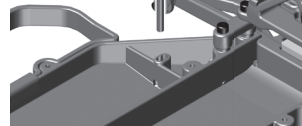

3862
5-40x1/8
set screw
6338
Antenna
tube & cap



7461
Gear cover
button
7461
Gear cover
(clear)
6285 
4-40x1/4
shcs

Receiver / Servo tape
not included!

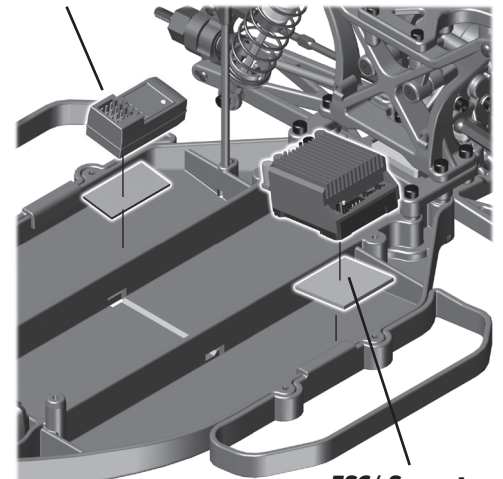

ESC / Servo tape
not included!

:: Electronics Build - Bag H-HH - Step 6

9815 
Foam spacer

9879 
Thumb knob

9879 
4-40x1/2 set screw

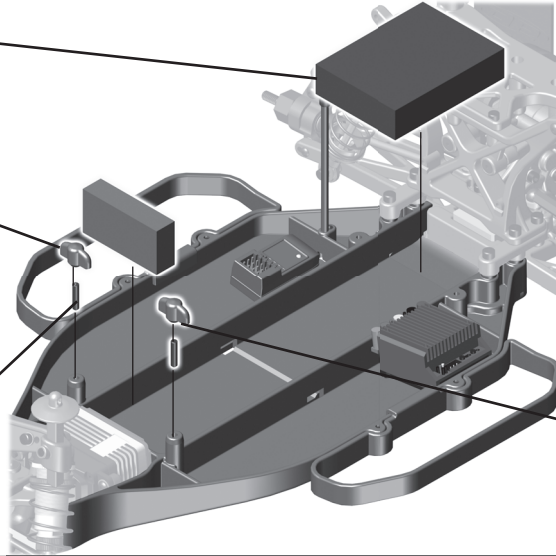

Trim the battery foam 18mm to move the battery pack towards the back.



:: Electronics Build - Bag H-HH - Step 7

9851
FT SC10
carbon fiber
battery strap

Battery
not included!

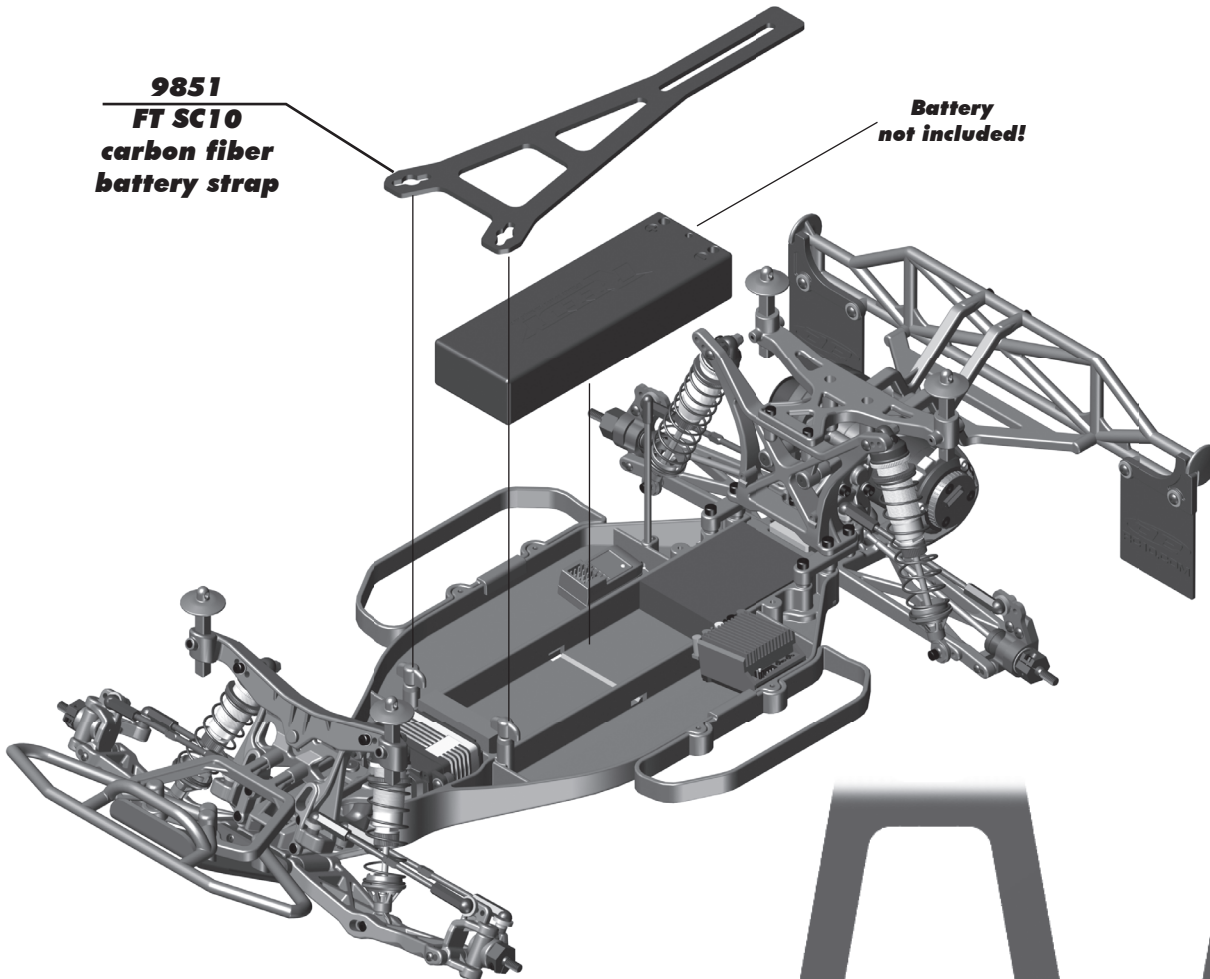

Move thumb knobs to the unlocked position and remove the battery strap to remove your battery pack. Lock the thumb knobs after you install you battery strap and battery pack!



:: Wheels / Tires and Body - Bag I - Step 1

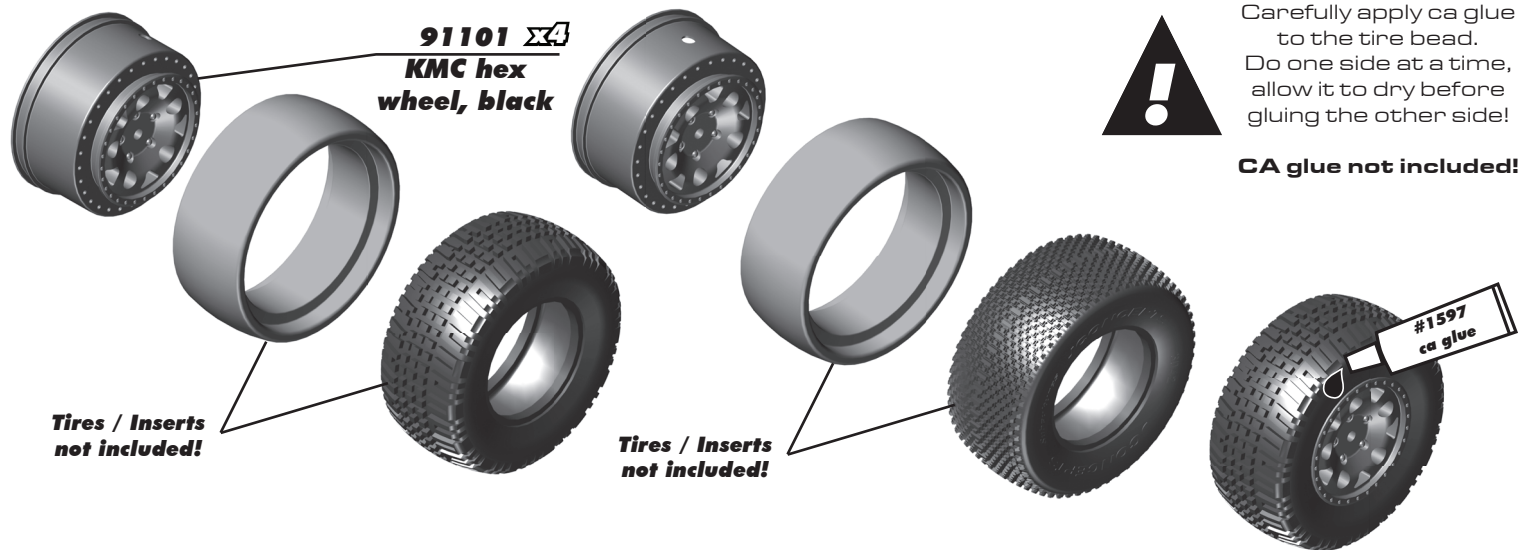

:: Wheels / Tires and Body - Bag I - Step 2

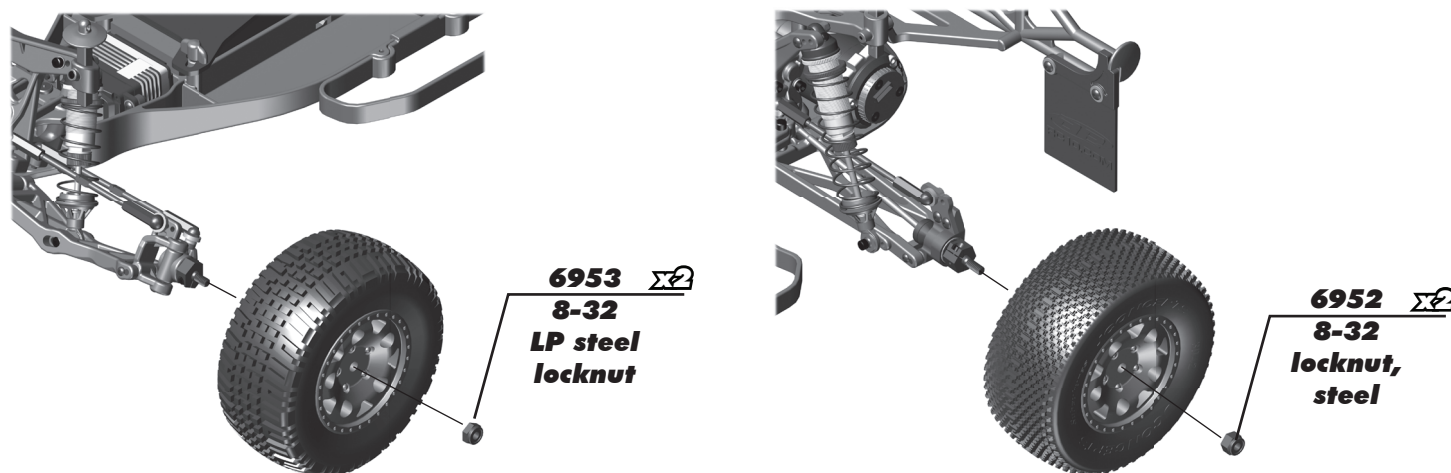

:: Wheels / Tires and Body - Bag I - Step 3

9876
SC10 Contender
Body
(clear)

6332 x4
Body
clips

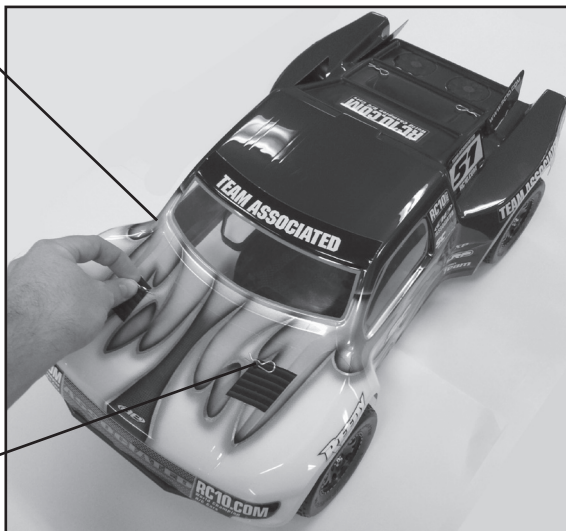

Painting Tips:

Your vehicle comes with a clear polycarbonate body. You will need to prep the body before you can paint it. Wash the inside thoroughly with warm water and liquid detergent. Dry the body using a clean, soft, lint-free cloth. Use the supplied window masks to cover the windows from the INSIDE of the body (RC cars get painted from the inside). Using high quality masking tape, apply tape to the inside of the body to create a design. Spray (either rattle can or airbrush) the paint to the inside of the body (preferably dark colors first, lighter colors last).

NOTE: use ONLY paint that is recommended for use with (polycarbonate) plastics. If you don't, you can destroy the plastic body!!!!

After painting, cut the body along the trim lines. Make sure to drill or use a body reamer to make the holes for the body mounts and antenna. The number plates are located below the fender wells and the rear fins are located below the bed section on the rear of the body.

:: Tuning Tips

Tips for Beginners:

Before making any changes to the standard setup, make sure you can get around the track without crashing. Changes to your vehicle will not be beneficial if you can't stay on the track. Your goal is consistent laps.

Once you can get around the track consistently, start tuning your vehicle. Make only ONE adjustment at a time, testing it before making another change. If the result of your adjustment is a faster lap, mark the change on the included setup sheet (make additional copies of the sheet before writing on it). If your adjustment results in a slower lap, revert back to the previous setup and try another change.

When you are satisfied with your vehicle, fill in the setup sheet thoroughly and file it away. Use this as a guide for future track days or conditions.

Periodically check all moving suspension parts. Suspension components must be kept clean and move freely without binding to prevent poor and/or inconsistent handling.

Motor Gearing:

Proper motor gearing will result in maximum performance and run time while reducing the chance of overheating and premature motor failure. The gear ratio chart lists recommended starting gear ratios for the most widely used motor types. Gear ratios will vary depending upon motor brand, wind, and electronic speed control. Consult your motor and electronic speed control manufacturers for more information. Team Associated is not responsible for motor damage due to improper gearing. *** These gearings are for use with advanced timing speed control settings!**

SC10.2 Gear Ratio Chart (Internal Gear Ratio 2.60:1)

Motor	Pinion	Spur	FDR
27T Reedy Stock	20	84	10.92:1
19T Reedy Super Stock	19	84	11.49:1
17.5 Reedy Sonic Brushless *	20	84	10.92:1
17.5 Reedy Sonic Brushless	27	75	7.22:1
13.5 Reedy Sonic Brushless *	18	84	12.13:1
13.5 Reedy Sonic Brushless	24	78	8.45:1
10.5 Reedy Sonic Brushless	21	84	10.40:1
9.5 Reedy Sonic Brushless	20	84	10.92:1
8.5 Reedy Sonic Brushless	20	84	10.92:1
7.5 Reedy Sonic Brushless	19	84	11.49:1
6.5 Reedy Sonic Brushless	18	84	12.13:1
3300kV Brushless	19	84	11.49:1
3900kV Brushless	19	84	11.49:1
4900kV Brushless	18	84	12.13:1
6100kV Brushless	17	84	12.85:1

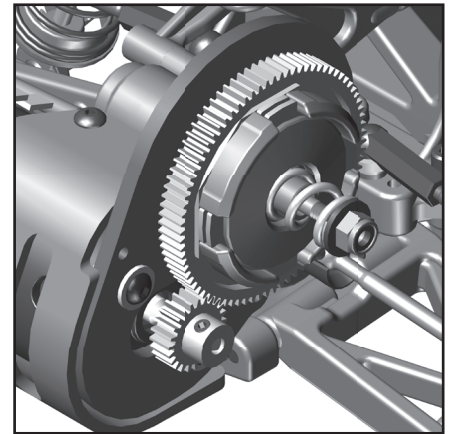

Set The Gear Mesh:

You should be able to rock the spur gear back and forth in the teeth of the pinion gear without making the pinion gear move. If the spur gear mesh is tight, then loosen the #31532 screws and move the motor away, then try again. A gear mesh that is too tight or too loose will reduce power and damage the gear teeth.

Motor Maintenance:

Brushed motors require frequent maintenance to keep performance levels at their maximum. Between runs and after letting the motor cool completely, inspect the brushes to ensure that they are moving freely in their holders.

Remove the springs and slide the brushes in and out of their holders checking for any resistance or rough spots.

If found, remove the brush and carefully wipe it clean. Removing buildup will allow the brush to slide freely and create maximum contact with the commutator resulting in maximum power output.

After every 3-5 runs, remove the brushes from their holders and inspect the tips for wear or burning if able. If there is noticeable wear (less than 75% of the brush remaining), it is best to cut the commutator and replace the brushes with a new pair. If the tips of the brushes become a burned blue color, the lubricant in the brush has been burned away and new brushes should be installed.

Occasionally, the motor should be cleaned with a soft brush to prevent dirt build up around the brush hood area and ball bearings. At this time, it is a good idea to add one drop of bushing / bearing oil to each bushing or ball bearing.

If using a brushless motor, please refer to the motor manufacturer's guidelines for proper maintenance.

Slipper Clutch:

The assembly instructions give you a base setting for your clutch. Turn the nut on the shaft so that the end of the top shaft is even with the outside of the nut. At the track, tighten or loosen the nut in 1/8 turn increments until you hear a faint slipping sound for 1-2 feet on takeoffs. Another popular way to set the clutch is to hold both rear tires firmly in place and apply short bursts of throttle. If the clutch is properly set, the front tires should lift slightly up off the surface.

:: Tuning Tips (cont.)

Front Camber Links:

Changing the length of the camber link is considered a bigger step than adjusting the ball end height on the tower. Shortening the camber link (or lowering the ball end) will give the front end less roll and quicken steering response. Lengthening the camber link (or raising the ball end) will give the front more roll and slower steering response. Longer camber links are typically used on high grip tracks and shorter links tend to work better on medium-grip loose tracks.



*Raise or lower the ball end by adding or subtracting washers here

Front Camber:

Camber describes the angle at which the tire and wheel rides when looked at from the front. Negative camber means that the tire leans inward at the top. A good starting camber setting is -1° . Use the included #1719 camber gauge to set your camber. Positive camber, where the top of the tire is leaning out, is not recommended.



*Testing camber with camber gauge

Caster:

Caster describes the angle of the kingpin as it leans toward the rear of the vehicle. Positive caster means the kingpin leans rearward at the top. The supplied 30° caster blocks (#7922) are recommended in most cases. For less corner entry steering and more exit steering, try the optional 25° blocks (#7919).

Rear Camber Link:

Changing the length of the camber link is considered a bigger step than adjusting the ball end height on the rear chassis brace. Shortening the camber link (or lowering the ball end) will give the rear end less roll and the car will tend to accelerate or "square up" better. Lengthening the camber link (or raising the ball end) will give the rear more roll and more cornering grip. Longer camber links are typically used on high grip tracks, while shorter links tend to work better on medium grip loose tracks. The kit setting is the best compromise of cornering grip and acceleration.

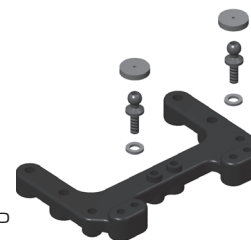

*Raise or lower the ball end by adding or subtracting washers here

Rear Camber:

Camber describes the angle at which the tire and wheel rides when looked at from the back. Negative camber means that the tire leans inward at the top. A good starting camber setting is -1° . Use the included #1719 camber gauge to set your camber. Adding a small amount of positive camber, where the top of the tire is leaning out, will tend to improve straight-line acceleration on loose tracks.

Ride Height:

Ride height is the distance from the ground to the bottom of the chassis. The standard front ride height setting is with the inner and outer hinge pins of the front arms level on the same imaginary horizontal line, or 30mm as measured from the bottom of the chassis directly behind the front bumper.

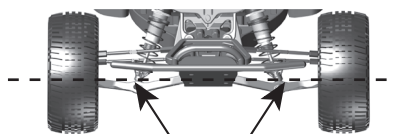

*Front arms inner and outer hinge pins should be in a imaginary horizontal line when ride height is set

The rear ride height setting you should use most often is with the outdrive, driveshaft, and axles all on the same imaginary horizontal line (referred to as "bones level") or 28mm.

Check the ride height by lifting up the entire car about 8-12 inches off the bench and drop it. After the suspension "settles" into place, measure ride height (Ride Height Gauge #1449). Raise or lower the shock collars as necessary.

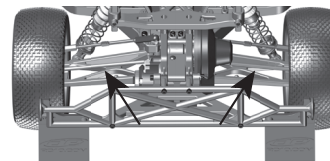

*CVA bones should be in a straight line when ride height is set at "CVA bones level"

Wheelbase Adjustment:

You have three options for rear hub spacing, Forward, Middle, & Back. The kit setting provides the most rear traction, and will be used most often. For improved handling in bumps or rhythm sections, try moving the hubs to the Middle or Back position. This can also make the car handle better in 180° turns.

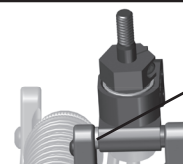

*Spacers to the rear will place hubs forward, shortening the wheelbase

Anti-Roll Bars:

The optional #9635 rear anti-roll bar kit (also called the "swaybar") allows you to add roll resistance to the rear end with minimal effect on handling over bumps and jumps. It is an especially helpful tuning item on high-grip tracks (try the gold bar). The silver and black anti-roll bars are typically used on medium-grip loose tracks.

:: Shocks

1777 FT Blue Aluminum Shock Pivot Ball with Eyelet	4 ea.
4187 .030 Nylon Washer	12
5407 Red O-Rings	8
6299 E-Clip	12
31327 VCS3 Shock Bottom Cap and O-Ring	2 ea.
31510 M2 x 4mm BHCS	6
91300 12X27.5mm FT Shock Bodies (front)	2
91302 12X36mm FT Shock Bodies (rear)	2
91303 12MM Shock Cap	2
91304 12MM Threaded Collar and O-Ring	2
91306 27.5X3mm TiN Shock Shaft (front)	1
91307 35X3mm TiN Shock Shaft (rear)	1
91308 12MM Shock Pistons, (1.5, 1.6, 1.7)	4 ea.
91309 12MM Shock Rebuild Kit	1
91310 12MM Shock Spring Cups (+0mm, +5mm, +9mm)	4 ea.
91315 12MM Shock (T4/SC10 Front)	2
91317 12MM Shock (T4/SC10 Rear)	2

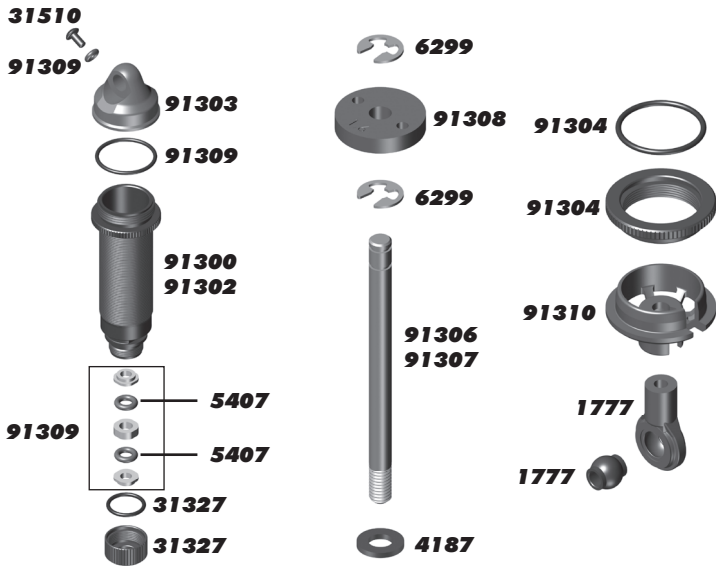

:: Shock Springs

91325 12MM Front SPRING BRN 2.85	Pr.
91326 12MM Front SPRING BLK 3.00	Pr.
91327 12MM Front SPRING GRN 3.15	Pr.
91328 12MM Front SPRING WHT 3.30	Pr.
91329 12MM Front SPRING GRY 3.45 - Kit	Pr.
91330 12MM Front SPRING BLU 3.60	Pr.
91331 12MM Front SPRING YLW 3.75	Pr.
91332 12MM Front SPRING RED 3.90	Pr.
91333 12MM Front SPRING ORN 4.05	Pr.
91334 12MM Front SPRING PRL 4.20	Pr.
91335 12MM Rear SPRING BLK 1.90	Pr.
91336 12MM Rear SPRING GRN 2.00	Pr.
91337 12MM Rear SPRING WHT 2.10 - Kit	Pr.
91338 12MM Rear SPRING GRY 2.20	Pr.
91339 12MM Rear SPRING BLU 2.30	Pr.
91340 12MM Rear SPRING YLW 2.40	Pr.
91341 12mm Big Bore Front Soft Spring Kit	1
91342 12mm Big Bore Front Medium Spring Kit	1
91343 12mm Big Bore Front Hard Spring Kit	1
91344 12mm Big Bore Rear Soft Spring Kit	1
91345 12mm Big Bore Rear Medium Spring Kit	1



:: Ball Differential

6573 Diff Thrust Washer & Bolt	2
6574 Precision Diff Thrust Balls, 5/64"	6
6575 Locking T-Nut, Diff Thrust Bolt, & Cover	1
6581 3/32" Carbide Diff Balls	12
6582 Diff Thrust Spring	1
6589 Ball Bearing, 5/32 x 5/16" unflanged	2
7664 Diff Gear 52T	1
7666 Diff Drive Rings, 2.60:1	2
7677 Diff Rebuild Kit, Offroad	1
9852 SC10 Ball Diff Outdrives	1
9853 SC10 Complete Ball Differential	1

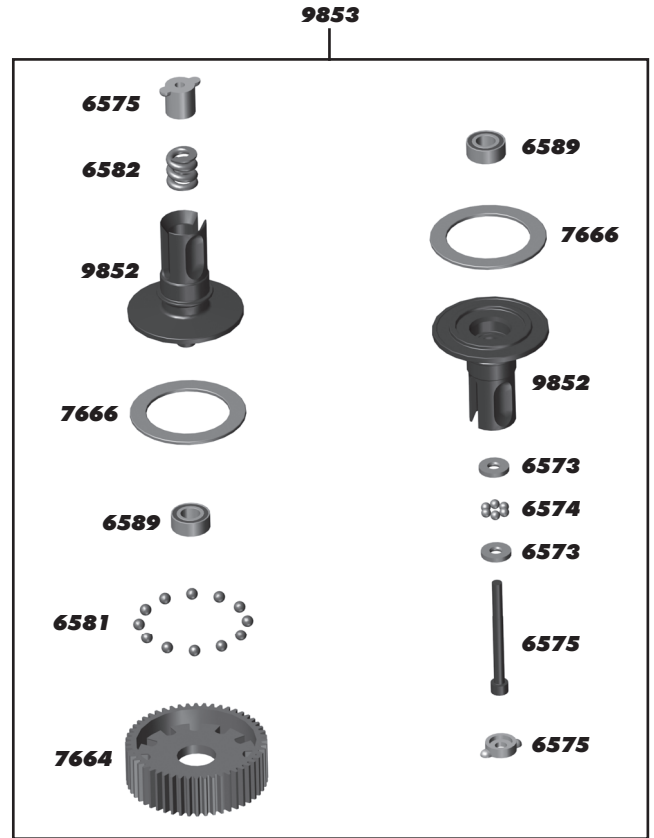

:: Shock Oil

5420 10 Weight Silicone Shock Oil	2oz.
5421 20 Weight Silicone Shock Oil	2oz.
5422 30 Weight Silicone Shock Oil	2oz.
5423 40 Weight Silicone Shock Oil	2oz.
5424 22.5 Weight Silicone Shock Oil	2oz.
5425 80 Weight Silicone Shock Oil	2oz.
5426 27.5 Weight Silicone Shock Oil	2oz.
5427 15 Weight Silicone Shock Oil	2oz.
5428 25 Weight Silicone Shock Oil	2oz.
5429 35 Weight Silicone Shock Oil	2oz.
5430 45 Weight Silicone Shock Oil	2oz.
5431 55 Weight Silicone Shock Oil	2oz.
5432 32.5 Weight Silicone Shock Oil	2oz.
5433 37.5 Weight Silicone Shock Oil	2oz.
5434 42.5 Weight Silicone Shock Oil	2oz.
5435 50 Weight Silicone Shock Oil	2oz.
5436 60 Weight Silicone Shock Oil	2oz.
5437 70 Weight Silicone Shock Oil	2oz.
5438 47.5 Weight Silicone Shock Oil	2oz.



:: Slipper Clutch

6285	4-40 x 1/4" SHCS	12
6629	5-40 Diff Locking Nut	6
7461	Molded Gear Cover, Clear	1
7485	FT V2 Slipper Hubs	2
7486	FT V2 Slipper Spring and Washer	1
9603	Slipper Pad	2
9649	72T 48P Spur Gear	1
9650	75T 48P Spur Gear	1
9651	81T 48P Spur Gear (Kit)	1
9652	78T 48P Spur Gear	1
9653	84T 48P Spur Gear	1
9739	Slipper Spring	1
91175	FT VTS Slipper Conversion	1
91176	VTS Slipper Housing	1
91177	VTS Slipper Pads	2
91178	VTS Slipper Plate	1
91179	FT VTS Slipper Hub, outer	1

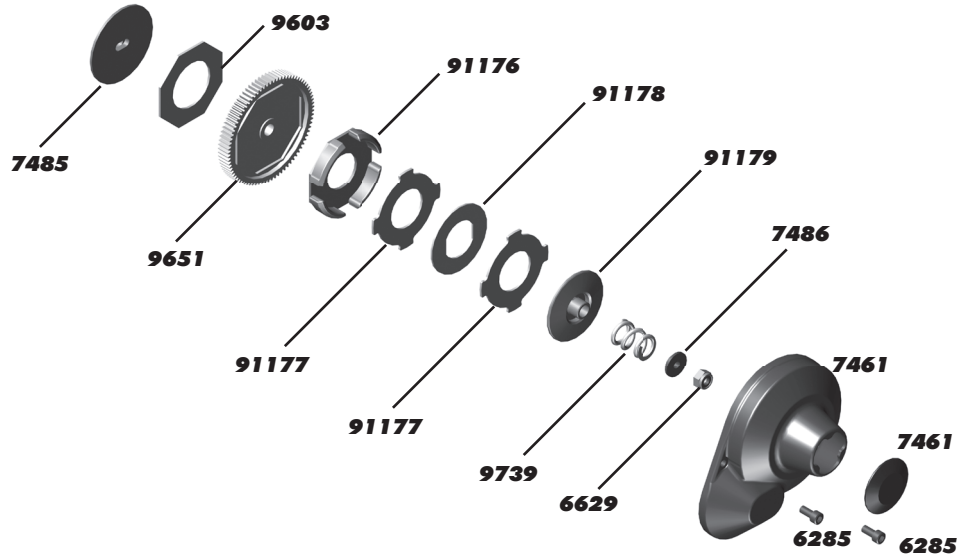

:: Optional Gear Differential

9827	Complete Gear Diff	1
9828	Diff Gear and Cover Set	1
9829	Gear Diff Rebuild Kit	1
9830	Gear Diff Outdrives	Pr.
9831	Gear Diff O-Ring Set	1
9888	0.5mm Gear Diff Shim	2



:: Differential Fluids

5450	Silicone Diff Fluid 1,000CST	1
5451	Silicone Diff Fluid 2,000CST	1
5452	Silicone Diff Fluid 3,000CST	1
5453	Silicone Diff Fluid 5,000CST	1
5454	Silicone Diff Fluid 7,000CST	1
5455	Silicone Diff Fluid 10,000CST	1
5456	Silicone Diff Fluid 20,000CST	1
5457	Silicone Diff Fluid 30,000CST	1
5458	Silicone Diff Fluid 60,000CST	1
5459	Silicone Diff Fluid 100,000CST	1

:: Turnbuckles and Servo Mounts

1408	FT Blue Titanium Turnbuckles, 2.65"	2
1417	FT Blue Titanium Turnbuckles, 2.80"	2
1779	FT Servo Mount, blue	2
3981	Ballstud .20" Black, short	6
6272	Foam Ballend Dust Covers	28
6292	4-40 x 3/8" FHCS	6
6917	4-40 x 3/8" BHCS	6
7230	Ballups, Large	12
7336	Steering Servo Mount Kit	1
7337	.250 x .125 x .015" Washer	4
9170	Steering Servo Link	1
9180	Servo Horns, Molded	1
89007	Steering Servo Ring, blue	1

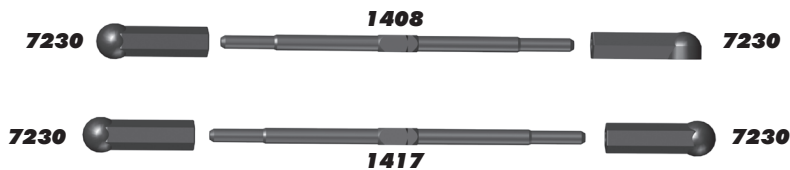

:: Front Bulkhead / Steering

3971	.125 x .250 x .109" Bearings	4
3981	Ballstud .20 Black, short	6
6272	Foam Ball end Dust Covers	28
6276	Ballstud .20" Silver (short)	6
6917	4-40 X 3/8" BHCS	6
6922	4-40 x 1/2" FHCS	6
9566	B4 / T4 Top Plate	1
9640	B4 / T4 Steering Bolt, left & right	1
9647	Steering Block Bushing	4
9659	Steering Set B4/T4	1
9679	B4/T4 Aluminum Bellcrank Set	1
89229	Blue Countersunk Washers	10

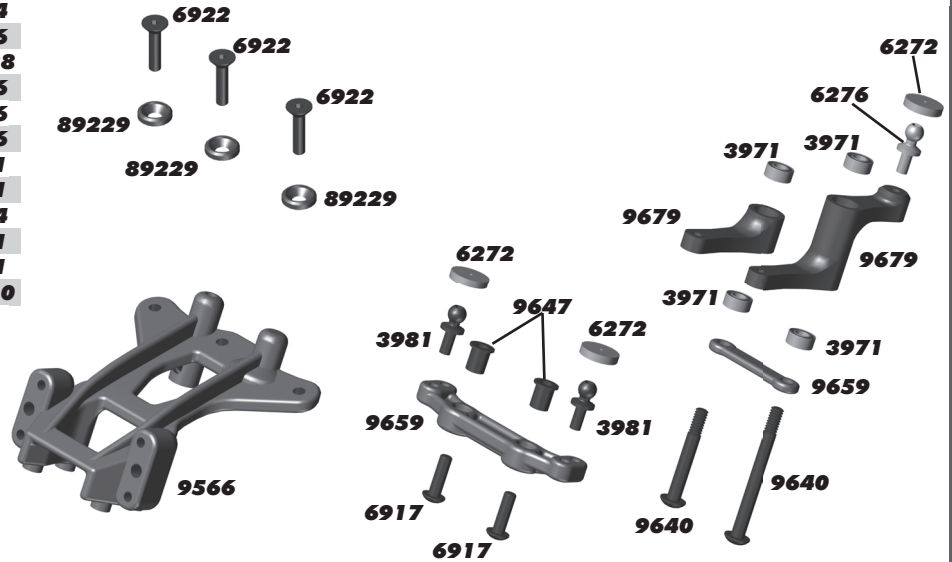

:: Front Bumper

6292	4-40 x 3/8" FHCS	6
6915	4-40 x 5/8" FHCS	6
6925	4-40 x 1/2" SHCS	6
9816	SC10 Front Skid, Bumper Set	1

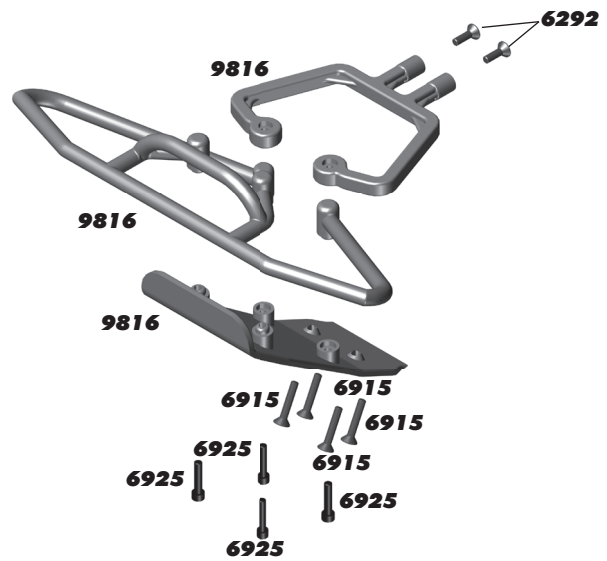

:: Front Shock Tower

1780	FT Shock Bushing, standard (blue)	4
6272	Foam Ballend Dust Covers	28
6277	Ballstud .30 Silver (short)	4
6332	Body Clips	6
6472	4-40/5-40 Plastic Nut	4
6917	4-40 X 3/8" BHCS	6
6924	4-40 x 3/8" SHCS	6
6928	4-40 x 1" SHCS	6
9630	.030 Ballstud Washer	10
9667	2-56x5/8 SHCS	6
9899	SC10.2 Body Mount Set	1
31286	FT Ballstud Washer, aluminum (1mm, 2mm)	4ea
91202	SC10B Front Shock Tower	1

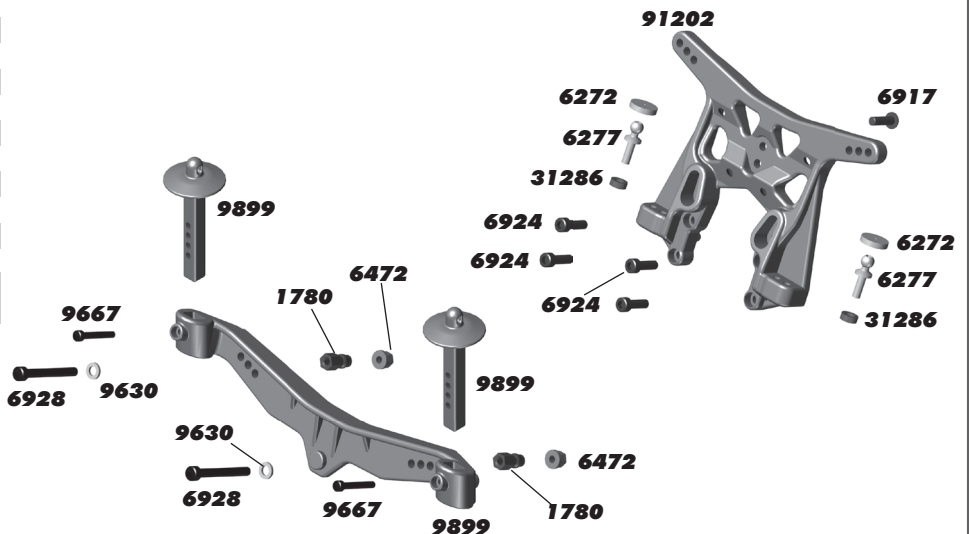

:: Battery Strap

9238	Foam Battery Spacers, Set	1
9815	Foam Battery Spacer	1
9851	FT SC10 Carbon Fiber Battery Strap	1
9879	SC10 RTR Battery Strap	1

(includes setscrews and thumb knobs)

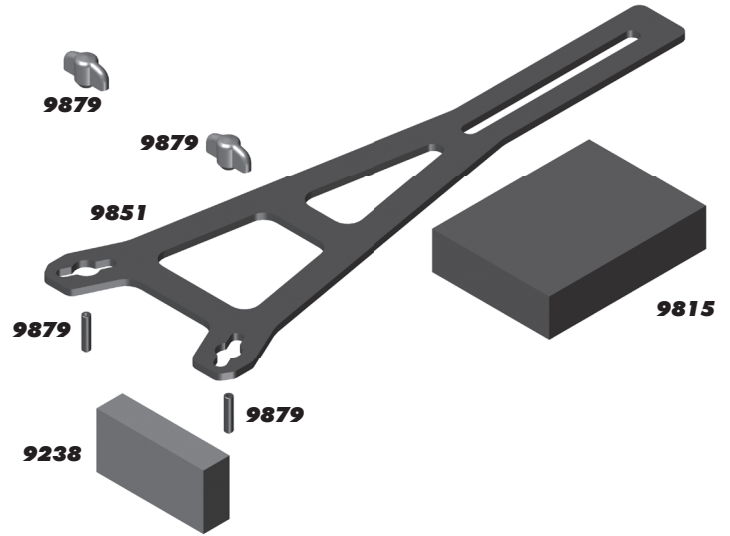

:: Rear Shock Tower

1781	FT Shock Bushings, short, (blue)	4
6332	Body Clips	6
6472	4-40/5-40 Plastic Nut	4
6915	4-40 x 5/8" FHCS	6
6924	4-40 x 3/8" SHCS	6
7413	4-40 x 3/4" BHCS	6
9643	5-40 x 7/16" SHCS	6
9644	5-40 x 9/16" SHCS	6
9667	2-56x5/8 SHCS	6
9824	T4 Rear Shock Tower	1
9899	SC10.2 Body Mount Set	1

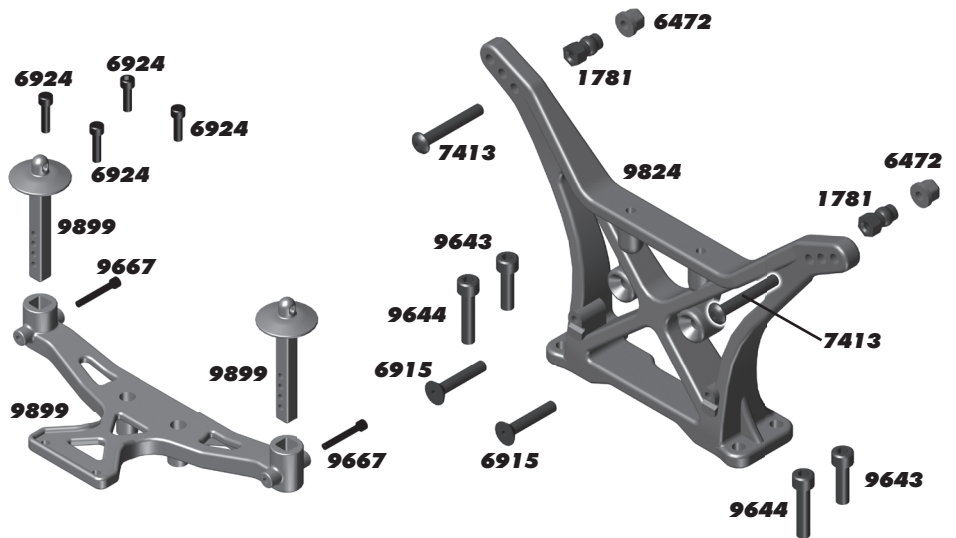

:: Rear Bumper

4449	4-40 x 3/16" Aluminum Locknut	5
6913	4-40 x 1 1/4" SHCS	6
6917	4-40 x 3/8" BHCS	6
6925	4-40 x 1/2" SHCS	6
9817	SC10 RR Bumper and Brace, Includes Bumper, Braces (left, right, upper, and lower),	1
9833	4-40 x 1 3/4" SHCS	6
89218	3x8mm washer	10
89430	Mud Flaps	Pr.

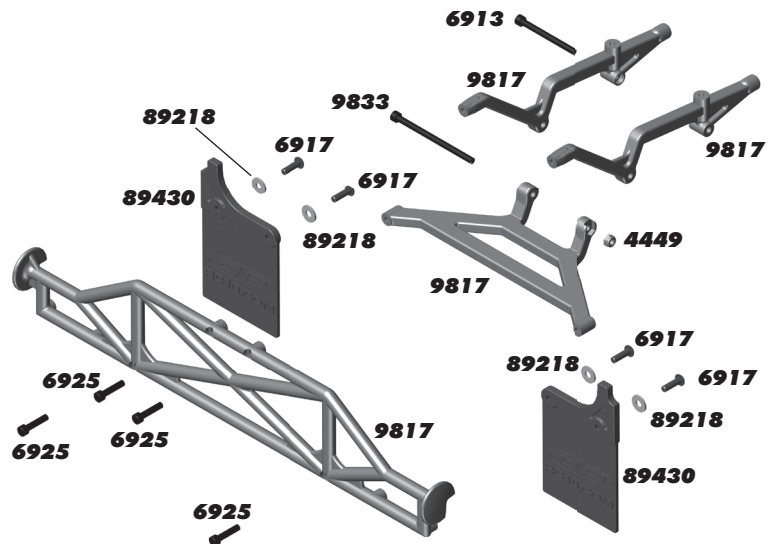

:: Transmission

1770	FT Milled Motor Plate, blue	1
3977	Ball Bearing, 3/16" x 3/8"	2
6913	4-40 x 1 1/4" SHCS	6
6919	4-40 X 5/16" BHCS	6
6922	4-40 X 1/2" FHCS	6
6924	4-40 X 3/8" SHCS	6
6925	4-40 x 1/2" SHCS	6
6928	4-40 x 1" SHCS	6
6936	#4 Washer, aluminum	10
9360	Idler Gear, molded	1
9361	Idler Gear Shaft	1
9601	B4/T4 Top Shaft	1
9602	B4/T4 Top Shaft Spacer	1
9630	Ballstud Washer	10
9819	Rear Motor Guard	1
9826	Transmission Case for Gear Diff (left & right)	1
9832	Ball Bearing, 10 x 16mm	2
31532	M3 x 8mm BHCS	6

:: Pinion Gears

8253	16T 48P Pinion Gear	1
8254	17T 48P Pinion Gear	1
8255	18T 48P Pinion Gear	1
8256	19T 48P Pinion Gear	1
8257	20T 48P Pinion Gear	1
8258	21T 48P Pinion Gear	1
8259	22T 48P Pinion Gear	1
8260	23T 48P Pinion Gear	1
8261	24T 48P Pinion Gear	1
8263	26T 48P Pinion Gear	1
8264	27T 48P Pinion Gear	1
8265	28T 48P Pinion Gear	1
8266	29T 48P Pinion Gear	1
8267	30T 48P Pinion Gear	1
8268	31T 48P Pinion Gear	1
8269	32T 48P Pinion Gear	1
8270	33T 48P Pinion Gear	1
8271	34T 48P Pinion Gear	1
8272	35T 48P Pinion Gear	1

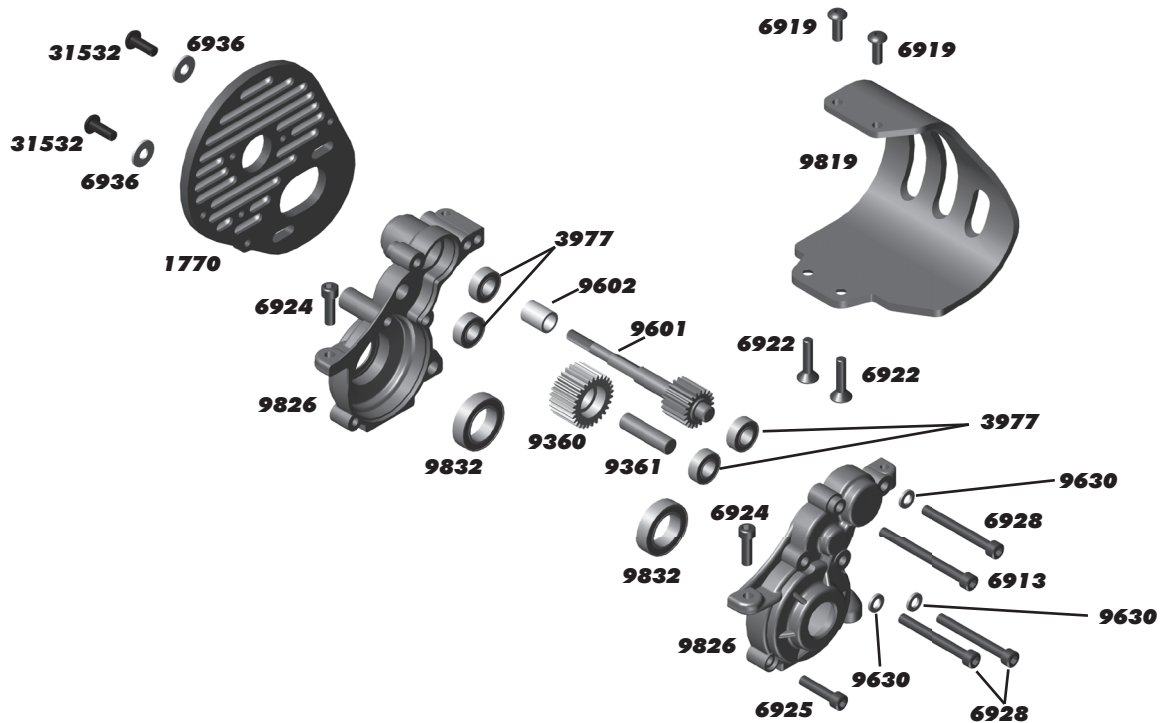

:: Wheels

9809	SC10 Tire, With Foam Insert - Kit	2
89413	Molded Tire Insert	2
91101	KMC Hex Wheels, Black (Kit)	2
91102	KMC Hex Wheels, Silver	2
91103	KMC Hex Wheels, Chrome	2
91104	KMC Hex Wheels/Tire Mounted Black	2
91105	KMC Hex Wheels/Tire Mounted Silver	2
91106	KMC Hex Wheels/Tire Mounted Chrome	2

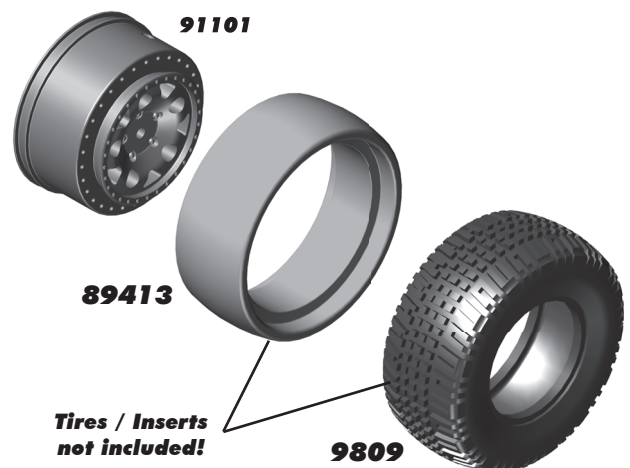

:: Chassis

3862	5-40 x 1/8" Set Screw	6
4334	2-56 x 5/16" BHCS	8
6272	Foam Ballend Dust Cover	28
6277	Ballstud .30" Silver (long)	4
6338	Antenna Tube & Cap (black)	1
6915	4-40 X 5/8" FHCS	6
6917	4-40 x 3/8" BHCS	6
7487	Arm Mounts 2.5, 3, 3.5, 4 deg Set	1
7488	Ballast Weight	1
9269	5-40 x 1/2" FHCS	6
9563	B4 / T4 / GT2 Front Bulkhead	1
9564	RR / FR Hinge Brace	1
9621	Inner Hinge Pin Set	4
9643	5-40 x 7/16" SHCS	6
9645	2-56 x 1/8" BHCS	8
9665	FT Hinge Pin Brace, blue	1
9818	B4/T4/SC10 Arm Mount / Chassis Plate	1
9822	SC10 Nerf Bars (1 left & 1 right)	1
9823	SC10 Chassis	1
31286	Aluminum Ballstud Washer (1mm & 2mm)	4ea

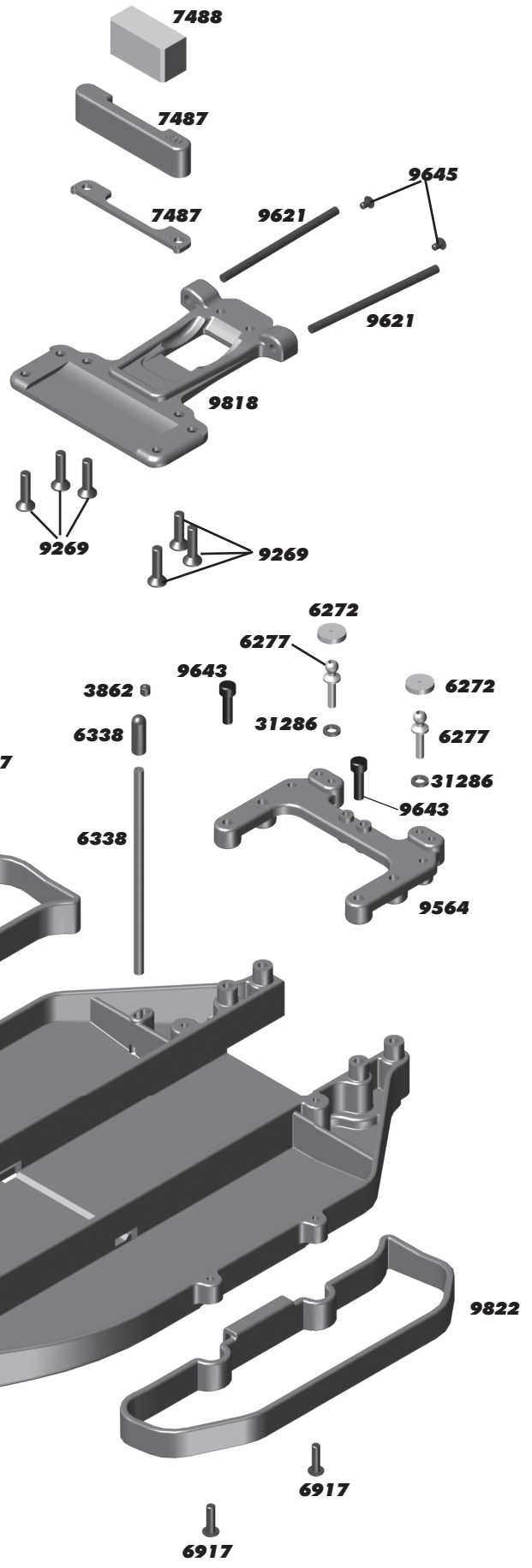

:: Factory Team and Option Parts

1283	FT Ti Turnbuckle Set, T4	1
1408	FT Ti Turnbuckle, 2.65" (blue)	Pr.
1409	FT Ti Turnbuckle, 1" (sway bar) (blue)	Pr.
1654	FT Solid Axle Pins	4
1734	FT Blue Body Clip, 4 long, 6 short	10
1735	FT Blue Body Clip, long	4
1736	FT Blue Body Clip, short	6
1770	FT Milled Aluminum Motor Plate, (blue)	1
1777	Blue Aluminum Shock Ball Ends with Eyelets	4
1778	FT Milled Aluminum Motor Plate, (black)	1
1779	FT Servo Mounts, blue aluminum	Pr.
1780	FT Blue Alum. Threaded Shock Bushings (standard)	4
1781	FT Blue Alum. Threaded Shock Bushings (short)	4
1787	FT Battery Strap Thumb Screws	Pr.
3971	Steering Rack Bearings	4
6906	Ball Bearing, PTFE Sealed 3/16 x 3/8"	2
6937	FT 4-40 Aluminum Locknuts (blue)	6
6943	FT 8-32 Aluminum Locknuts (blue)	6
7381	CVD Rebuild Kit	1
7441	T4 Chassis, Carbon	1
7445	FT Rear Shock Tower, Carbon	1
7449	FT Rear Suspension Arms, Carbon	Pr.
7453	CVD Axle Bone, T4	2
7455	CVD Set, T4	1
7485	FT V2 Slipper Hubs	Pr.
7486	FT V2 Slipper Spring and Washer	1
7487	Arm Mount Set (2.5, 3, 3.5, 4 deg)	1
7922	Caster Block 30 deg, (left & right)	Pr.
7990	Aluminum Front Bulkhead	1
9565	Chassis Brace, Hinge Pin Brace, Carbon	1
9567	Top Plate, Carbon	1
9592	Caster Block 20 deg, (left & right)	Pr.
9593	FT Caster Block, 30 deg, (left & right)	Pr.
9598	CVD Axles, B4 / T4	Pr.
9600B	FT Aluminum Motor Plate (blue)	1
9635	B4 / T4 Sway Bar Kit. Includes color coded bars, soft (black), med (silver), hard (gold)	1
9665	FT B4 / T4 Aluminum Hinge Pin Brace	1
9678	FT SC10/T4 CVA Set	1
9679	B4/T4 Aluminum Bellcrank Set	1
9739	Slipper Spring	1
9755	CVA Axle, Rear (B44, B4, T4, SC10)	Pr.
9789	FT Titanium Front Axles, SC10 / B4	Pr.
9795	Ti Nitride Ballstuds 4-40 x 0.20" Long	Pr.
9796	Ti Nitride Ballstuds 4-40 x 0.30" Long	Pr.
9797	Ti Nitride Ballstuds 4-40 x 0.40" Long	Pr.
9798	Ti Nitride Ballstuds 4-40 x 0.20" Short	Pr.
9799	Ti Nitride Ballstuds 4-40 x 0.30" Short	Pr.
9864	FT Aluminum Hub, 0 deg	Pr.
9865	FT Aluminum Hub, 0.5 deg	Pr.
9866	FT Aluminum Hub, 1 deg	Pr.
9867	FT Aluminum Hub, 1.5 deg	Pr.
9872	FT Aluminum Hub Tower Set	1
9917	Aluminum Hub A, Carbon	Pr.
9918	Aluminum Hub Tower B, Graphite	Pr.
31237	CVA Pin Retaining Clip	Pr.
31286	FT Ballstud Washer, aluminum (1mm, 2mm)	4ea.
91175	FT VTS Slipper Conversion	1
91176	VTS Slipper Housing	1
91177	VTS Slipper Pads	2
91178	VTS Slipper Plate	1
91179	FT VTS Slipper Hub, outer	1

:: Body and Decals

9836	SC10 Body, clear	1
9837	SC10 09' Championship Body, clear	1
9838	SC10 KMC™ Body, painted	1
9842	SC10 AE Body, painted	1
9843	SC10 Decal Sheet, KMC™	1
9844	SC10 Decal Sheet, Lucas Oil	1
9846	SC10 Decal Sheet, Pro Comp	1
9847	SC10 Decal Sheet, Team AE	1
9848	SC10 ReadyLift Body, painted	1
9849	SC10 Decal Sheet, ReadyLift	1
9850	SC10 Number Plate Decals	1
9856	SC10 09' Lucas Oil Body, painted	1
9857	SC10 '09 Decals, Lucas Oil	1
9858	SC10 09' Pro Comp Body, painted	1
9859	SC10 '09 Decals, Pro Comp	1
9860	SC10 09' Speed Technologies Body, painted	1
9861	SC10 '09 Decals, Speed Technologies	1
9862	SC10 09' Rockstar-Makita Body, painted	1
9863	SC10 '09 Decals, Rockstar-Makita	1
9874	SC10 09' Monster Energy Body, painted	1
9875	SC10 Monster Energy Decals	1
9876	SC10 Contender Body, clear	1
9886	SC10 09' Slick Mist Body, painted	1
9887	SC10 Slick Mist Body Decal Sheet	1
9896	SC10 09' Hart and Huntington Body, painted	1
9897	'09 Hart and Huntington Decal Sheet	1
9920	SC10.2 Decal Sheet	1

:: XP Electronics

29107	S1903 Metal Gear Set	1
29125	S1903MG Servo	1
29126	S2008MG Servo	1
29133	XP DS1903 Servo	1
29134	XP DS1903MG Servo	1
29135	XP DS2008MG Servo	1
29138	XP SC500 Brushless ESC	1
29141	XP SC450-BL Brushless ESC	1
29142	XP ESC Fan Option	1
29143	XP SC700-BL Brushless ESC	1
29144	XP SC1200 Brushless ESC	1
29145	XP SC1300 Brushless ESC	1
29166	XP DS1313 Digital Servo	1
29167	XP DS1015 Digital Servo	1
29209	Gear Set, DS1313	1
29210	Gear Set, DS1015	1
29211	Servo Case, DS1313 / DS1015	1
29212	Accessory Pack, DS1313 / DS1015	1
29214	TRS 403-SSi Receiver	1
29215	XP2G 2.4GHz Radio System	1
29216	XP3G 2.4GHz Radio System	1
29217	XP TRS402-SSi Receiver	1
29218	XP2-SSi 2.4GHz Radio System	1
29221	XP3SS 2.4GHz Radio System	1

:: Reedy Accessories

604	526-S AC/DC 2S-6S LiPo/LiFe Charger	1
605	Motor Cooling Fans (2)	1
606	Charge Harness 2S Saddle Pack 4mm	1
607	Charge Harness 2S Standard Pack 4mm	1
654	4.0mm plugs (2M, 2F)	1
655	4.0mm plugs (2M, 10F)	1
656	4.0mm plugs (10F)	1
658	4.0mm plugs (10M)	1
659	4.0mm plugs (30M)	1
660	3.5mm plugs (3M, 3F)	1
661	3.5mm plugs (10F)	1
663	3.5mm plugs (10M)	1
664	3.5mm plugs (30M)	1
716	Reedy 09 Decal Set	1
959	Sonic 540/550 Sensor w/Bearing	1
960	Sonic 540/550 Insulator Set (2 pcs.)	1
961	Sonic 540/550 Timing Cap w/Screws	1
962	Sonic 540 Case Screws (3 pcs.)	1
972	Sonic 540 Steel Bearing Set	1
973	Sonic 540 Ceramic Bearing Set	1
974	540-SL/550-SL Steel Bearing Set	1
975	540-SL/550-SL Ceramic Bearing Set	1
978	Flat Sensor Wire 70mm	1
979	Flat Sensor Wire 110mm	1
980	Flat Sensor Wire 150mm	1
981	Flat Sensor Wire 200mm	1
982	Flat Sensor Wire 270mm	1
992	Sonic 540 Rotor Spacers	1

:: Reedy Batteries

302	AA Alkaline 1.5V (4)	1
303	AA 2700mAh NiMH 1.2V Rechargeable	1
309	7000mAh 65C 7.4v LiPo	1
601	6500mAh 65C Competition 7.4V LiPo	1
602	4100mAh 65C Competition 7.4V Shorty LiPo	1
628	5500mAh 7.4V 60C LiPo	1
632	TX Lightweight Battery 1350mAh 11.1V	1
633	TX Battery - 3PK, M11 3000mAh 11.1V	1
634	TX Battery - Helios, Z1 2400mAh 11.1V	1
637	TX Battery - M11X 2500mAh 7.4V	1
736	WolfPack 5000mAh 25C 7.4V LiPo	1
738	WolfPack 3800mAh Shorty 7.4V 25C	1

:: Reedy Motors and ESC's

908	Replacement Rotor 540-SL	1
920	540-SL Brushless Motor 3300kV	1
921	540-SL Brushless Motor 3900kV	1
922	540-SL Brushless Motor 4900kV	1
923	540-SL Brushless Motor 6100kV	1
940	Sonic 540 21.5 Competition Brushless Motor	1
941	Sonic 540 17.5 Competition Brushless Motor	1
941S	Sonic 540 17.5 Replacement Stator	1
942	Sonic 540 13.5 Competition Brushless Motor	1
943	Sonic 540 10.5 Competition Brushless Motor	1
944	Sonic 540 9.5 Competition Brushless Motor	1
945	Sonic 540 8.5 Competition Brushless Motor	1
946	Sonic 540 7.5 Competition Brushless Motor	1
947	Sonic 540 6.5 Competition Brushless Motor	1
948	Sonic 540 5.5 Competition Brushless Motor	1
949	Sonic 540 5.0 Competition Brushless Motor	1
950	Sonic 540 4.5 Competition Brushless Motor	1
951	Sonic 540 4.0 Competition Brushless Motor	1
952	Sonic 540 3.5 Competition Brushless Motor	1
954	Sonic 540 Stock Rotor 12.3 x 24.2 (7.25)	1
955	Sonic 540 Stock Rotor 12.3 x 25.0 (7.25)	1
956	Sonic 540 Stock Rotor 12.5 x 25.0 (7.25)	1
957	Sonic 540 Modified Rotor 12.2 x 25.0 (5.0)	1
958	Sonic 540 Modified Rotor 12.5 x 25.0 (5.0)	1
987	Sonic 540 Modified Rotor 13.0 x 25.3 (5.0)	1

:: LRP Speed Controls

LRP80230	Spin Super Brushless	1
LRP80250	Spin Pro Brushless	1
LRP80970	Flow Works Team	1

:: LRP Brushless Motors / Combos

LRP50430	Vector K4 6.5 Turn	1
LRP50440	Vector K4 8.5 Turn	1
LRP50450	Vector K4 10.5 Turn	1
LRP50460	Vector K4 13.5 Turn	1
LRP50480	Vector K4 17.5 Turn	1
LRP50643	Vector X-20 10.5 Turn	1
LRP50644	Vector X-20 9.5 Turn	1
LRP50654	Vector X-20 8.5 Turn	1
LRP50664	Vector X-20 7.5 Turn	1
LRP50674	Vector X-20 6.5 Turn	1
LRP50684	Vector X-20 5.5 Turn	1
LRP50689	Vector X-20 5.0 Turn	1
LRP50694	Vector X-20 4.5 Turn	1
LRP50704	Vector X-20 4.0 Turn	1
LRP80741	Spin Super / K4 17.5 Turn	1
LRP80742	Spin Super / K4 13.5 Turn	1
LRP80743	Spin Super / K4 10.5 Turn	1
LRP50834	Vector X-20 Stock Spec 10.5T	1
LRP50844	Vector X-20 Stock Spec 13.5T	1
LRP50854	Vector X-20 Stock Spec 17.5T	1
LRP50864	Vector X-20 Stock Spec 21.5T	1

:: LRP Chargers, Power Supply, Balancer

LRP41281	Quadra Pro 2 Charger	1
LRP41555	Pulsar Touch Competition Charger	1
LRP42103	LiPo Balance Board XH	1
LRP42104	LiPo Balance Board FP/TP	1
LRP42105	LiPo Balance Board PQ	1
LRP42305	Pulsar Touch Temperature Sensor	1
LRP42306	Pulsar Touch Sensor Wire Splitter	1
LRP43200	LRP Competition 20A Power Supply	1
LRP45050	LRP 2in1 LiPo Guard + BEC	1
LRP45200	LiPo Parallel Balancer	1
LRP65800	High Power Solder Station	1
LRP65802	Soldering Tip 5mm	1
LRP65803	Soldering Tip 1.2mm	1
LRP65804	Soldering Handle	1
LRP81801	LRP Speedo Updater Spec 2	1

:: LRP Misc.

LRP50621	X-12 Optional Ceramic Ball Bearings	1
LRP50622	X-12 Small Parts Set	1
LRP50623	X-12 PreciSensor Unit	1
LRP50626	X-12 Alum Rear Cover	1
LRP50632	X-12 12.0mm Sintered Rotor	1
LRP50634	X-12 13.0mm Sintered Rotor	1
LRP50635	X-12 Stock Spec Rotor 12.45mm	1
LRP50636	Works Team X-12 12.0mm Rotor	1
LRP50637	Works Team X-12 12.5mm Rotor	1
LRP50638	Works Team X-12 13.0mm Rotor	1
LRP50639	X-12 Stock Spec 1S LiPo Rotor	1
LRP62415	LRP Logo Sticker Sheet	1
LRP63541	LRP Pit Towel 2	1
LRP80135	BEC Stabilizing Capacitor	1
LRP82512	SXX Low Profile Fan	1
LRP82515	30mm Motor Fan/Clamp, Gunmetal	1
LRP82520	Radical Cooling Set, Blue	1
LRP82530	SXX Power Cap 3.7-4.8V	1
LRP82531	SXX Power Cap 6.0-7.4V	1
LRP819307	70mm High Flex Sensor Wire	1
LRP819310	100mm High Flex Sensor Wire	1
LRP819315	150mm High Flex Sensor Wire	1
LRP819320	200mm High Flex Sensor Wire	1

:: Qualifier Series Vehicles

7052	Pro Lite 4x4 RTR, 1/10 Scale (ready-to-run)	1
20510	RIVAL Electric Monster Truck RTR, 1/8 Scale (ready-to-run)	1
30112	APEX Touring V-Type, 1/10 Scale (ready-to-run)	1

:: 1/18 Kits and RTR's

20103	RC18B2 - RC18T2 Team Kit	1
20121	SC18 RTR Brushless (ready-to-run)	1

:: 1/12, 1/10 Kits and RTR's

2042	Nitro TC3 RTR Plus (ready-to-run)	1
4020	FT 12R5.2 Kit	1
7025	RC10T4.2 FT Kit	1
7029	SC10 Associated/RC10.com Truck RTR (ready-to-run)	1
7030	SC10 KMC Wheels Race Truck RTR (ready-to-run)	1
7037	RC10T4.1 RTR 2.4GHz Brushless (ready-to-run)	1
7038	SC10.2 FT Kit	1
7046	SC10 RS RTR, Lucas Oil (ready-to-run)	1
7047	SC10 RS RTR, Monster Energy (ready-to-run)	1
7048	SC10 RS RTR, Pro Comp (ready-to-run)	1
7049	SC10 RS RTR, Rockstar/Makita (ready-to-run)	1
7050	SC10 RS RTR, Hart and Huntington (ready-to-run)	1
7092	GT2 RS Truck Nitro RTR (ready-to-run)	1
7093	SC10GT RTR (ready-to-run)	1
8020	FT RC10R5 Kit	1
8022	FT RC10R5.1 Kit	1
9039	RC10B4.1 RTR 2.4GHz Brushless (ready-to-run)	1
9040	FT RC10B4.1 Worlds Kit	1
9041	FT RC10B4.2 Kit	1
9050	SC10B RS RTR (ready-to-run)	1
9062	FT B44.2 4WD Buggy Kit	1
30101	TC4 Club Racer 4WD Touring Car Race Roller	1
30108	FT TC6.1 WC 4WD Touring Car Kit	1
90004	SC10 4x4 Kit	1
90005	SC10 4x4 Lucas Oil RTR (ready-to-run)	1
90006	SC10 4x4 Pro Comp RTR (ready-to-run)	1
90007	SC10 4x4 Rockstar/Makita RTR (ready-to-run)	1
90010	SC10 4x4 FT Kit	1

:: 1/8 Kits and RTR's

20501	MGT 4.60 SE RTR (ready-to-run)	1
20502	MGT 8.0 Nitro RTR (ready-to-run)	1
20503	Limited Edition MGT 4.60 Nitro RTR, w/flag body (ready-to-run)	1
20504	Limited Edition MGT 8.0 Nitro RTR, w/flag body (ready-to-run)	1
80905	RC8RS "Race Spec" Nitro Buggy RTR (ready-to-run)	1
80906	RC8.2 Nitro Buggy FT Kit	1
80907	RC8.2e Electric Buggy FT Kit	1
80908	RC8.2e Electric Buggy RTR (ready-to-run)	1
80912	RC8T Championship Edition	1
80933	SC8.2e Short Course Race Truck, Rockstar/Makita Electric RTR (ready-to-run)	1
80934	SC8.2e Short Course Race Truck, Slick Mist Electric RTR (ready-to-run)	1

:: Lubes & Adhesives / Decals / Misc.

1105	FT Green Slime Shock Lube	1
1596	FT Locking Adhesive	1
1597	FT Tire Adhesive, medium	1
6588	Black Grease - 4cc	1
6591	S.Diff Lube - 4cc	1
6636	Silicone Grease - 4cc	1
6727	Servo Tape	2
716	Reedy 2009 Sticker Set	1
3816	American Bumper Sticker	1
3820	AE Logo Decal Sheet	1
3834	AE Blue Embossed Logo Sticker	2



:: RePlay Cameras

RP001	Replay XD1080 Complete Camera System	1
RP002	Replay XD720 Complete Camera System	1
RP021	Replay XD1080 Lens Bezel Kit	1
RP022	Replay XD1080 Clear Lens Cover	1
RP023	Replay XD1080 Lens Bezel & Rear Cap O-Ring	1
RP029	Replay XD1080 HDMI to Mini-HDMI	1
RP030	Replay XD1080 Mini 8-pin USB Charge Data Cable	1
RP032	USB DC Car Charger 1A Stubby	1
RP033	USB DC Car Charger 500mAh	1
RP034	Micro SDHC USB Reader	1
RP036	3M VHB 4991 Mount Adhesive for SnapTray	1
RP037	3M VHB 5962 Mount Adhesive for Pro Flat Mount	1
RP038	3M VHB 5962 Mount Adhesive for SnapTray	1
RP041	Replay XD Suction Cup Arm Mini Clamp	1
RP042	Replay XD Suction Cup Short Arm Base	1
RP043	Replay XD Skateboard Mount	1
RP044	Replay XD VHB SnapTray, Convex	1
RP045	Replay XD VHB SnapTray, Flat	1
RP046	Au Plug for Universal DC Wall Charger	1
RP047	Eu Plug for Universal DC Wall Charger	1
RP048	Uk Plug for Universal DC Wall Charger	1
RP049	Universal USB DC Wall Charger 1A	1
RP054	Replay ReView Field Monitor	1

:: Tools

1111	FT Turnbuckle Wrench	1
1113	12mm Big Bore Shock Tool	1
1449	FT Off Road Ride Height Gauge	1
1541	FT Hex Driver Set, (7 pcs)	1
1542	FT .050" Silver Hex Driver	1
1543	FT 1/16" Black Hex Driver	1
1544	FT 1.5mm Purple Hex Driver	1
1545	FT 5/64" Blue Hex Driver	1
1546	FT 3/32" Gold Hex Driver	1
1547	FT 2.5mm Green Hex Driver	1
1548	FT 3mm Red Hex Driver	1
1551	FT Screwdriver Set	1
1553	FT Phillips Silver Screwdriver	1
1554	FT Silver Spring Hook Tool	1
1561	FT Nut Driver Set, (6 pcs)	1
1562	FT 3/16" Black Nut Driver	1
1563	FT 1/4" Red Nut Driver	1
1564	FT 5.5mm Red Nut Driver	1
1565	FT 11/32" Green Nut Driver	1
1567	FT 8mm Gold Nut Driver	1
1589	FT 5/64" Blue Ball Hex Driver	1
1590	FT 3/32" Gold Ball Hex Driver	1
1592	FT Ball Hex Driver Set, (3 pcs)	1
1655	FT 8-Piece 1/4" Hex Drive Set	1
1656	FT 1/4" Hex Drive Handle, without tips	1
1657	FT 1/4" Hex Drive .050" Tip	1
1658	FT 1/4" Hex Drive 1/16" Tip	1
1659	FT 1/4" Hex Drive 5/64" - 2.0mm Tip	1
1660	FT 1/4" Hex Drive 3/32" Tip	1
1661	FT 1/4" Hex Drive 1.5mm Tip	1
1662	FT 1/4" Hex Drive 2.5mm Tip	1
1663	FT 1/4" Hex Drive 3/16" Nut Driver Tip	1
1664	FT 1/4" Hex Drive 1/4" Nut Driver Tip	1
1665	FT 1/4" Hex Drive 11/32" Nut Driver Tip	1
1666	FT 1/4" Hex Drive 5.5mm Nut Driver Tip	1
1667	FT 1/4" Hex Drive 7.0mm Nut Driver Tip	1
1668	FT 1/4" Hex Drive 8.0mm Nut Driver Tip	1
1669	FT 1/4" Hex Drive 5/64" - 2.0mm Ball End Tip	1
1670	FT 1/4" Hex Drive 3/32" Ball End Tip	1
1671	FT 1/4" Hex Drive Standard Screwdriver Tip	1
1672	FT 1/4" Hex Drive Phillips Screwdriver Tip	1
1673	FT 1/4" Hex Drive 2.5mm Ball End Tip	1
1674	FT 1/4" 5 Piece Power Tool Tips Set (5/64-2.0mm, 1.5mm, 2.5mm, 5/64"- 2.0mm ball, 2.5mm ball)	1
1719	FT Camber + Track Width Tool	1
1737	FT Body Scissors	1
3718	12 Inch Nylon Wire Ties	12
3719	6 Inch Nylon Wire Ties	12
3720	8 Inch Nylon Wire Ties	12
3987	FT Droop Gauge	1
6429	Shock Building Tool	1
6956	Molded Tools, Set	1
7494	V2 Stamped Multi-tool	1
7709	4 Inch Nylon Wire Ties	12

:: Apparel

SP35**	Reedy 09' White T-Shirt (L, XL, 2XL)	1
SP36**	Reedy 09' Black T-Shirt (M, L, XL, 2XL, 3XL)	1
SP37**	Reedy 2012 T-shirt - Black (S, M, L, XL, 2XL, 3XL)	1
SP38	Reedy Trucker Hat	1
SP39	Reedy Patch	1
SP66**	Stencil Blue T-Shirt (S, M, L, XL, 2-6XL)	1
SP67**	AE Stencil Gray Sweatshirt (S, M, L, XL, 2XL, 3XL)	1
SP68**	AE Stencil Blue T-Shirt (M, L, XL)	1
SP69**	AE 26 Time World Championship T-Shirt, Black (S, M, L, XL, 2XL, 3XL)	1
SP70**	Associated Windbreaker (S, M, L, XL, 3XL)	1
SP71**	Associated Winter Jacket (S, M, L, XL, 2XL)	1
SP73**	AE Long Sleeve T-Shirt (S, M, L, XL, 2XL)	1
SP74**	AE White T-Shirt (S, M, L, XL, 2XL, 3XL, 4XL)	1
SP75**	AE Blue T-Shirt (S, M, L, XL, 2-6XL)	1
SP76**	AE Black T-Shirt (S, M, L, XL, 2XL, 3XL, 4XL)	1
SP77**	AE 2012 T-Shirt, Blue (S, M, L, XL, 2XL, 3XL)	1
SP78**	AE 2012 T-Shirt, White (S, M, L, XL, 2XL, 3XL)	1
SP79**	AE 2012 T-Shirt, Black (S, M, L, XL, 2XL, 3XL)	1
SP84**	Reedy 3D T-Shirt, Black (S, M, L, XL, 2XL, 3XL)	1
SP85**	Reedy Zip Hoodie, Black (S, M, L, XL, 2XL, 3XL)	1
SP86**	Reedy Girl's 3D T-Shirt, Black (S, M, L, XL)	1
SP102	Outer & Inner Boxes, for #SP-416	1
SP103	Inner Boxes only, for #SP416	1
SP411S	AE Hat 11' Flat Bill Black S/M	1
SP411L	AE Hat 11' Flat Bill Black L/XL	1
SP413S	26 Time World Championship Hat S/M	1
SP413L	26 Time World Championship Hat L/XL	1
SP416	Associated Car Carrier Bag, Medium	1
SP417	1/10 FT Motor Bag	1
SP418	Factory Team 1/10 Car Carrier Bag	1
SP420**	AE Pit Gloves (M, L, XL)	Pr.
SP421S	AE 2012 Hat, Black, Flat Bill, S/M	1
SP421L	AE 2012 Hat, Black, Flat Bill, L/XL	1
SP422S	AE 2012 Hat, Black, Curved Bill, S/M	1
SP422L	AE 2012 Hat, Black, Curved Bill, L/XL	1
SP423S	AE 2012 Hat, White, Flat Bill, S/M	1
SP423L	AE 2012 Hat, White, Flat Bill, L/XL	1
SP424S	AE 2012 Hat, White, Curved Bill, S/M	1
SP424L	AE 2012 Hat, White, Curved Bill, L/XL	1
715	Reedy 2009 Track Banner	1
110684	Team Associated Track Banner	1

Associated Electrics, Inc.
26021 Commercentre Drive
Lake Forest, CA 92630-8853 USA
<http://www.TeamAssociated.com>
<http://www.RC10.com>
[http://twitter/Team Associated](http://twitter/TeamAssociated)
<http://bit.ly/AEonFacebook>

call: (949) 544-7500

fax: (949) 544-7501

Check out the following web sites for all of our electric kits, current products, new releases, setup help, tips, and racing info!

www.TeamAssociated.com. - www.RC10.com

:: Notes

A large, empty rectangular area intended for taking notes, framed by a thin black border.

:: Notes

A large, empty rectangular area intended for taking notes, framed by a thin black border.

Front Suspension

Camber: -1°
Toe: 0°

2mm Washers: 2mm

Ride Height: 30mm

Steering Rack: Front Back

Washers: 2mm

Caster Block Spacing: Forward Back

Caster: 20° 25° 30°

Rear Suspension

Camber: -1°
Inner Toe: 3°
Anti-Squat: 2°

Washers: 1mm

Chassis Brace Ground Flat:

Ride Height: 28mm

Wheelbase: Long Medium Short

Rear Hub Carriers: 0° 0.5° 1° 1.5°

Aluminum Hub Tower: A B C

Anti Roll Bar: None Black (soft) Silver (med) Gold (hard)

Front Shocks

Spring: Gray Piston: 1.6
 Shock Oil: 35wt Limiter: 4

Rear Shocks

Spring: White Piston: 1.7
 Shock Oil: 35wt Limiter: 2

Electronics / Weight

Motor & Wind: _____
Pinion: _____ **Spur Gear:** _____
Batteries: _____
Battery Placement: _____
Ballast Weight: _____
Chassis Weight: _____

Radio: _____
Throttle / Brake e.p.a.: _____
Throttle / Brake expo: _____
Servo: _____ **Steering Expo:** _____
ESC: _____
ESC Settings: _____

Front Tires

Tire: _____
Compound: _____
Insert: _____ **Wheel:** _____

Rear Tires

Tire: _____
Compound: _____
Insert: _____ **Wheel:** _____

Drivetrain

Slipper: VTS
 2 Pads 3 Pads 4 Pads
 Notes: _____

Differentials

Ball:
Gear:
 Notes: Tight

Other

Body Type: _____
Wing Type: _____ **Wing Angle:** _____
Track Info















Race and Vehicle Comments

Qualify: _____ **Main:** _____ **Finish:** _____ **TQ:** _____
Comments: _____





Surface:	Traction:	Conditions:	Moisture:
Dirt <input type="checkbox"/>	Low <input type="checkbox"/>	Grooved <input type="checkbox"/>	Wet <input type="checkbox"/>
Carpets <input type="checkbox"/>	Med <input type="checkbox"/>	Dusty <input type="checkbox"/>	Damp <input type="checkbox"/>
Astro <input type="checkbox"/>	High <input type="checkbox"/>	Smooth <input type="checkbox"/>	Dry <input type="checkbox"/>
Multi <input type="checkbox"/>		Bumpy <input type="checkbox"/>	
		Hard Pack <input type="checkbox"/>	
		Loamy <input type="checkbox"/>	

:: Hardware - 1:1 Scale View





Cap Head (shcs)

-  **2-56x 3/16 (9898)**
-  **4-40x1/4 (6285)**
-  **4-40x5/16" (6932)**
(4145, aluminum)
-  **4-40x3/8 (6924)**
w/hole (6929)
-  **4-40x1/2 (6925)**
-  **4-40x5/8 (6926)**
-  **4-40x3/4 (6927)**
-  **4-40x7/8 (7738)**
-  **4-40x1 (6928)**
-  **4-40x1 1/4 (6913)**
-  **4-40x1 3/4 (9833)**
-  **5-40x7/16 (9643)**
-  **5-40x9/16 (9644)**
-  **5-40x7/3/4 (9835)**





Flat Head (fhcs)

-  **4-40x3/8 (6292)**
-  **4-40x1/2 (6922)**
-  **4-40x5/8 (6915)**
-  **5-40x1/2 (9269)**

Shims and Washers

-  **.030 Ballstud Washer (9630)**
-  **.030 Nylon Spacer (4187)**
-  **Servo Mount Washer (7337)**
-  **#4 Washer (6936)**
-  **3/16 Axle Shim - Silver (7368)**
-  **FT Ballstud Washer, Aluminum**
(1mm and 2mm, 4 each) (31286)









Ball Bearings

-  **Steering Rack Bearing**
(3971)
-  **3/16x3/8 (3977)**
-  **3/16x1/2 RS (7935)**
-  **10 x 16mm (9832)**





Ballstuds

-  **Black .20 Short (3981)**
-  **Black .30 Short (3983)**
-  **Silver .20 Short (6276)**
-  **Silver .30 Long (6277)**
-  **Silver .40 (6278)**

Button Head (bhcs)

-  **2-56x1/8 (9645)**
-  **2-56x5/16 (4334)**
-  **4-40x1/4 (6288)**
-  **4-40x5/16 (6919)**
-  **4-40x3/8 (6917)**
-  **4-40x7/16 (2221)**
-  **4-40x3/4 (7413)**
-  **4-40x7/8 (91311)**
-  **3x8mm (31532)**

Nuts (lock/plain)

-  **4-40 Aluminum Locknut (4449)**
-  **4-40 Plastic Nut (6472)**
-  **5-40 Diff Locknut (6629)**
-  **8-32 LP Steel Locknut (6953)**
-  **8-32 Steel Locknut (6952)**

Clips

-  **E-clip 1/8 (6299)**

Diff Balls

-  **5/64 Diff Thrust Balls (6574)**
-  **3/32 Carbide Diff Balls (6581)**

* Not all servo's are listed
 * Make sure servo linkage clears the servo through full travel in both directions.
 Use #7336 servo spacers to adjust the servos position (to make the steering link as straight as possible)

Steering Servo Chart

		# 9180 servo arm 
Associated	XP-1015, XP-1313	F
Airtronics	94102	A
Airtronics	94257, 94258, 94357, 94358, 94452, 94453, 94755	A
Hitec	HS-5625MG, HS-5645MG, HS645MG	H
Hitec	HS-965, HS-985MG, HS-5965, HS-5985MG	H
JR	Z4750, Z2750	J
JR	Z250, Z550	J
Futaba	S9204, S9250, S9450	F
Futaba	S9404	F
KO	PS-401, PS-2001, PS-2004, PS-2015, PS-2173, PS-2174, PS-2123, PS-2143, PS-2144	J

Front Suspension

Camber: _____

Toe: _____

Washers: _____

Ride Height: _____

Steering Rack: Front Back

Washers: _____

Caster Block Spacing: Forward Back

Caster: 20° 25° 30°

Rear Suspension

Camber: _____

Inner Toe: _____

Anti-Squat: _____

Washers: _____

Chassis Brace Ground Flat:

Ride Height: _____

Wheelbase: Long Medium Short

Rear Hub Carriers: 0° 0.5° 1° 1.5°

Aluminum Hub Tower: A B C

Anti Roll Bar: None Black (soft) Silver (med) Gold (hard)

Front Shocks

Spring: _____ **Piston:** _____

Shock Oil: _____ **Limiters:** _____

Rear Shocks

Spring: _____ **Piston:** _____

Shock Oil: _____ **Limiters:** _____

Electronics / Weight

Motor & Wind: _____

Pinion: _____ **Spur Gear:** _____

Batteries: _____

Battery Placement: _____

Ballast Weight: _____

Chassis Weight: _____

Radio: _____

Throttle / Brake e.p.a.: _____

Throttle / Brake expo: _____

Servo: _____ **Steering Expo:** _____

ESC: _____

ESC Settings: _____

Front Tires

Tire: _____

Compound: _____

Insert: _____ **Wheel:** _____

Rear Tires

Tire: _____

Compound: _____

Insert: _____ **Wheel:** _____

Drivetrain

Slipper: _____

2 Pads **3 Pads** **4 Pads**

Notes: _____

Differentials

Ball:

Gear:

Notes: _____

Other

Body Type: _____

Wing Type: _____ **Wing Angle:** _____

Track Info

Race and Vehicle Comments

Qualify: _____ **Main:** _____ **Finish:** _____ **TQ:** _____

Comments: _____

Surface:	Traction:	Conditions:	Moisture:
Dirt <input type="checkbox"/>	Low <input type="checkbox"/>	Grooved <input type="checkbox"/>	Wet <input type="checkbox"/>
Carpet <input type="checkbox"/>	Med <input type="checkbox"/>	Dusty <input type="checkbox"/>	Damp <input type="checkbox"/>
Astro <input type="checkbox"/>	High <input type="checkbox"/>	Smooth <input type="checkbox"/>	Dry <input type="checkbox"/>
Multi <input type="checkbox"/>		Bumpy <input type="checkbox"/>	
		Hard Pack <input type="checkbox"/>	
		Loamy <input type="checkbox"/>	



**Associated Electrics, Inc.
26021 Commercentre Dr.
Lake Forest, CA 92630 USA**

<http://www.TeamAssociated.com>

<https://www.RC10.com>

https://twitter/Team_Associated

<https://bit.ly/AEonFacebook>

call: (949) 544-7500 - fax: (949) 544-7501

**Check out the following web sites for all of our kits,
current products, new releases, setup help, tips, and racing info!
www.TeamAssociated.com - www.RC10.com**