

For Immediate Release: February 2025

RC8T4e Team Kit with Gearbox Upgrade

#80952



ELECTRIC ■ OFF ROAD ■ 1:8 SCALE ■ 4 WHEEL DRIVE ■ KIT

New RC8T4 series Gearbox Upgrade!

1:8 scale truck is the R/C hobby's highest stress discipline; Associated Electrics' Area 51 created a new gearbox upgrade to absolutely bulletproof the RC8T4 drivetrain. The new upgraded 40/9 ring and pinion are completely re-designed with massive teeth which allow for more tooth engagement and prevent skipping. In addition, the RC8B4 front and rear gearboxes are updated for the tightest possible screw and bearing fit using high stiffness polymer.

Team Associated driver Spencer Rivkin used the new parts win the 2024 ROAR Electric Truck National Title with his RC8T4e, never having to worry about the durability of his truck gearboxes while he pushed it to the max on track.

Legacy RC8T4 Features

- RC8T4e chassis layout featuring two saddle pack-style battery configurations. Both configurations include a centrally mounted center differential and in-line center driveshafts for superior drivetrain efficiency and equalized chassis balance.
- Four battery configurations to choose from: --Two 2S shorty LiPo batteries for lowest CG and exceptional weight bias --Two full size "saddle pack" LiPo batteries for lowest CG and exceptional weight bias --One 4S shorty LiPo battery for simplified setup and more centralized weight bias --One full size LiPo battery for simplified setup and more centralized weight bias.
- Innovative front-end geometry with new 8° steering blocks are paired with a new wider upper suspension arm pivot for improved steering balance and predictable handling in all conditions.
- RC8T4e gearboxes are specific to front and rear with larger bearing sizes resulting in longer life of ring and pinion gears: Front gearbox is a 3.5° inclined pinion gear angle to straighten the center driveshaft for increased drivetrain efficiency and reduced phasing and vibration. Rear gearbox is a 0° pinion gear angle and a center mounted rear chassis brace.
- V2 front shock tower design with updated suspension geometry and body mount positions for all styles of truck bodies.
- Front and rear center dogbone driveshafts for improved drivetrain efficiency and durability.
- Front upper suspension arm updated to have bushing insert for improved fitment and performance.
- RC8B4 rear wing mount has adjustable wing angle shims, significant strength improvements, an aerodynamic shape, and extra clearance for shock position adjustment.
- The adjustable rear wing has more vertical fins for increased straight-line stability, a taller rear lip height for increased downforce, and increased strength in various areas to reduce bending fatigue.
- RC8B4 rear chassis brace is mounted centrally to the gearbox, which reduces material fatigue, centralizes shear forces, and improves the life of rear-end drivetrain parts. There are three different chassis flex options using two chassis hole mounting locations and an optional turnbuckle ball for flex in more degrees of freedom.
- +2 mm and +4 mm shock rod ends for finer adjustment of droop and up-travel settings.
- 35.5 mm front and 44.5 mm rear shock shafts for improved dampening
- RC8B4 rear hub features a symmetrical left and right common design with axle height inserts for adjustable roll center tuning options.
- +2° steering block arm.
- V3 differentials with HTC gear sets.
- RC8T3.2 split center diff mounts with aluminum center top plate.

- 16mm shocks equipped with improved material locking spring cups and rod ends, V2 springs, “stiff” style shock bladder, combination bleeder/emulsion caps, and blue aluminum threaded collars.
- RC8B3.2 narrow C and D arm mounts.

HIGHLIGHTS



Wing has vertical rear fins and a taller rear lip for increased straight-line stability and down-force



Wing mount features adjustable wing angle shims, strength improvements, and aerodynamic strength



New rear chassis brace is mounted centrally to the gearbox, which reduces material fatigue



New front and rear gearbox designs are engineered for better drivetrain efficiency



Chassis layout featuring saddle pack-style battery configurations: Two 2S shorty or one 4S shorty

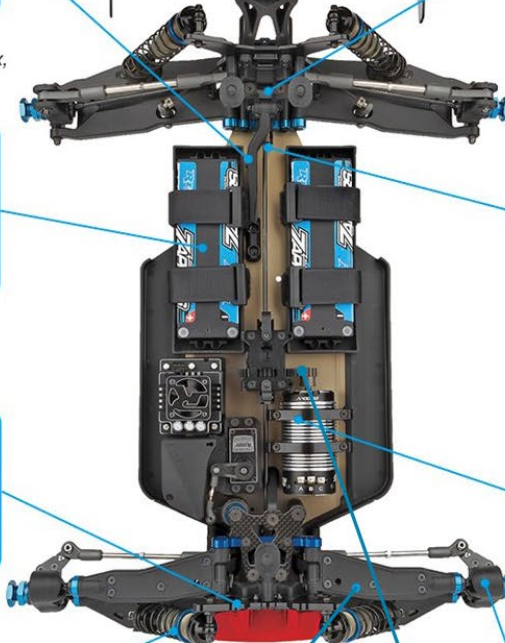

Front and rear center dogbone driveshafts for improved drivetrain efficiency and durability



New front shock tower design and body mount positions for all styles of truck bodies



New two-piece clamping motor mounts make for easy and secure gear mesh adjustments



16mm shocks equipped with improved material locking spring cups and rod ends



Front upper suspension arms updated to have bushing insert for improved fit and performance



New 40/9 gear set for optimal torque and acceleration



Innovative front-end geometry with new 8° steering blocks

Due to ongoing R&D, photos may not match final kit. Vehicle shown equipped with items NOT included in kit: All electronics, pinion gear, body, wheels, and tires. Assembly and painting required.

NOTABLE RC8 WINS

2009	Ryan Maifield	RC8T	R.O.A.R. 1:8 Fuel Off-Road National Champ
2010	Ryan Maifield	RC8Be	R.O.A.R. 1:8 Elec Off-Road National Champ
2011	Ryan Maifield	RC8T	R.O.A.R. 1:8 Fuel Off-Road National Champ
2011	Ryan Cavalieri	RC8B	R.O.A.R. 1:8 Fuel Off-Road National Champ
2015	Ryan Cavalieri	RC8B3 Prototype	Neo-X 1:8 Fuel Off-Road Champ
2016	Spencer Rivkin	RC8B3	R.O.A.R. 1:8 Fuel Off-Road Nationals
2016	Spencer Rivkin	RC8T3e	R.O.A.R. 1:8 Elec Off-Road National Champ
2017	Kyle McBride	RC8B3.1	AARCMCC Australian National Title, SDMCC
2017	Davide Ongaro	RC8B3.1	Neo17 1:8 Fuel Off-Road Championship
2018	Davide Ongaro	RC8B3.1	I.F.M.A.R. World Championship
2019	Spencer Rivkin	RC8B3.1	A-Main Hobbies Mfgs Cup Pro Nitro Buggy
2019	Spencer Rivkin	RC8B3.1e	A-Main Hobbies Mfgs Cup Pro Elec Buggy
2019	Spencer Rivkin	RC8B3.1	R.O.A.R. 1:8 Fuel Off-Road Nationals
2019	Davide Ongaro	RC8B3.1	RCGP Series Championship
2019	Davide Ongaro	RC8B3.1	Italian 1:8 Nitro Championship
2020	Cole Tollard	RC8B3.1e & RC8T3.1e	Motorama
2021	Spencer Rivkin	RC8T3.2 & RC8B3.2e	Psycho Nitro Blast
2021	Davide Ongaro	RC8B3.2 & RC8B3.2e	Buggyland 8.0
2021	Davide Ongaro	RC8B3.2	iBuggy Challenge
2022	Davide Ongaro	RC8B4	I.F.M.A.R. World Championship
2024	Davide Ongaro	RC8B4.1	I.F.M.A.R. World Championship
2024	Spencer Rivkin	RC8T4e	R.O.A.R. 1:8 Elec Off-Road National Champ



SPECIFICATIONS

Scale	1:8
Power	Electric
Length	560mm (22.05")
Width	Varies
Weight	Varies
Wheelbase	Varies

ITEMS NEEDED TO COMPLETE

- 1:8 scale electric motor and speed control
- LiPo battery
- Battery charger (suited for the battery mentioned above)
- 2-channel surface transmitter
- 2-channel receiver
- Steering servo
- Pinion gear
- 1:8 Body
- Wheels and tires
- Lexan® specific spray paint for body
- 1:8 scale off-road wheels and tires
- 4x AA batteries
- Other helpful items: Silicone Shock Fluid, Silicone Diff Fluid, Body Scissors (#1737), Reamer / Hole Punch, FT Wrench Set (#1519), Hobby Knife, Needle Nose Pliers, Wire Cutters, Soldering Iron, Calipers or a Precision Ruler

COO: Taiwan

Pieces per case: 4

Comp SKU: 80948

CATALOG INFORMATION

UPC	Part No.	Description	MSRP	MAP	Available
784695809529	80952	RC8T4e Team Kit with Gearbox Upgrade	\$1,009.99	\$685.99	February 2025



21062 Bake Pkwy
Lake Forest CA 92630
www.AssociatedElectrics.com



Download all zipped photos here: <https://tinyurl.com/4xjvtaf5> (6.7MB) Link is active for 30 days.