

## Front Suspension:

RESET

**Ride Height:** 37 mm (Body On + Full Tank)

**Toe:** Tierod Gap = 61.1 mm **Hex:** #81319 11.5 mm (Kit)

**Anti-Roll Bar**

**Size:** 2.2 mm

**Gap:** 2 mm

**Ackerman**

1 2 3

**Steering Arm Plate:** #81063 +2 (Kit)

**Drive Shaft:** CVAs:  Universals:

**Notes:**

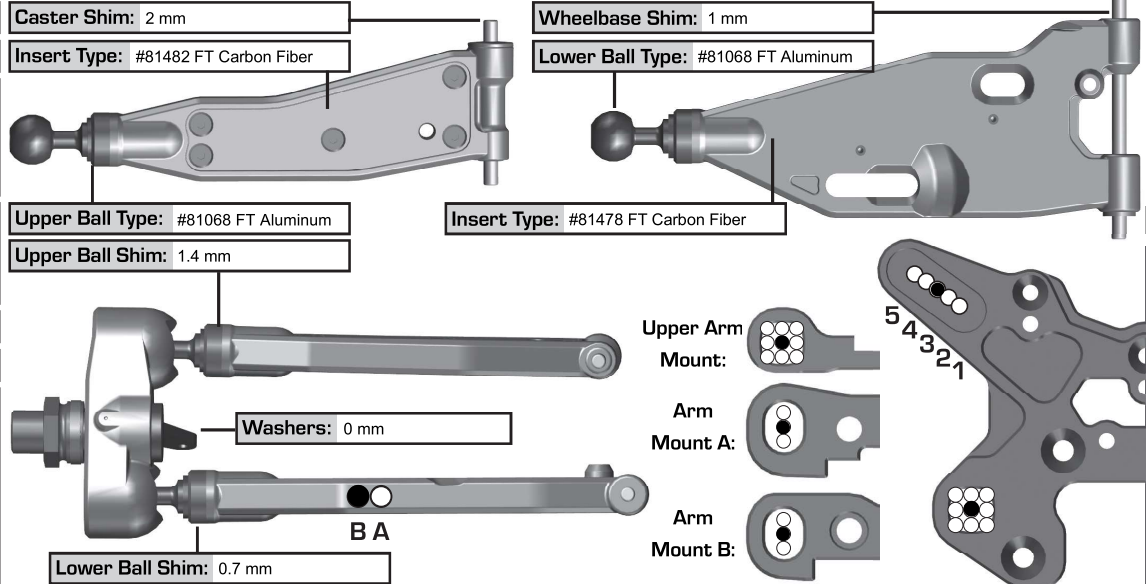

## Rear Suspension:

**Ride Height:** 42 mm (Body On + Full Tank)

**Camber:** -1° **Hex:** #81319 11.5 mm (Kit)

**Anti-Roll Bar**

**Size:** 2.5 mm

**Gap:** 2 mm

**Drive Shaft:** CVAs:  Universals:

**Chassis Brace**

**Pivot Type:** Kit

**Insert Type:** Kit

**Notes:** #81489 FT Rear Hubs, Aluminum

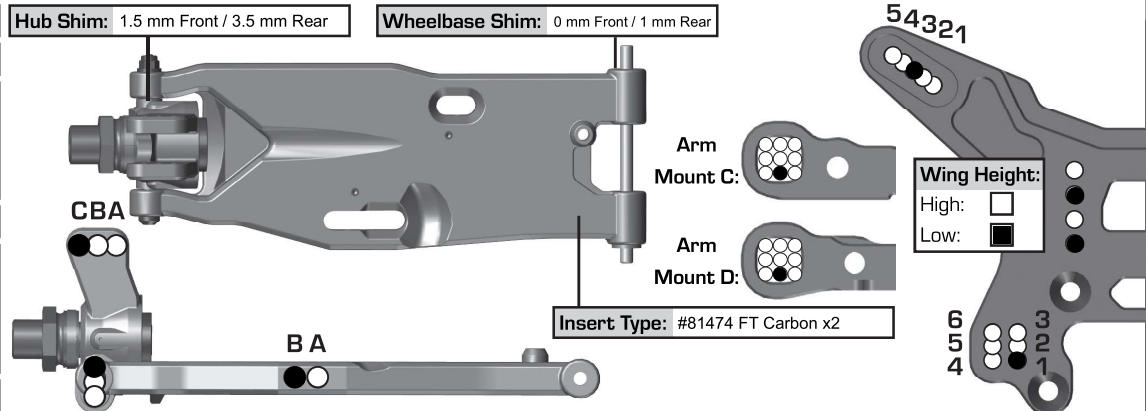

## Electronics and Engine:

**Radio:** Sanwa M17

**Receiver Battery:** #27313 Reedy 2400 mAh

**Throttle Servo:** #27153 Reedy RT5012A

**Steering Servo:** #27153 Reedy RT5012A

**EPA:** Throttle: % Brake: %

**Brake Bias:** 40%F / 60%R **D/R:** 100 %

**Engine:** O.S. AD2 **Temp:** N/A

**Pipe:** O.S. 2100 **Fuel:** VP Powermaster Race 30%

**Restrictor:** 7 mm **Glow Plug:** O.S. P3 Gold

**Notes:**

## Differential:

	Front	Center	Rear
<b>Fluid:</b>	#5447 FT 15k	#5447 FT 15k	#5454 FT 7k
<b>Gears:</b>	HTC	HTC	HTC
<b>Mass:</b>	N/A	N/A	N/A
<b>Notes:</b>			

## Clutch and Gearing:

**Spur Gear:** 46T **Bell:** 13T

**Shoes:** 2 x #81377 Hard Plastic + 2 x #81375 Hard Aluminum

**Springs:** 2 x #81366 0.95 + 2 x #81367 1.00

**Notes:**

## Shocks:

	Front	Rear
<b>Piston:</b>	#81200 6 x 1.3 Flat	#81200 6 x 1.3 Tapered
<b>Fluid:</b>	#5433 FT 37.5 wt	#5432 FT 32.5 wt
<b>Bladder:</b>	#81184 Bleeder	#81184 Bleeder
<b>Rebound:</b>	None	None
<b>Spring:</b>	#81226 Yellow	#81237 Red
<b>Length:</b>	105.5 mm	125.5 mm
<b>Eyelet:</b>	+2	+2
<b>Notes:</b>		

## Track Info:

**Size:** Small  Medium  Large  Extra Large

**Surface:** Dirt  Carpet  AstroTurf  Multi Surface

**Traction:** Low  Medium  High  Very High

**Moisture:** Dry  Damp  Wet

**Condition:** Indoor  Outdoor  Dusty  Hard Packed

Bumpy  Grooved  Smooth  Loamy

**Temperature:** Ambient: 60F Track: 60F

**Notes:**

## Tires:

**Front Tire/Compound/Insert/Wheel:**

JConcepts Reflex / Green / JConcepts Dirt Tech / JConcepts Mono

**Rear Tire/Compound/Insert/Wheel:**

JConcepts Reflex / Green / JConcepts Dirt Tech / JConcepts Mono

**Notes:**

**Radio Tray Flex Assembly:**

**Transponder Mount:**  None:

**Radio Tray Brace:**

## Body and Wing:

**Body:** JConcepts F2

**Rear Wing:** JConcepts Razor

**Angle:** 0°  2°  4°  **Button:** Flat  Fin

**Vent Holes:**

**Weight:**

**Total Weight:**

**Notes:**

## Vehicle Comments:

**Notes:**