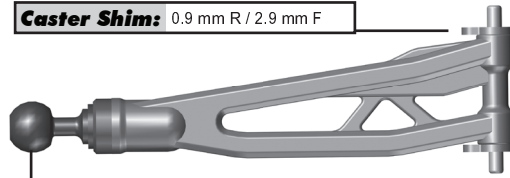
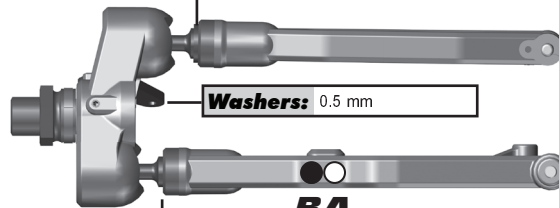

Front Suspension:

Ride Height: 36 mm (Body Off & Full Tank)
Camber: -2
Toe: +1 (Tiered Gap = 61.0 mm)
Anti-Roll Bar
Size: 2.5 mm (White)
Gap: 2 mm
Ackerman
Notes: #81066 Steering Block Arms
Drive Shaft: CVAs: <input type="checkbox"/> Universals: <input checked="" type="checkbox"/>
Chassis Brace: Short: <input type="checkbox"/> Long: <input checked="" type="checkbox"/>
Hex: #81080 RC8B3 Wheel Hexes, +2mm wide
Notes: 1mm Removed From Front A-Arm; 2mm Shim Between Sway Bar Links.

Caster Shim: 0.9 mm R / 2.9 mm F

Upper Ball Type: #81068 Aluminum

Upper Ball Shim: 0

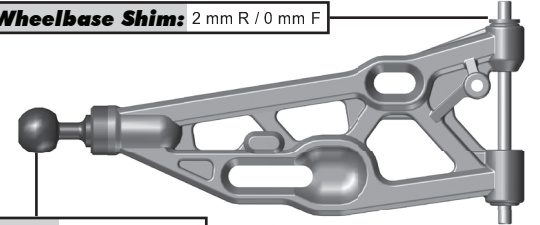
Washers: 0.5 mm

BA
Lower Ball Shim: 1.40 mm (Thick)

Wheelbase Shim: 2 mm R / 0 mm F

Lower Ball Type: #81068 Aluminum

Upper Arm Mount:
Arm Mount A:
Arm Mount B:

Rear Suspension:

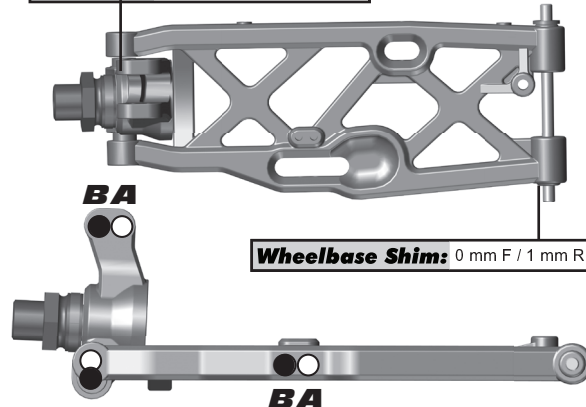
Ride Height: 40 mm (Body Off & Full Tank)
Camber: -2.5°
Anti-Roll Bar
Size: 2.9 mm (Red)
Gap: 0 mm
Drive Shaft: CVAs: <input type="checkbox"/> Universals: <input checked="" type="checkbox"/>
Chassis Brace: Short: <input type="checkbox"/> Long: <input checked="" type="checkbox"/>
Hex: #81319 Hex Drive, 17mm Offset
Notes: #81077 FT Aluminum Hubs

Hub Shim: 2.5 mm F / 2.5 mm R

BA
Wheelbase Shim: 0 mm F / 1 mm R

BA
Arm Mount C:
Arm Mount D:

Electronics and Engine:

Radio: Sanwa M12S
Receiver Battery: #315 Reedy 2100 mAh
Throttle Servo: #27107 Reedy RT2207A
Steering Servo: #27107 Reedy RT2207A
EPA: Throttle: 65 % Brake: 90 %
Brake Bias: 50% F / 50% R D/R: 100 %
Engine: Novarossi Mito 7 Temp: N/A
Muffler: Novarossi 9901 Fuel: VP Powermaster 30%
Restrictor: 7 mm Glow Plug: P5

Differential Fluid:

Front: 7,000
Center: 10,000
Rear: 7,000
Notes:

Clutch and Gearing:

Spur Gear: 46T	Bell: 13T
Shoes: 4 x #81375 Hard Aluminum	
Springs: 4 x #81367 1.00 mm	
Notes: RC8B3.1 4-Shoe Clutch	

Shocks:

	Front	Rear
Piston:	6 x 1.3 Flat	6 x 1.3 Flat
Fluid:	40 wt	32.5 wt
Cap:	#81180 Bladder	#81180 Bladder
Rebound:	0	0
Spring:	Mugen 75/7.75 Silver	HB Orange
Free Length:	109 mm	128 mm
Notes:	#81176 & #81177 Chrome Shock Shafts; #81407 Shock Seal Busing Set; #81164 & #81165 Fox Shock Bodies	

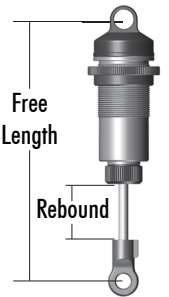

Track Info:

Size: Small <input type="checkbox"/> Medium <input checked="" type="checkbox"/> Large <input type="checkbox"/> Extra Large <input type="checkbox"/>
Surface: Dirt <input checked="" type="checkbox"/> Carpet <input type="checkbox"/> Astroturf <input type="checkbox"/> Multi Surface <input type="checkbox"/>
Traction: Low <input type="checkbox"/> Medium <input checked="" type="checkbox"/> High <input type="checkbox"/> Very High <input type="checkbox"/>
Moisture: Dry <input checked="" type="checkbox"/> Damp <input type="checkbox"/> Wet <input type="checkbox"/>
Condition: Indoor <input type="checkbox"/> Outdoor <input checked="" type="checkbox"/> Dusty <input checked="" type="checkbox"/> Hard Packed <input checked="" type="checkbox"/> Bumpy <input checked="" type="checkbox"/> Grooved <input checked="" type="checkbox"/> Smooth <input type="checkbox"/> Loamy <input type="checkbox"/>
Temperature: Ambient: _____ Track: _____
Notes:

Tires:

Front Tires: Pro-Line Blockade
Front Compound: X3
Front Insert: Pro-Line Closed Cell
Rear Tires: Pro-Line Blockade
Rear Compound: X3
Rear Insert: Pro-Line Closed Cell
Wheel (F/R): Pro-Line V2
Notes:

Body, Wings:

Body: #81324 Team Associated Kit
Wing: Pro-Line Lexan
Wing Height: High: <input type="checkbox"/> Low: <input checked="" type="checkbox"/>
Gap to Tower: In Line With Back of Rear Shocks
Weight:
Total Vehicle Weight: 4010g
Notes: 15g Under Center Rear Driveshaft

Vehicle Comments:

Notes: #81274 Upper Titanium Screw Kit; #1363 FT Aluminum Servo Horn, 18.5 mm