

Front Suspension:

RESET
Ride Height: 39mm (Tank Full, Body off)

Toe: Tierod Gap = 59.5mm **Hex:** #81319 FT 11.5 mm

Anti-Roll Bar
Size: 2.3mm

Gap: 2 mm

Ackerman

Steering Arm Plate: #81066 RC8B3 +0

Drive Shaft: CVAs: Universals:
Chassis Brace: Short: Long:
Notes: #81085 FT Aluminum Servo Saver Arm

#81495 FT Front Lower Suspension Arm, HD

#81496 FT Front Upper Suspension Arm, HD

Caster Shim: Middle

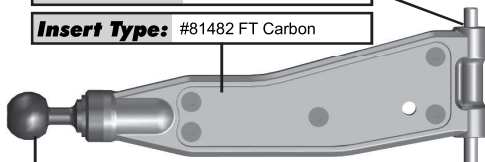
Insert Type: #81482 FT Carbon

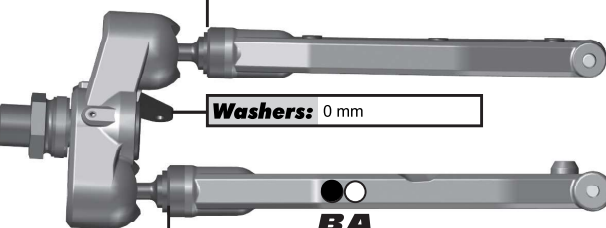
Upper Ball Type: #81068 FT Aluminum

Upper Ball Shim: 0.7 mm

Washers: 0 mm

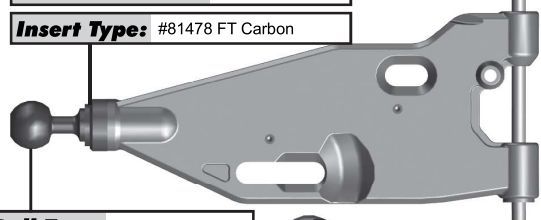
Lower Ball Shim: 1.4 mm

Wheelbase Shim: 1 mm (Arm Forward)

Insert Type: #81478 FT Carbon

Lower Ball Type: #81068 FT Aluminum

Upper
Arm
Mount:
Arm
Mount A:
Arm
Mount B:

Rear Suspension:

Ride Height: 44mm (Tank Full, Body Off)

Camber: -2 **Hex:** #81319 FT 11.5 mm

Anti-Roll Bar
Size: 2.5 mm

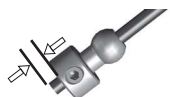
Gap: 0mm

Drive Shaft: CVAs: Universals:
Chassis Brace: Short: Long:
Notes: #81489 FT V2 Rear Hubs (+2.5, B)

#81494 FT Rear A-Arm, HD

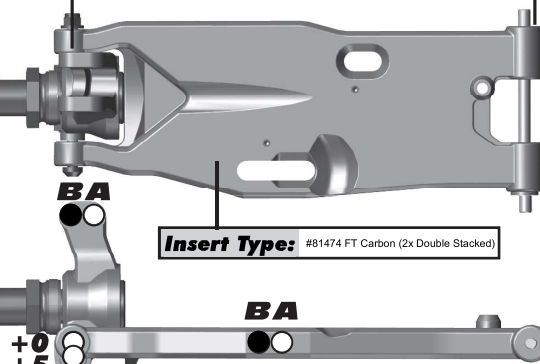
Hub Shim: Middle

Wheelbase Shim: 0 mm (Arm Forward)

Insert Type: #81474 FT Carbon (2x Double Stacked)

Arm
Mount C:
Arm
Mount D:

Electronics and Engine:

Radio: Sanwa M17

Receiver Battery: #27313 Reedy 2400

Throttle Servo: #27150 Reedy RC4020A

Steering Servo: #27150 Reedy RC4020A

EPA: Throttle: 67 % Brake: 86 %

Brake Bias: 30/70 **D/R:** 100 %

Engine: O.S. AD2 **Temp:** N/A

Muffler: O.S. 2090 **Fuel:** VP 30% Pro Race

Restrictor: 7 mm **Glow Plug:** P3

Notes:

Differential:

	Front	Center	Rear
Fluid:	#5421 FT 20K	#5421 FT 20K	#5455 FT10K
Gears:	HTC	HTC	HTC
Mass:	N/A	N/A	N/A
O-Rings:	None	None	None

Clutch and Gearing:

Spur Gear: 46 **Bell:** 13

Shoes: 4 x #81375 Aluminum, Hard

Springs: 4 x #81367 Gold (Aluminum)

Notes:

Shocks:

	Front	Rear
Piston:	#81200 6 x 1.3 Kit	3 x 1.3 + 3 x 1.4 Kit Tapered
Fluid:	#5434 FT 42.5 wt	#5434 FT 42.5 wt
Bladder:	#81453 RC8B3 Stiff	#81453 RC8B3 Stiff
Rebound:	0	0
Spring:	#81225 Blue	#81231 Blue
Length:	109 mm	130.7 mm

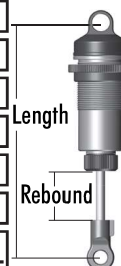

Track Info:

Size: Small Medium Large Extra Large
Surface: Dirt Carpet Astroturf Multi Surface
Traction: Low Medium High Very High
Moisture: Dry Damp Wet
Condition: Indoor Outdoor Dusty Hard Packed
 Bumpy Grooved Smooth Loamy
Temperature: Ambient: _____ Track: _____

Notes:

Tires:

Front Tire/Compound/Insert/Wheel:

JConcepts Reflex / Blue / Dirt Tech / Mono

Rear Tire/Compound/Insert/Wheel:

JConcepts Reflex / Blue / Dirt Tech / Mono

Notes: Foam Glued To The Wheel

Radio Tray Flex Assembly:

Transponder Mount: **None:**
Radio Tray Brace:

Body and Wing:

Body: Jconcepts Finisher

Wing: Jconcepts F21

Wing Height: High: Low:
Gap to Tower: 19 mm

Weight:

Total Weight: N/A

Notes:

Vehicle Comments:

Notes: #81116 FT Engine Mount Base; #81117 FT Engine Mounts; #81465 FT Gear Mesh Inserts; #81493 FT HD Gearboxes