

Front Suspension:

RESET
Ride Height: 39 mm (Body Off + Full Tank)

Toe: Tierod Gap = 62mm **Hex:** #81319 11.5 mm

Anti-Roll Bar
Size: 2.1 mm

Gap: 2 mm

Ackerman

Steering Arm Plate: #81063 +2 Deg

Drive Shaft: CVAs: Universals:
Chassis Brace: Short: Long:
Notes: #81085 Servo Saver Arm, Aluminum

#81495 FT Front Lower A-Arm, HD

#81496 FT Front Upper A-Arm, HD

#81466 FT Center Dogbone Set, Front

Caster Shim: 0.9 mm

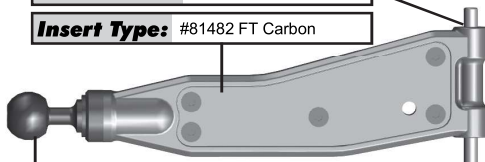
Insert Type: #81482 FT Carbon

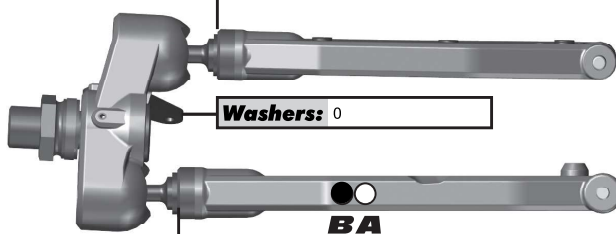
Upper Ball Type: #81068 FT Aluminum

Upper Ball Shim: 0.7 mm

Washers: 0

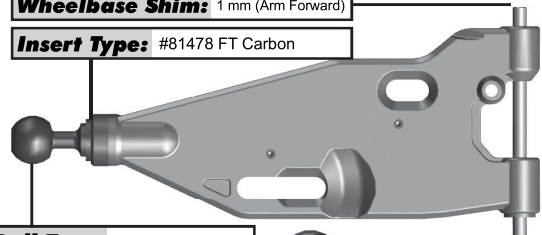
BA
Lower Ball Shim: 1.4 mm

Wheelbase Shim: 1 mm (Arm Forward)

Insert Type: #81478 FT Carbon

Lower Ball Type: #81067 Steel

Upper
Arm
Mount:

Arm
Mount A:

Arm
Mount B:

Rear Suspension:

Ride Height: 42 mm (Body Off + Full Tank)

Camber: -2° **Hex:** #81319 11.5 mm

Anti-Roll Bar
Size: 2.6 mm

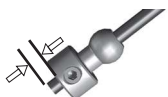
Gap: 1mm (Ball Reversed)

Drive Shaft: CVAs: Universals:
Chassis Brace: Short: Long:
Notes: #81489 FT V2 Rear Hubs (+2.5, B)

#81494 FT Rear A-Arm, HD

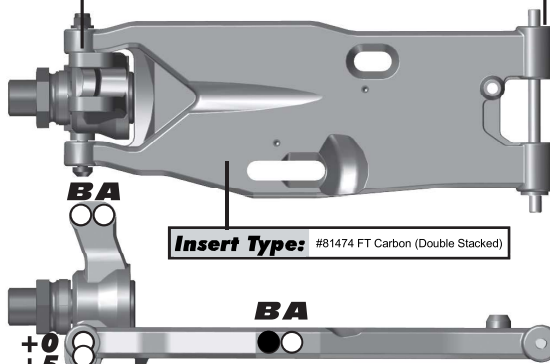
Hub Shim: Medium Back / Thick + Thin Front

Wheelbase Shim: 0 mm (Arm Forward)

BA
Insert Type: #81474 FT Carbon (Double Stacked)

BA

 +0
+5

Arm
Mount C:

Arm
Mount D:

 5
4
3
2
1

Electronics and Engine:

Radio: Futaba 7PXR

Receiver Battery: Protek

Throttle Servo: Savox 2290 Monster

Steering Servo: Savox 2290 Monster

EPA: Throttle: N/A % Brake: N/A %

Brake Bias: 50/50

D/R: 100 %

Engine: MX

Temp: N/A

Muffler: O.S. 2090

Fuel: MX 30%

Restrictor: None

Glow Plug: O.S. P3

Notes:

Differential:

	Front	Center	Rear
Fluid:	12.5k (Mixed)	#5447 FT 15k	#5454 FT 7k
Gears:	HTC	HTC	HTC
Mass:	N/A	N/A	N/A
O-Rings:	No	No	No

Shocks:

	Front	Rear
Piston:	#81200 6 x 1.3 Kit	3 x 1.3 + 3 x 1.4 Kit Tapered
Fluid:	#5423 FT 40 wt	#5423 FT 40 wt
Bladder:	#81453 Stiff	#81453 Stiff
Rebound:	0	0
Spring:	#81225 V2 Blue	#81231 V2 Blue
Length:	109 mm	130 mm

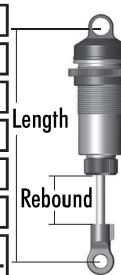

Track Info:

Size: Small Medium Large Extra Large
Surface: Dirt Carpet Astroturf Multi Surface
Traction: Low Medium High Very High
Moisture: Dry Damp Wet
Condition: Indoor Outdoor Dusty Hard Packed

 Bumpy Grooved Smooth Loamy
Temperature: Ambient: 85°F Track: N/A

Notes:

Vehicle Comments:

Notes: #81116 FT Engine Mount Base; #81117 FT Engine Mounts; #81465 FT Gear Mesh Inserts; #81493 FT HD Gearboxes

Tires:

Front Tire/Compound/Insert/Wheel:

JConcepts Reflex / Blue / Dirt Tech / Mono

Rear Tire/Compound/Insert/Wheel:

JConcepts Reflex / Blue / Dirt Tech / Mono

Notes: Foam Glued To The Wheel

Radio Tray Flex Assembly:

Transponder Mount: **None:**
Radio Tray Brace:

Body and Wing:

Body: JConcepts Prototype

Wing: JConcepts F21

Wing Height: High: Low:
Gap to Tower: 19 mm

Weight:

Total Weight: N/A

Notes: