

Front Suspension:

RESET

Ride Height: 39 mm

Camber: N/A

Toe: Tierod Gap = 61.5 mm

Anti-Roll Bar

Size: 2.3 mm (Black)

Gap: 2 mm

Ackerman

Notes: #81063 FT Steering Block Arm +2 Deg, Aluminum

Drive Shaft: CVAs: Universals:

Chassis Brace: Short: Long:

Hex: T-Works 9 mm

Notes: #81417 FT Graphite Arm Stiffeners, front upper
#81085 FT Servo Saver Arm, Aluminum

Upper Ball Type: #81067 Steel

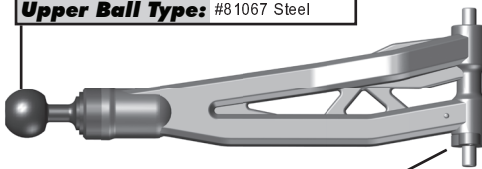

Wheelbase Shim: 0 mm R / 1 mm F

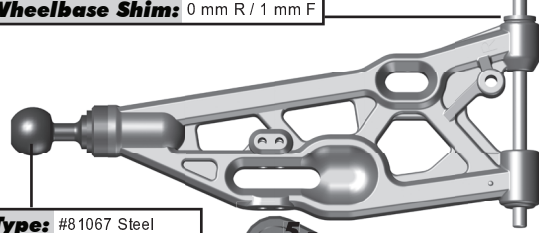

Caster Shim: 2 mm F / 0 mm R

Lower Ball Type: #81067 Steel

Upper Ball Shim: 0.70 mm

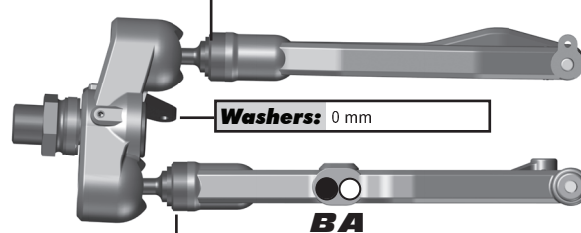

Washers: 0 mm

BA

Lower Ball Shim: 0 mm

Upper Arm Mount:



Arm Mount A:



Arm Mount B:

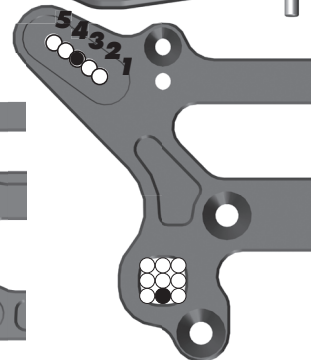

Rear Suspension:

Ride Height: 42 mm

Camber: -1 Tierod Gap = 56.6 mm

Anti-Roll Bar

Size: 2.7 mm (Blue)

Gap: 0, Ball Reversed

Drive Shaft: CVAs: Universals:

Chassis Brace: Short: Long:

Hex: T-Works 9 mm

Notes: #81077 FT Aluminum Rear Hubs

Hub Shim: 2.5 mm F / 2.5 mm R

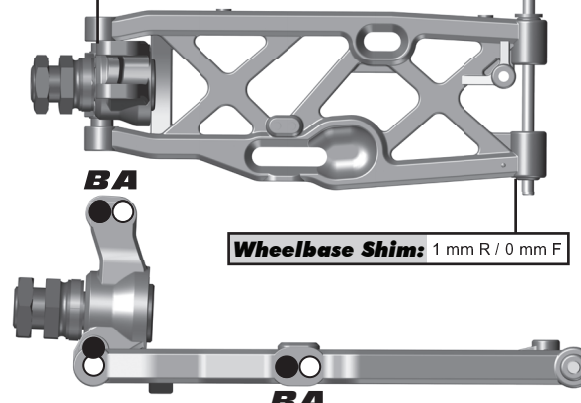

BA

Wheelbase Shim: 1 mm R / 0 mm F

BA

Arm Mount C:



Arm Mount D:

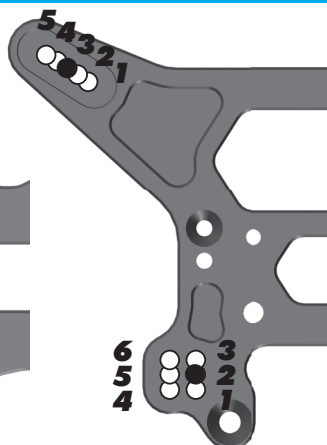

Electronics and Engine:

Radio: Sanwa

Receiver Battery: LRP 2500 mAh

Throttle Servo: Sanwa PGS-XA

Steering Servo: Sanwa PGS-XR

EPA: Throttle: N/A % Brake: N/A %

Brake Bias: 40%F / 60% R **D/R:** 100 %

Engine: LRP ZZ.21c Ongaro **Temp:** N/A

Muffler: O.S. 2090 **Fuel:** RunnerTime 25%

Restrictor: 6.5mm **Glow Plug:** P3

Differential:

| | Fluid | Gear Set | Planet O-Rings |
|----------------|-----------|----------|----------------|
| Front: | 15,000 AE | HTC | None |
| Center: | 15,000 AE | HTC | None |
| Rear: | 10,000 AE | HTC | None |

Clutch and Gearing:

Spur Gear: 46 **Bell:** 13

Shoes: 3 x Aluminum

Springs: 3 x 1.0

Shocks:

| | Front | Rear |
|---------------------|-----------------------------------------------------------------------------------------------------|------------------------------|
| Piston: | #81210 8x1.2 Tapered, Angled | #81211 8x1.3 Tapered, Angled |
| Fluid: | 32.5 wt | 35 wt |
| Cap: | Fastrace | Fastrace |
| Rebound: | 0 mm | 0 mm |
| Spring: | #81225 V2 Blue | #81231 V2 Blue |
| Free Length: | 109 mm | 127 mm |
| Notes: | #81407 Shock Seal Bushing Set; #81164 & #81165 Fox Shock Bodies; #81176 & #81177 FT Chrome Shock | |

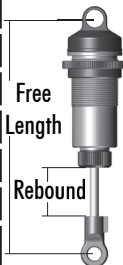

Track Info:

Size: Small Medium Large Extra Large

Surface: Dirt Carpet AstroTurf Multi Surface

Traction: Low Medium High Very High

Moisture: Dry Damp Wet

Condition: Indoor Outdoor Dusty Hard Packed
Bumpy Grooved Smooth Loamy

Temperature: Ambient: 45F Track: 45F

Notes:

Tires:

Front Tires: AKA Grid Iron

Front Compound: Super Soft

Front Insert: AKA

Rear Tires: AKA Grid Iron

Rear Compound: Super Soft

Rear Insert: AKA

Wheel (F/R): AKA

Notes:

Body, Wings:

Body: JConcepts Finisher

Wing: HB

Wing Height: High: Low:

Gap to Tower:

Weight:

Total Vehicle Weight: N/A

Notes:

Vehicle Comments:

Notes: #81115 Motor Mount; #81382 FT Aluminum Cross Pins; #1367 FT 20mm Servo Horn;