

Front Suspension

Anti Roll Bar:

- 2.2mm Black
- 2.5mm Silver
- 2.8mm Gold
- 3.0mm Black

Steering System:

- Swing Rack
 - Bellcrank Rack
- back mid front

Bumpsteer Washers:

2 mm In / 2 mm Out

Camber: 0

Caster: 16

Toe: 0

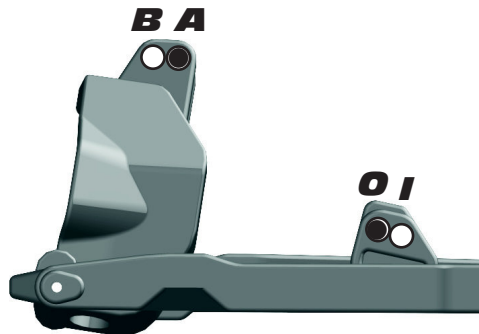

Ride Height: 39 mm

Upper Hinge Pin Bushing

Front # 2
Up Down

Rear # 2
Up Down

B-Plate Type

Low Original

Kickup Bushing A-Plate

1
Up Down

Rear Suspension

RESET

Anti Roll Bar:

- 2.2mm Black
- 2.5mm Silver
- 2.8mm Gold
- 3.0mm Black

Wheelbase:

- Long
- Medium
- Short

Camber: -2

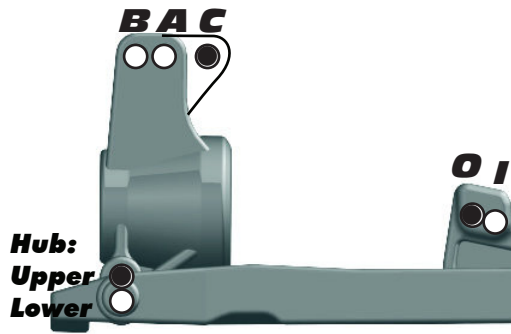

Hub:
Upper
Lower

Ride Height: 44 mm

Toe Bushing D-Plate

1
In Out

Squat Bushing C-Plate

2
Up Down

Front Shocks

Spring: Silver **Shock Cap:** Bladder
Shock Fluid: 35 wt **Length:** 112.5 mm
Piston: 6x1.3 Tapered **Rebound:** 3 mm

Rear Shocks

Spring: Kyo Truggy Lt Blue **Shock Cap:** Bladder
Shock Fluid: 35 wt **Length:** 125 mm
Piston: 6x1.3 Tapered **Rebound:** 3 mm

Chassis Braces

- Chassis Braces:
- Pivot
- Molded
- Aluminum

Wheel Hex

- Wheel Hex:
- Narrow
- Wide

Caster Blocks

- Caster Blocks:
- Vertical
- Inclined

Chassis Weight

Weight: 4050g

Rear Hubs

- Rear Hubs:
- Standard
- CNC FT Alum.

Differentials

Front Diff: 7,000
 Center Diff: 10,000
 Rear Diff: 7,000
 Notes:

Body / Wing

Body Type: JConcepts Punisher
Wing Type: JConcepts Punisher
 High Rotation Side Dams
Gap to Tower (MM): 27 mm

Gearing / Clutch

Spur Gear: 50
Clutch Bell: 14
Clutch Shoes: 3 x Hard Aluminum
Clutch Spring: 2 x 1.1 + 1 x 1.0

Engine

Engine: LRP .21ZZ CC
Restrictor: **Temp:** 240
Muffler: Novarossi 9901
Glow Plug: LRP WT3 **Fuel:** Strike V2

Tires

Tire (F/R): JConcepts Hybrids / JConcepts Hybrids
Compound (F/R): Blue / Blue
Inserts (F/R): Closed Cell / Closed Cell
Wheel (F/R): JConcepts Elevated / JConcepts Elevated
 Notes:

Radio / Servos

Radio: Futaba 4PKS **Brake Bias:** 50/50
Throttle / Steering Servo: Futaba S9353HV / Futaba S9353HV
Throttle / Brake expo: -10% / 0%
Steering expo: 0%
Dual Rate: 100%

Race and Vehicle Comments

Qualify: 7 **Main:** A **Finish:** 11 **TQ:** _____
Comments: High wing mount; Carbon shock towers;

Track Info

- Traction:** High Medium Low
- Surface:** Smooth Bumpy Blue Groove
- Soft Dirt Grass Clay Wet
- Astroturf Dusty Other: _____