

**Front Suspension**

**Anti Roll Bar:**

- 2.2mm Black
- 2.5mm Silver
- 2.8mm Gold
- 3.0mm Black

**Steering System:**

- Swing Rack
  - Bellcrank Rack
- back  
mid  
front

**Bumpsteer**

**Washers:** 1.5mm

**Camber:** -1.5 degrees

**Caster:** 16 degrees

**Toe:** 0

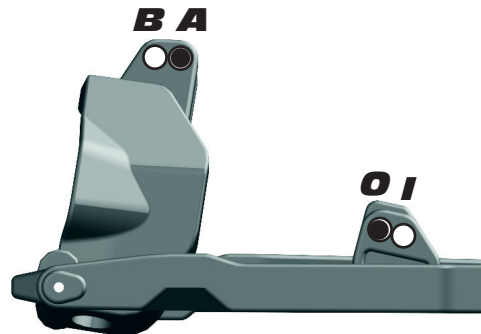

**Ride Height:** 39 mm

**Upper Hinge Pin Bushing**

Front # 2 Dot  
Up  Down

Rear # 2 Dot  
Up  Down

**B-Plate Type**

Low  Original

**Kickup Bushing A-Plate**

# 1 Dot  
Up  Down

**Rear Suspension**

RESET

**Anti Roll Bar:**

- 2.2mm Black
- 2.5mm Silver
- 2.8mm Gold
- 3.0mm Black

**Wheelbase:**

- Long
- Medium
- Short

**Camber:** -1.5 degrees

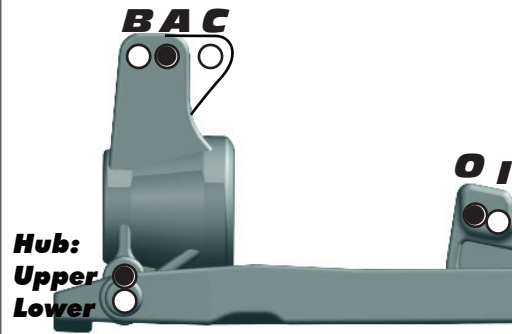

**Ride Height:** 43 mm

**Toe Bushing D-Plate**

# 1 Dot  
In  Out

**Squat Bushing C-Plate**

# 1 Dot  
Up  Down

**Front Shocks**

**Spring:** Silver **Shock Cap:** Bladder  
**Shock Fluid:** 42.5 wt **Length:** 113 mm  
**Piston:** 4x1.6 Drilled **Rebound:** 0

**Rear Shocks**

**Spring:** Silver **Shock Cap:** Bladder  
**Shock Fluid:** 40 wt **Length:** 125mm  
**Piston:** 4x1.6 Drilled **Rebound:** 0

**Chassis Braces**

- Chassis Braces:
- Pivot
- Molded
- Aluminum

**Wheel Hex**

- Wheel Hex:
- Narrow
- Wide

**Caster Blocks**

- Caster Blocks:
- Vertical
- Inclined

**Chassis Weight**

Weight: \_\_\_\_\_

**Rear Hubs**

- Rear Hubs:
- Standard
- CNC FT Alum.

**Differentials**

Front Diff: 10,000  
 Center Diff: 10,000  
 Rear Diff: 7,000  
 Notes: \_\_\_\_\_

**Body / Wing**

**Body Type:** Jconcepts Punisher  
**Wing Type:** Jconcepts Punisher  
 High Rotation Side Dams  
**Gap to Tower (MM):** 28mm

**Gearing / Clutch**

**Spur Gear:** 50  
**Clutch Bell:** 14  
**Clutch Shoes:** Hard Aluminum  
**Clutch Spring:** 2x1.1, 1x1.0

**Engine**

**Engine:** LRP ZZ.21C  
**Restrictor:** 7mm **Temp:** 250  
**Muffler:** Reedy 2035  
**Glow Plug:** LRP WT4 **Fuel:** Sidewinder 30%

**Tires**

**Tire (F/R):** Jconcepts Hybrids / Jconcepts Hybrids  
**Compound (F/R):** Blue / Blue  
**Inserts (F/R):** JConcepts Closed Cell / JConcepts Closes Cell  
**Wheel (F/R):** JConcepts Elevated / JConcepts Elevated  
 Notes: \_\_\_\_\_

**Radio / Servos**

**Radio:** Futaba 4pks-R **Brake Bias:** 50/50  
**Throttle / Steering Servo:** Futaba BLS157HV / Futaba BLS157HV  
**Throttle / Brake expo:** 0 / 0  
**Steering expo:** 0  
**Dual Rate:** 100%

**Race and Vehicle Comments**

**Qualify:** \_\_\_\_\_ **Main:** \_\_\_\_\_ **Finish:** \_\_\_\_\_ **TQ:** \_\_\_\_\_  
**Comments:** 2.4 front roll bar; High wing mount;

**Track Info**

- Traction:** High  Medium  Low
- Surface:** Smooth  Bumpy  Blue Groove
- Soft Dirt  Grass  Clay  Wet
- Astroturf  Dusty  Other: \_\_\_\_\_