

Front Suspension

Anti Roll Bar:

- 2.2mm Black
- 2.5mm Silver
- 2.8mm Gold
- 3.0mm Black

Steering System:

- Swing Rack
 - Bellcrank Rack
- back
mid
front

Bumpsteer

Washers: 2 mm (Mugen Rod Ends)

Camber: -2°

Caster: 16°

Toe: 0°

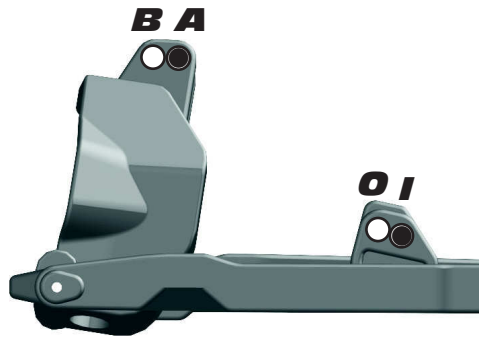

Ride Height: 39 mm

Upper Hinge Pin Bushing

Front # 1 Dot
Up Down

Rear # 1 Dot
Up Down

B-Plate Type

Low Original

Kickup Bushing A-Plate

1 Dot
Up Down

Rear Suspension

RESET

Anti Roll Bar:

- 2.2mm Black
- 2.5mm Silver
- 2.8mm Gold
- 3.0mm Black

Wheelbase:

- Long
- Medium
- Short

Camber: -2°

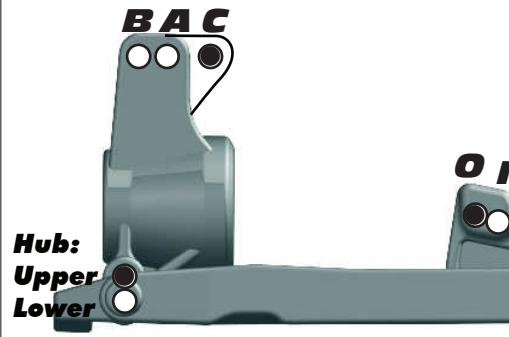

Hub:
Upper
Lower

Ride Height: 45 mm

Toe Bushing D-Plate

1.5 Dot
In Out

Squat Bushing C-Plate

1
Up Down

Front Shocks

Spring: Associated Silver **Shock Cap:** HB Cap

Shock Fluid: Associated 37.5 wt **Length:** 109 mm

Piston: 6 x 1.3 GHEA Tapered **Rebound:** 2 mm

Rear Shocks

Spring: Associated Silver **Shock Cap:** HB Cap

Shock Fluid: Associated 35 wt **Length:** 125 mm

Piston: 6 x 1.3 GHEA Tapered **Rebound:** 2 mm

Chassis Braces

- Chassis Braces:**
- Pivot**
- Molded**
- Aluminum**

Wheel Hex

- Wheel Hex:**
- Narrow**
- Wide**

Caster Blocks

- Caster Blocks:**
- Vertical**
- Inclined**

Chassis Weight

Weight: _____
At minimum total weight

Rear Hubs

- Rear Hubs:**
- Standard**
- CNC FT Alum.**

Differentials

Front Diff: 10,000

Center Diff: 10,000

Rear Diff: 7,000

Notes: _____

Body / Wing

Body Type: JConcepts Punisher

Wing Type: UpGrade Vortex

Gap to Tower (MM): 28 mm

Gearing / Clutch

Spur Gear: 50

Clutch Bell: 14

Clutch Shoes: 3 x Hard Aluminum

Clutch Spring: 3 x 1.1

Engine

Engine: Orion 5 Port

Restrictor: 7.5 mm **Temp:** _____

Muffler: Orion 2013

Glow Plug: Orion 5 **Fuel:** Sidewinder 30%

Tires

Tire (F/R): AKA Impact / AKA Impact

Compound (F/R): Soft / Soft

Inserts (F/R): AKA / AKA

Wheel (F/R): AKA / AKA

Notes: _____

Radio / Servos

Radio: Airtronics M12 **Brake Bias:** 50 / 50

Throttle / Steering Servo: Airtronics 9480 / Futaba

Throttle / Brake expo: 0% / 0%

Steering expo: 0%

Dual Rate: 100%

Race and Vehicle Comments

Qualify: 7 **Main:** A **Finish:** 3 **TQ:** _____

Comments: Carbon shock towers; Front sway bar tips bent in 30°; RC8T shocks

Track Info

- Traction:** High Medium Low
- Surface:** Smooth Bumpy Blue Groove
- Soft Dirt** Grass Clay Wet
- Astroturf** Dusty Other: Rough