

Driver: Davide Ongaro

Event: Testing

Date: Spring 2022

Track: Ongaroring

Qualify: N/A

TC: Main: N/A

Finish: N/A

Best Lap Time: N/A

Front Suspension:

RESET

Ride Height: 23 mm

Toe: 0.5° Toe Out Hex: #81081 FT +0

Anti-Roll Bar

Size: 2.2 mm

Gap: 0.3 mm

Ackerman

Steering Arm Plate: #81063 +2 Deg

Drive Shaft: CVAs: Universals:

Notes:

Caster Shim: 0 mm R / 4 mm F

Insert Type: #81533 Winged Plastic

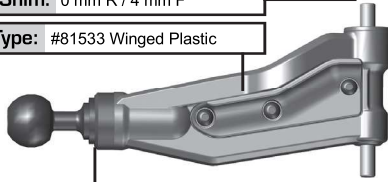

Upper Ball Type: #81068 FT Aluminum

Upper Ball Shim: 2.0 mm

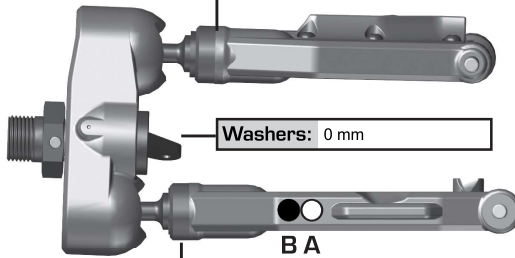

Washers: 0 mm

Lower Ball Shim: 0 mm

Wheelbase Shim: 0 mm R / 1 mm F

Lower Ball Type: #81067 Steel

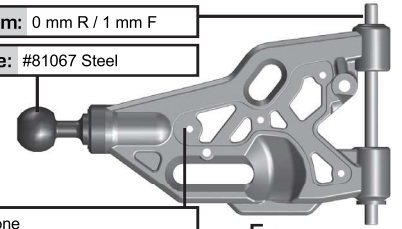

Insert Type: None

Insert Location: Top: Bottom:

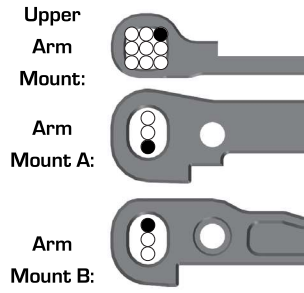

Rear Suspension:

Ride Height: 29 mm

Camber: -1° Hex: #81081 FT +0

Anti-Roll Bar

Size: 2.9 mm

Gap: 0.3 mm (Ball Reversed)

Drive Shaft: CVAs: Universals:

Chassis Brace:

Ball:

Inserts:

Notes:

Hub Shim: Forward (0 mm F / 5 mm R)

Wheelbase Shim: 0 mm F / 1 mm R

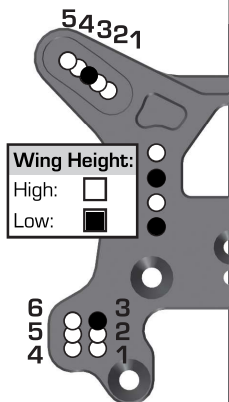
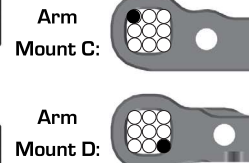
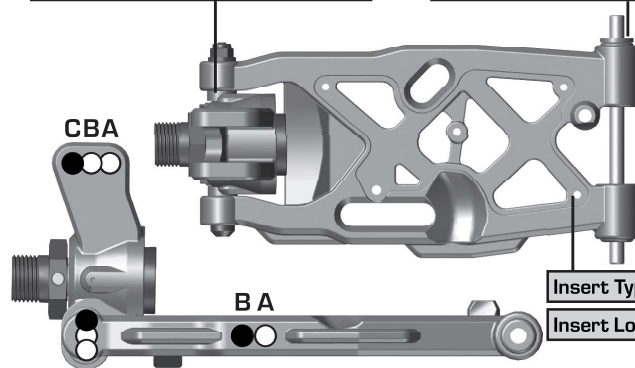

Electronics:

Radio: Sanwa Exses ZZ Servo: Sanwa PGS-XB

EPA: Throttle: 100 % Brake: 84 %

EXPO: Throttle: 0 % Brake: 0 %

ESC: Hobbywing Xr8 Pro Motor: Hobbywing 2200

Battery: #27382 Reedy SG5 6400 mAh Shorty Saddle Brick

Battery Position: Rear Center Forward

Battery Tray Position: Rear Forward

Notes:

Differential:

	Front	Center	Rear
Fluid:	#5454 FT 7k	#5456 FT 20k	#5444 FT 4k
Gears:	HTC	HTC	HTC
Mass:			
Notes:	Fill fluid to kit setting		

Gearing:

Spur Gear: 46 Pinion: #89597 FT 15T

Notes:

Shocks:

	Front	Rear
Piston:	#81210 8x1.2 FT Tapered / Angled	#81211 8x1.3 FT Tapered / Angled
Fluid:	#5434 FT 42.5 wt	#5478 FT 45 wt
Bladder:	#81453 Hard	#81453 Hard
Rebound:	None	None
Spring:	Mugen 9.0T	Mugen 10.5T
Length:	104.0 mm	124.0 mm
Notes:		



Track Info:

Size: Small Medium Large Extra Large

Surface: Dirt Carpet AstroTurf Multi Surface

Traction: Low Medium High Very High

Moisture: Dry Damp Wet

Condition: Indoor Outdoor Dusty Hard Packed

Bumpy Grooved Smooth Loamy

Temperature: Ambient: Track:

Notes:

Tires:

Front Tire/Compound/Insert/Wheel:

AKA Impact / Super Soft Long Wear / AKA Closed Cell / AKA

Rear Tire/Compound/Insert/Wheel:

AKA Impact / Super Soft Long Wear / AKA Closed Cell / AKA

Notes:

Radio Tray Flex Assembly:

Transponder Mount: None:

Radio Tray Brace:

Body and Wing:

Body: #81583 RC8B4e Gamma

Nose Cone: Standard

Rear Wing: #81554 Team Associated RC8B4

Angle: 0° 2° 4° Button: Flat Fin

Vent Holes: 5 mm Across Whole Lip

Weight:

Total Weight:

Notes:

Vehicle Comments:

Notes: