

## Front Suspension:

**Ride Height:** 24 mm (Body On + Full Tank)

**Toe:** Tierod Gap = 25.4 mm    **Hex:** #81081 +0

**Anti-Roll Bar**

**Size:** 2.1 mm

**Gap:** 2.0 mm



**Ackerman**

1 2 3

**Steering Arm Plate:** #81066 +0 Deg

**Drive Shaft:** CVAs:  Universals:

**Notes:** Servo Mount Disconnected From Rest Of Tray

**Caster Shim:** 0.9 mm

**Insert Type:** None

**Upper Ball Type:** #81068 FT Aluminum

**Upper Ball Shim:** 0.35 mm

**Washers:** 0 mm

**Lower Ball Shim:** 0 mm

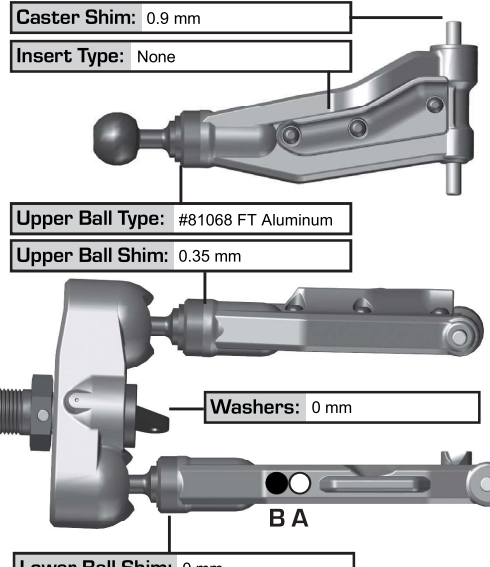

**Wheelbase Shim:** 1 mm R / 0 mm F

**Lower Ball Type:** #81068 FT Aluminum

**Insert Type:** None

**Insert Location:** Top:  Bottom:

**Upper Arm Mount:**

**Arm Mount A:**

**Arm Mount B:**

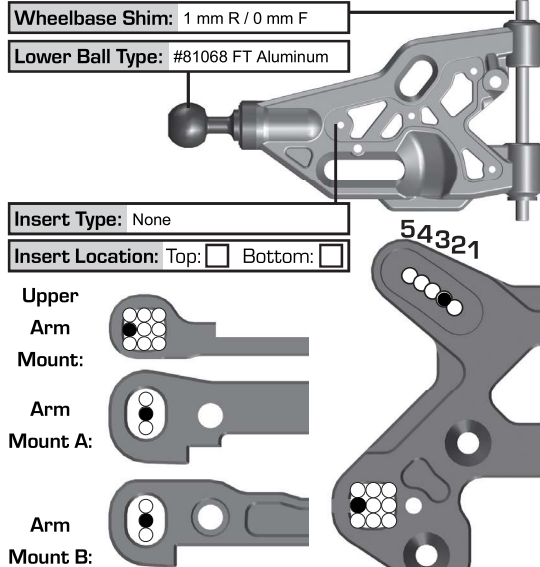

## Rear Suspension:

**Ride Height:** 26 mm (Body On + Full Tank)

**Camber:** -2°    **Hex:** #81079 +1

**Anti-Roll Bar**

**Size:** 2.5 mm

**Gap:** Ball Reversed & Flush

**Drive Shaft:** CVAs:  Universals:

**Chassis Brace**

**Pivot Type:** Kit Insert

**Insert Type:** Kit Insert

**Notes:** #81489 FT V2 Rear Hubs, Aluminum

**Hub Shim:** Middle (2.5 mm F / 2.5 mm R)

**Wheelbase Shim:** 0 mm F / 1 mm R

**Arm Mount C:**

**Arm Mount D:**

**Insert Type:** None

**Insert Location:** Top:  Bottom:

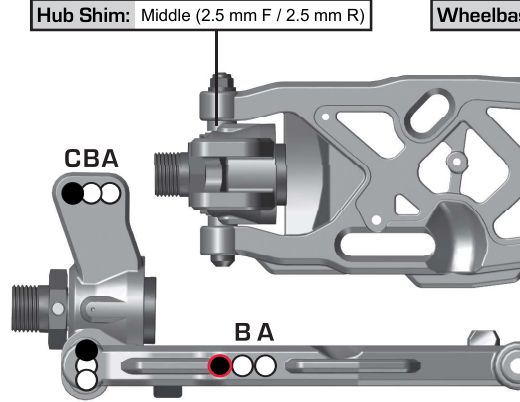

**Wing Height:** High:  Low:

6 5 4

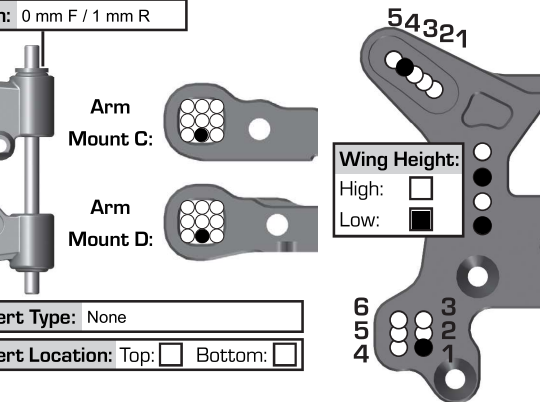

## Electronics and Engine:

**Radio:** Futaba T10PX

**Receiver Battery:** #27313 Reedy 2400 7.4v

**Throttle Servo:** #27153 Reedy RT5012A HV (Speed 95%)

**Steering Servo:** #27153 Reedy RT5012A HV (Expo -15%, Speed 88%)

**EPA:** Throttle: 51 %    Brake: 80 %

**Brake Bias:** 50F / 50R    **D/R:** 86 %

**Engine:** Reds Superevoce 721 Gen3    **Temp:** N/A

**Pipe:** Reds 2143 X-1 Torque    **Fuel:** VP Powermaster Pro Race 30%

**Restrictor:** Reds 7.0 mm    **Glow Plug:** Reds TS3

**Notes:** Throttle Gap = 6.4mm; Kyosho Air Boot

## Differential:

|               | Front                               | Center       | Rear         |
|---------------|-------------------------------------|--------------|--------------|
| <b>Fluid:</b> | #5455 FT 10k                        | #5454 FT 7k  | #5455 FT 10k |
| <b>Gears:</b> | LTC                                 | HTC          | LTC          |
| <b>Mass:</b>  | 2.5 g Refill                        | 2.0 g Refill | 2.0 g Refill |
| <b>Notes:</b> | #81012 Differential Outdrive, 17 mm |              |              |

## Clutch and Gearing:

**Spur Gear:** 46    **Bell:** 13

**Shoes:** 2 x #81377 Hard Composite + 2 x #81375 Hard Aluminum

**Springs:** 2 x #81366 0.95 Green + 2 x #81367 1.00 Gold

**Notes:** #81370 RC8B3.1 Flywheel, Aluminum; #81009 42/12 Ring/Pinion

## Shocks:

|                 | Front  | Rear                               |
|-----------------|--|------------------------------------|
| <b>Piston:</b>  | #81201 3 x 1.35 + 3 x 1.45 Flat                | #81206 3 x 1.45 + 3 x 1.50 Tapered |
| <b>Fluid:</b>   | #5473 FT 32.5 wt                               | #5471 FT 27.5 wt                   |
| <b>Bladder:</b> | #81184 Bleeder (Emulsion)                      | #81184 Bleeder (Emulsion)          |
| <b>Rebound:</b> | 0 mm   | 0 mm                               |
| <b>Spring:</b>  | #81224 V2 Gray                                 | #81233 V2 Pink                     |
| <b>Length:</b>  | 105.5 mm                                       | 128.5 mm                           |
| <b>Notes:</b>   | #81621 +2 Front & +2 Rear Shock Eyelet         |                                    |
|                 | #81171 3.5 x 39.5mm FT TiN Shock Shafts, Front |                                    |
|                 | #81611 3.5 x 44 mm TiN Shock Shafts, Rear      |                                    |



## Track Info:

**Size:** Small  Medium  Large  Extra Large

**Surface:** Dirt  Carpet  AstroTurf  Multi Surface

**Traction:** Low  Medium  High  Very High

**Moisture:** Dry  Damp  Wet

**Condition:** Indoor  Outdoor  Dusty  Hard Packed   
Bumpy  Grooved  Smooth  Loamy

**Temperature:** Ambient: 42°F    Track: N/A

**Notes:**

## Tires:

**Front Tire/Compound/Insert/Wheel:** JConcepts Reflex / Green / JConcepts Dirt Tech / JConcepts Mono

**Rear Tire/Compound/Insert/Wheel:** JConcepts Reflex / Green / JConcepts Dirt Tech / JConcepts Mono

**Notes:** V-Cut Foam

**Radio Tray Flex Assembly:**

**Transponder Mount:**  None:

**Radio Tray Brace:**

## Body and Wing:

**Body:** #81568 Team Associated RC8B4, Mu

**Nose Cone:** Team Associated Standard

**Rear Wing:** JConcepts Razor

**Angle:** 0°  2°  4°  **Button:** Flat  Fin

**Vent Holes:** 6 x 13 mm

**Weight:**

**Total Weight:** N/A

**Notes:**

## Vehicle Comments:

**Notes:** #81589 FT RC8B4 RWB Chassis; #27035 Reedy Electronic Power Switch