

RC B TEAM **B4.2e** KIT

1:8 Scale 4WD Electric Off Road
Competition Buggy Kit



TEAM ASSOCIATED



1:8 Scale 4WD Electric Off Road Competition Buggy Kit Manual

#80955 RC10B4.2e Team Kit



CHAMPIONS *by* DESIGN

AssociatedElectrics.com

TEAM ASSOCIATED

:: Introduction

Thank you for purchasing this Team Associated product. This assembly manual contains instructions and tips for building and maintaining your new Kit. Please take a moment to read through this manual to help familiarize yourself with these steps. We are continually changing and improving our designs; therefore, actual parts may appear slightly different than in the illustrations. New parts will be noted on supplementary sheets located in the appropriate parts bags. Check each bag for these sheets before you start to build.

:: KIT Features

Features in the RC8B4.2e Kit:

- New molded height-adjustable gearboxes front and rear
- New offset hubs and updated rear suspension arms to accommodate new hub geometry
- New high-volume center differential
- New high-downforce wing
- Now includes FT hard-anodized aluminum shock bushings
- RWB/FWB adjustable weight bias chassis
- Soft blend material suspension arms
- 8-degree KPI steering blocks included
- 44/13 ring and pinion gear sets
- 92mm universal driveshafts with 17mm outdrives
- Both 19mm and 20mm diameter HTC internal differential gear sets included
- 47T machined steel spur gear included
- Centralized drivetrain and chassis configuration optimized for shorty-style batteries
- Adjustable battery tray design with hook and loop strap for retaining batteries
- Includes both stiff shock bladders and emulsion seals

:: Additional

Your new RC8B4.2e Kit comes as a kit. There are items you will need to complete your kit (refer to the website for suggestions):

- | | | |
|---|---------------------------|-------------------------|
| • 2 or 3 channel radio/transmitter (2.4GHz recommended) | • Transmitter batteries | • Steering servo |
| • Two 2s or One 4s LiPo Battery Pack | • 1/8th scale sized motor | • 1/8th scale sized ESC |
| • Polycarbonate-specific paint | • Thread-locking compound | • Needle-nose pliers |
| • 1:8 scale buggy tires and wheels | • CA (cyanoacrylic) glue | • Hobby knife |
| • Reamer / hole punch | • Ride height gauge | |

:: Other Helpful Items

- | | |
|--|---|
| • Silicone Shock/Diff Fluids (Refer to the website for complete listings): | • Body Scissors (AE #1737) |
| • Shock Pliers | • FT Hex Wrenches / Nut Drivers - (#1519) |
| • Reamer / Hole Punch - (#1499) | • Calipers or a Precision Ruler |
| • Ride Height Gauge | • Wheel Nut Wrench 17mm - (#1571) |
| • FT Hex Wrenches - (#1506, 1518) | |
| • Wire Cutters | |
| • Turnbuckle Wrench - (#1114) | |















Associated Electrics, Inc.
21062 Bake Parkway
Lake Forest, CA 92630

















Customer Service
Tel: 949.544.7500
Fax: 949.544.7501

:: Hardware - 1:1 Scale View







Flat Head (fhcs)

	2.5x6mm (4675)
	2.5x8mm (31448)
	3x5mm (31540)
	3x6mm (31541)
	3x8mm (25201)
	3x10mm (25202)
	3x12mm (25203)
	3x14mm (89208)
	3x30mm (89212)
	4x10mm (81262)
	4x12mm (89214)
	4x14mm (89217)
	4x16mm (81263)
	4x20mm (81264)







Button Head (bhcs)

	2.5x6mm (31520)
	2.5x8mm (31521)
	2.5x18mm (81259)
	3x6mm (31531)
	3x8mm (31532)
	3x10mm (25211)
	3x12mm (89202)
	3x14mm (25187)
	3x16mm (89203)
	3x18mm (2308)
	3x20mm (25188)
	3x22mm (25189)
	3x24mm (89204)
	4x14mm (81260)
	4x16mm (81261)





Set Screws

	3x3mm (25225)
	3x6mm (81257)
	3x10mm (4671)
	3x12mm (81258)
	4x4mm (7732)
	5x4mm (89221)







Socket Head (shcs)

	2x5mm (31511)
	2x16mm (7184)
	3x10mm (25620)
	3x12mm (89454)
	3x24mm (89225)
	3x26mm (89226)
	3x28mm (89227)







LP Socket Head (lp shcs)

	3x6mm (41089)
	3x10mm (41090)
	3x14mm (41094)
	3x16mm (41093)
	3x20mm (41091)

Ball Bearings

	5x8x2.5mm (8680)
	5x10x4mm (91560)
	6x10mm (31404)
	6x12x4mm (91561)
	8x16x5mm (91564)
	8x16x5mm flanged (91565)

Nuts (lock/plain)

	M3 Nut (91477)
	M3 Alum. Locknut, Blue (31550)
	M3 Locknut, Black (25215)
	M3 Locknut w/Flange (25612)
	FT 3mm Locknuts, Blue(25392)
	FT M4 Locknut, Blue (31551)
	M4 Locknut, Serrated (91738)

:: Table of Contents

1..... Cover	16 - 18.....Rear End Build (Bags 7.1, 7.2, 7.3)
2..... Introduction	19.....Rear Hubs Build (Bags 8.1, 8.2)
3..... 1:1 Hardware "Fold Out"	20 - 21.....Center Bulkhead Build (Bag 9.1)
4..... Table of Contents	21 - 22.....Radio Tray Build (Bag 10.1, 11.1)
5 - 7.....Differentials Build (Bags 1.1, 1.2)	22 - 23.....Battery Tray Build (Bag 12.1)
7 - 8.....Shocks Build (Bag 2.1)	24.....Wheels / Tires / Body (Misc.)
9.....Turnbuckles Build (Bags 3.1)	25.....Droop Settings
10 - 11.....Steering / Chassis Build (Bag 4.1)	26.....Back Cover
11 - 14.....Front Gearbox Build (Bags 5.1, 5.2, 5.3)	
14 - 15.....Steering Blocks Build (Bags 6.1)	

:: Notes



This symbol indicates a special note or instruction in the manual.



This symbol indicates a specific build order in the manual.



This symbol indicates a Racers Tip.



There is a 1:1 hardware foldout page in the front of the manual. To check the size of a part, line up your hardware with the correct drawing until you find the exact size. Each part in the foldout has a number assigned to it for ordering replacement parts.

Associated Electrics, Inc.
21062 Bake Parkway
Lake Forest, CA 92630



Customer Service
Tel: 949.544.7500
Fax: 949.544.7501

:: Differential Build (Front and Rear) - Bag 1.1, 1.2 - Step 1

#6588 black grease

81697 Outdrive O-Ring 5.8x1.9mm

81379 Diff Case

91564 8x16x5 Bearing

81381 Diff Shim 6x8x0.20mm

#6588 black grease

81012 17mm Outdrive

81681 Pin 2.5x12mm

81681 Diff Sun Gear, 19mm HTC

Note: Both 81681 19mm HTC and 81380 20mm HTC Sun Gears included. **DO NOT MIX!**

All 19mm HTC gears (81681) are kit setup.

Align pin with groove in sun gear

:: Differential Build (Front and Rear) - Bag 1.1, 1.2 - Step 2

81681 x2 Diff Crosspin

81681 x4 Diff Planet Gears, 19mm and 20mm HTC

81681 x4 Diff Shim 3.6x12x0.12mm

#6588 black grease

81468 Diff Ring Gear, 44/13 Set

81697 Outdrive O-Ring 5.8x1.9mm

91564 8x16x5 Bearing

81381 Diff Shim 6x8x0.20mm

#6588 black grease

81012 17mm Outdrive

:: Differential Build (Front and Rear) - Bag 1.1, 1.2 - Step 3

81681 Pin 2.5x12mm

81681 Diff Sun Gear, 19mm HTC

81384 Diff Gasket

#6588 black grease

Align pin with groove in sun gear

Racer's Tip:
Use black grease (#6588) to coat the back side of the diff gasket [i.e. not the entire gasket] before installation!

:: Differential Build (Front and Rear) - Bag 1.1, 1.2 - Step 4



Racer's Tip:

Fill diff above the cross pins, below the planet gears as shown.

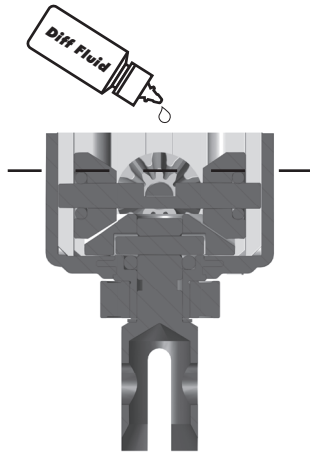

25202 X4
M3x10mm
FHCS

Front Diff Fluid:
15,000cst #5447

Rear Diff Fluid:
5,000cst #5453

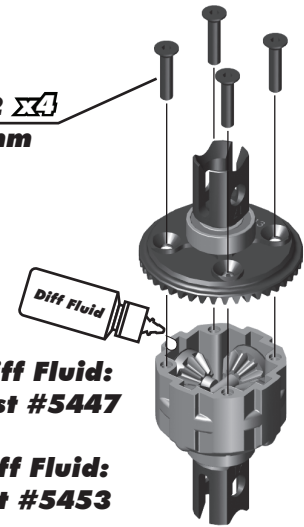

:: Differential Build (Center) - Bag 1.1, 1.2 - Step 5

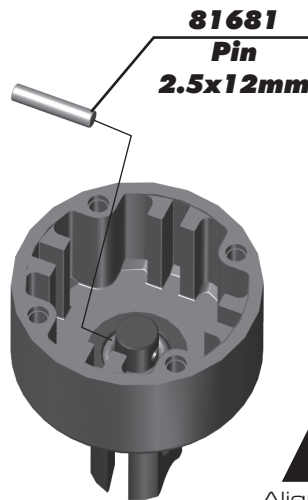
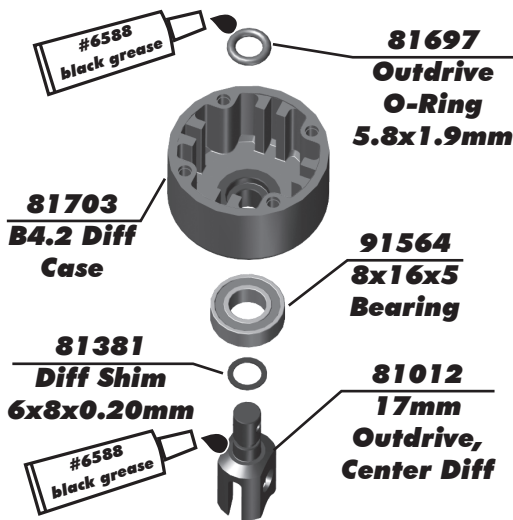

Align pin with groove in sun gear

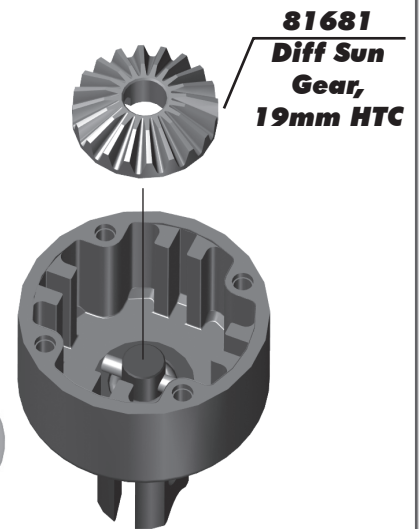

:: Differential Build (Center) - Bag 1.1, 1.2 - Step 6

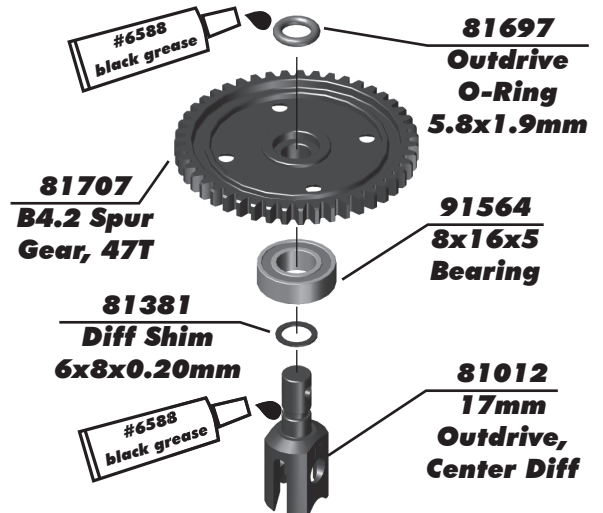
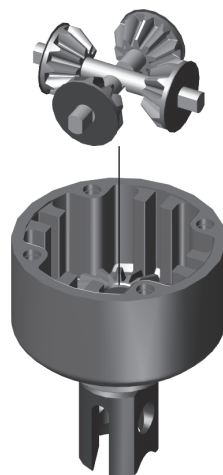
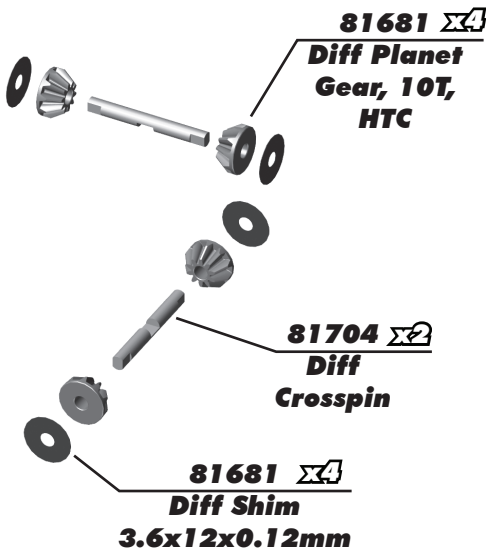

:: Differential Build (Center) - Bag 1.1, 1.2 - Step 7

81681 Pin 2.5x12mm

81681 Diff Sun Gear, 19mm HTC

81705 B4.2 Center Diff Gasket, 0.5mm

#6588 black grease

Racer's Tip:
Use black grease (#6588) to coat the back side of the diff gasket (i.e. not the entire gasket) before installation!

Align pin with groove in sun gear

:: Differential Build (Center) - Bag 1.1, 1.2 - Step 8

Racer's Tip:
Fill diff above the cross pins, below the planet gears as shown.

Diff Fluid

25202 x4 M3x10mm FHCS

Center Diff Fluid: 10,000cst #5455

:: Shocks Build - Bag 2.1 - Step 1

81202 FT Shock Piston (6x1.3 flat) Front

89215 2.5mm Shock Piston Locknut

89278 2.6x6mm Washer

81172 TiN Shock Shaft, 3.5x33.5mm (Front)

81173 TiN Shock Shaft, 3.5x42.5mm (Rear)

81162 Shock Body, 26.5mm (Front)

81163 Shock Body, 36.5mm (Rear)

81185 Shock Body O-Ring

81185 O-Ring Hat Bushing

81188 Shock Body Seal Retainer

81186 Shock O-Ring

81185 O-Ring Spacer

:: Shocks Build - Bag 2.1 - Step 2

Racer's Tip:
Use green slime (#1105) to lube the o-rings before installation!

81190 Shock Boots

81562 Rod End Ball

81452 RC8B3.2 Shock Cap

81621 Shock Rod End
Front: +2
Rear: +2

81512 Shock Cap Insert

91492 2x4mm BHCS

91492 Gasket (2)

81184 Emulsion Seal (1)

Option Included: 81453 16mm Stiff Bladder

! When installing the emulsion seal, make sure it is correctly seated within the shock cap as shown.

:: Shocks Build - Bag 2.1 - Step 3

! Fill to top of shock body.

Front Shock Fluid: 40wt #5423

Rear Shock Fluid: 35wt #5429

! Tighten to snug, may be a small gap when sealed.

! Bleed Procedure:
Remove bleeder screw
Tilt shock so bleed hole is the highest point and slowly compress the shaft.

Stop about 3mm from full compressed, install the screw, and check that the shock is not pressurized.
If so, bleed out a small amount more.

:: Shocks Build - Bag 2.1 - Step 4

! The springs come with a colored marking pre-installed for easy identification

81221 Spring Collar O-Ring, 20mm

81221 Spring Collar, 20mm

81658 Front Spring, White (5.05lb/in) L68, 7.75T, 1.5D

81663 Rear Spring, Green (3.60lb/in) L83, 10.00T, 1.5D

81512 Spring Cup

25211 3x10mm BHCS

1

2

:: Turnbuckles Build - Bag 3.1 - Step 1

Steering Servo Turnbuckle

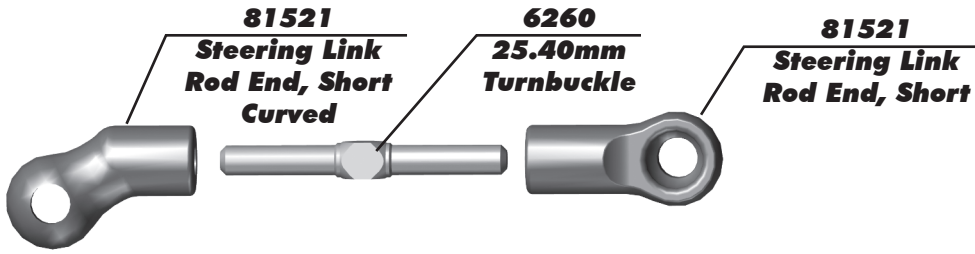

11.50mm (0.45")

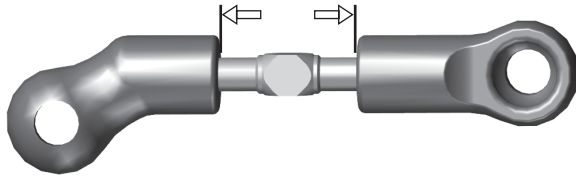

Set aside until page 22

:: Turnbuckles Build - Bag 3.1 - Step 2

Steering Turnbuckle

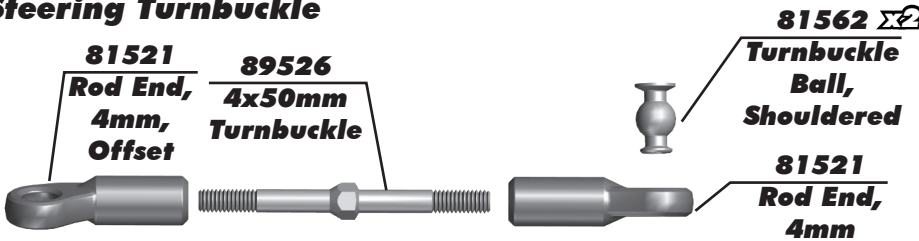

24.20mm (0.952")

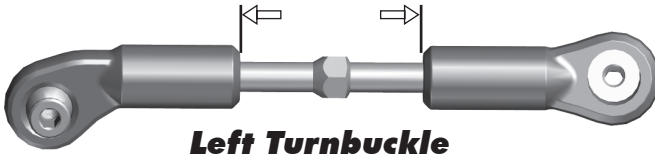

Left Turnbuckle

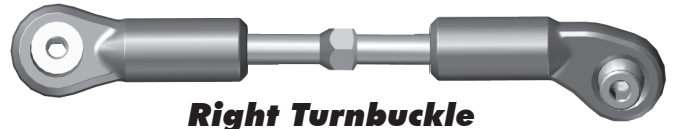

Right Turnbuckle



Note the direction of turnbuckle ball



Set aside until page 15

:: Turnbuckles Build - Bag 3.1 - Step 3

Rear Hub Turnbuckle

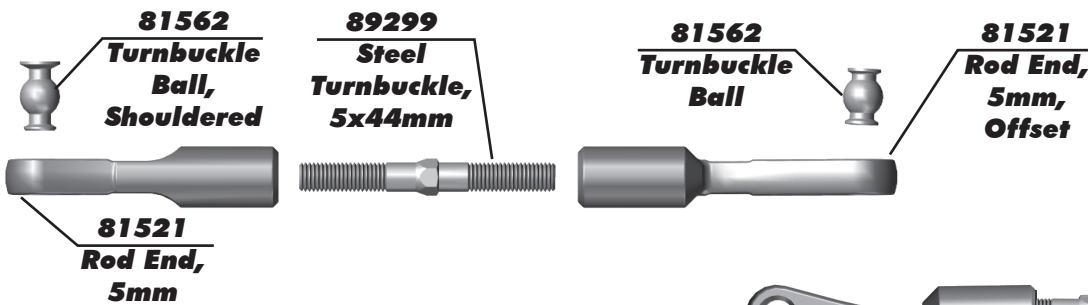

13.70mm (0.539")

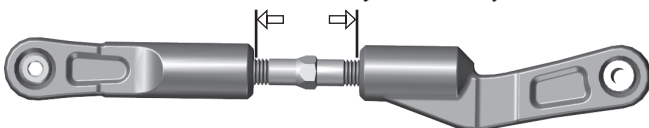

Left Turnbuckle

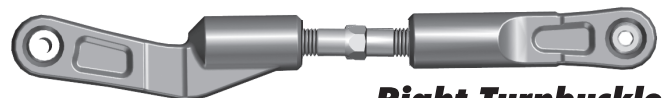

Right Turnbuckle



Set aside until page 19

:: Steering / Chassis Build - Bag 4.1 - Step 1

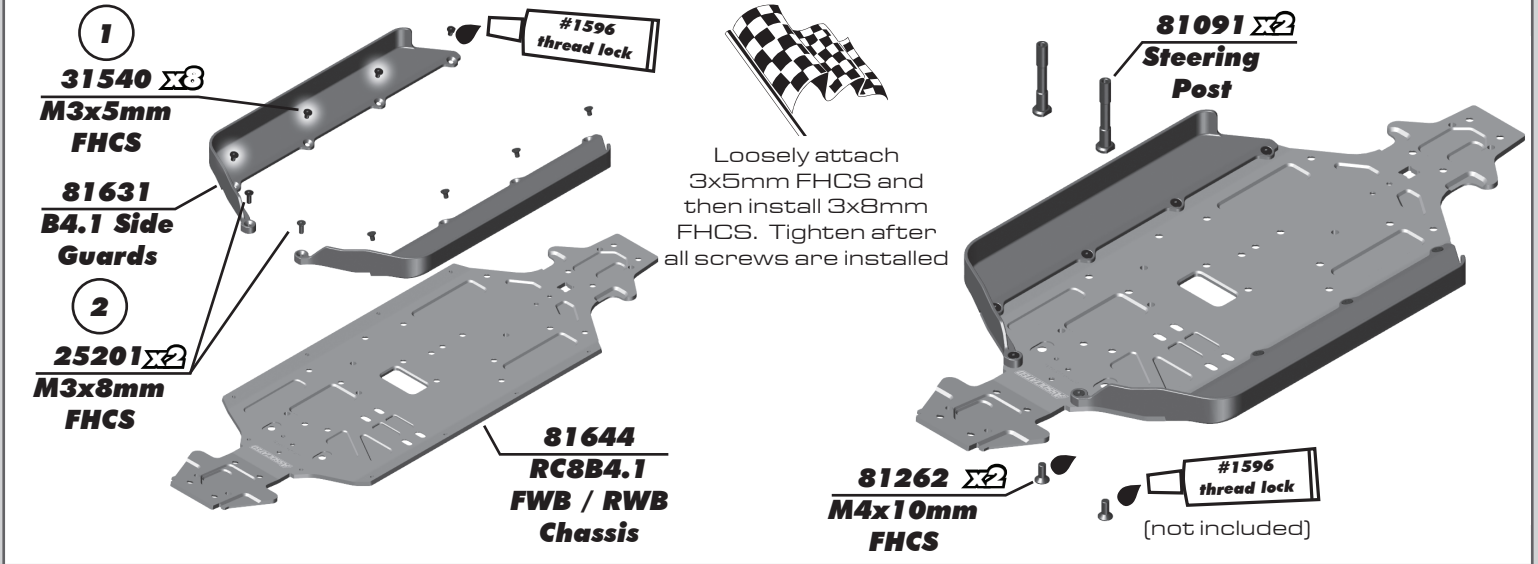

:: Steering / Chassis Build - Bag 4.1 - Step 2

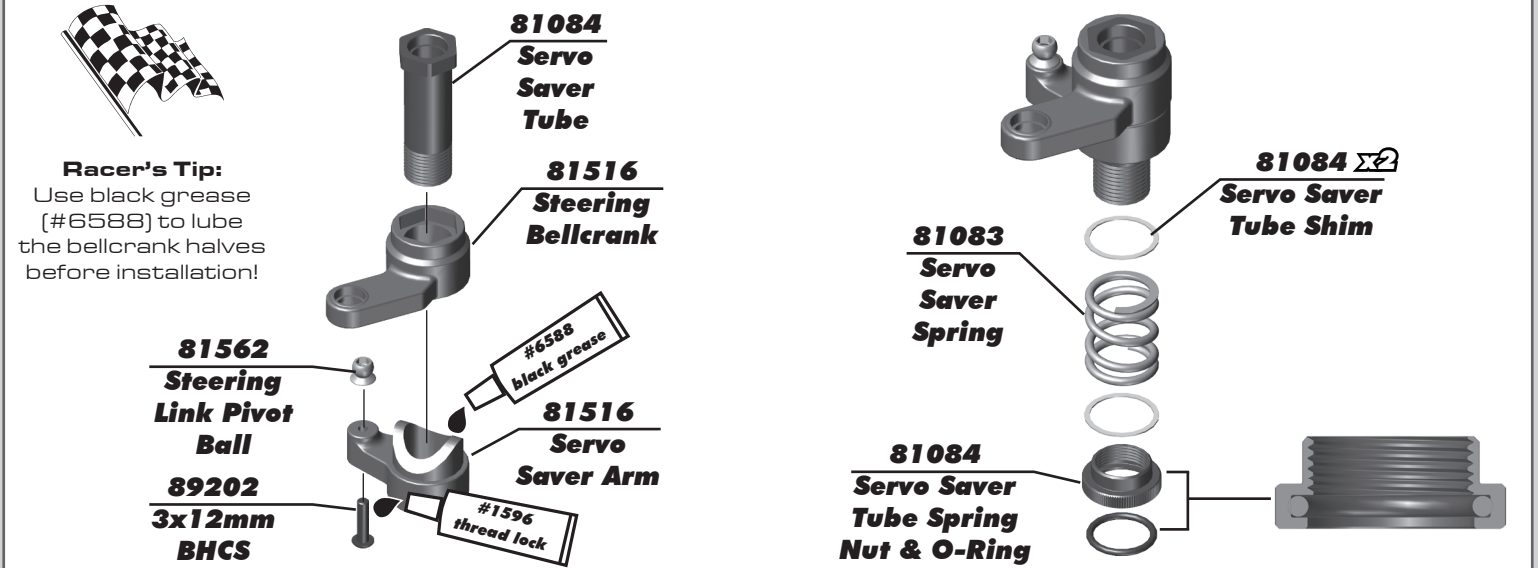

:: Steering / Chassis Build - Bag 4.1 - Step 3

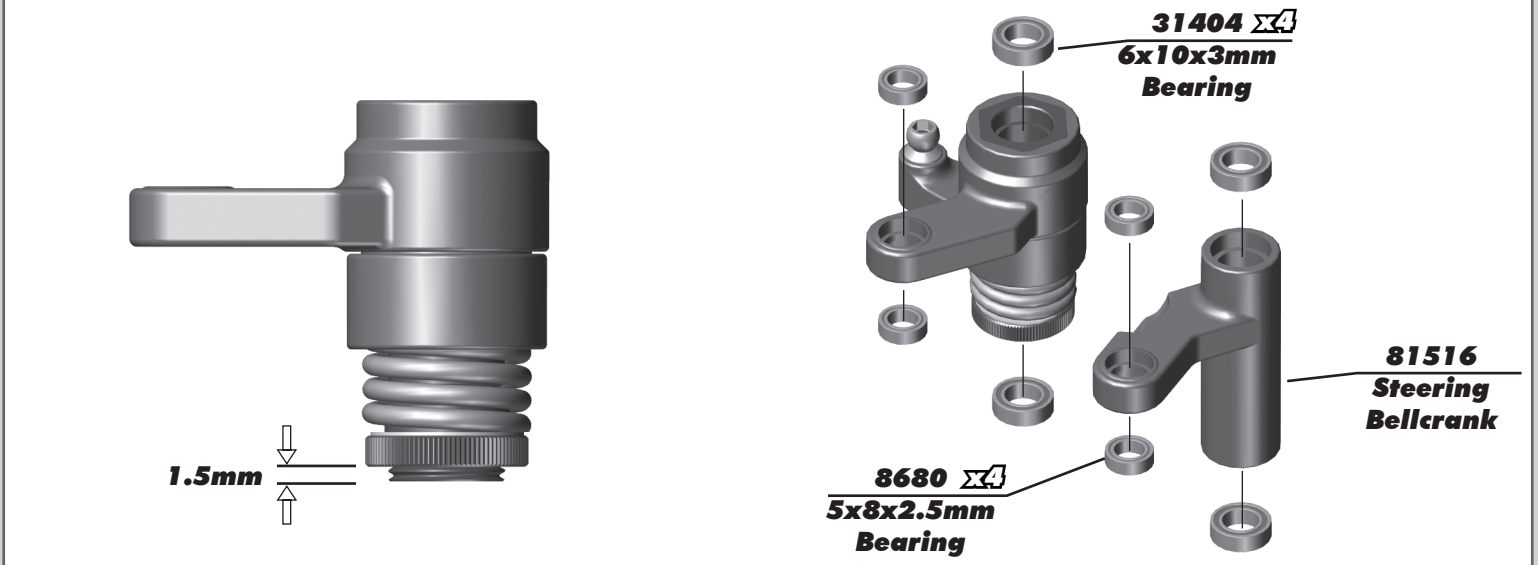

:: Steering / Chassis Build - Bag 4.1 - Step 4

25201 *x2*
3x8mm FHCS

#1596
thread lock

81518
Steering Rack

81517 *x2*
Steering Bellcrank Nut

! 3mm hex wrench fits bellcrank nut hex.

:: Front Gearbox Build - Bag 5.1, 5.2, 5.3 - Step 1

Pinion Height Insert:
Dot at bottom = 0
No dot = +1
Dot at top = +2

81689
B4.2 Pinion Height Insert, Team Kit +1

4675 *x2*
M2.5x6mm FHCS

91561 *x2*
6x12x4mm Bearing

#6588
black grease

81468
Diff Pinion Gear, 44/13 set

81687
Dust Cap

4675
2.5x6mm FHCS

81687
B4.2 Gearbox, (Inboard)

81687 *x2*
B4.2 Gearbox Flange Insert, Middle

#1596
thread lock

89221
5x4mm Set Screw

81564
Dogbone Outdrive, Front

Racer's Tip:
Clearance here for easier diff installation.

Racer's Tip:
De-grease and clean set screw and cup for best thread lock.

:: Front Gearbox Build - Bag 5.1, 5.2, 5.3 - Step 2

81689 *x2*
B4.2 Gearbox Diff Height Insert, Team Kit 0

81381
Diff Shim 13.5x15.8x0.20mm

!
STEP 1

81687 *x2*
Anti-Roll Bar Cap

25620 *x2*
M3x10mm SHCS

#6588
black grease

81687
B4.2 Gearbox, (Outboard)

!
STEP 2

Step 1:
Add shims on the ring gear side to TIGHTEN gear mesh. Subtract shims on this side to LOOSEN gear mesh.
NOTE:
Start 1x Thick 0.2mm

Step 2:
Add or subtract shims here to finalize diff side to side play once gear mesh is set from Step 1.
Recommended diff "side-to-side" clearance (gearbox assembly) 0.10 - 0.25mm. Start with 1 x 0.1mm.

Note:
0.1 mm shim can be used for fine tuning of gear mesh

:: Front Gearbox Build - Bag 5.1, 5.2, 5.3 - Step 3

**Kit Setup:
Arm Mount B**

**Kit Setup:
Arm Mount A**

**Drop Screw:
Kit Setup:
1.5mm**

Build left and right side!

Start here, adjust to 101 mm shock length.

81520

Arm Mount Insert, Down

81566

Arm Mount A

81446

Suspension Arm Shim

81567

Arm Mount B

81260

M4x14mm BHCS

81260

M4x14mm BHCS

81520

Arm Mount Insert, Center

81641

B4.1 Hinge Pin, 66.3mm

89317

Drop Screw

81636

Front Lower Arm, Soft

:: Front Gearbox Build - Bag 5.1, 5.2, 5.3 - Step 4

81512

Anti-Roll Bar Link

81585

Anti-Roll Bar Pivot

81585

Rod End Ball

89203

M3x16mm BHCS

Note direction

:: Front Gearbox Build - Bag 5.1, 5.2, 5.3 - Step 5

Center the anti-roll bar collet on the anti-roll bar; then tighten the 3x3mm set screw.

Note direction

81129

(Front) Anti-Roll Bar, 2.2mm

Center!

81585

Anti-Roll Bar Collet

25225

3x3mm Set Screw

Front anti-roll bar gap: 2.0mm

:: Front Gearbox Build - Bag 5.1, 5.2, 5.3 - Step 6



Tighten 3x6mm set screws just enough to still allow the anti-roll bar to move freely.

31521 $\Sigma 2$
M2.5x8mm BHCS

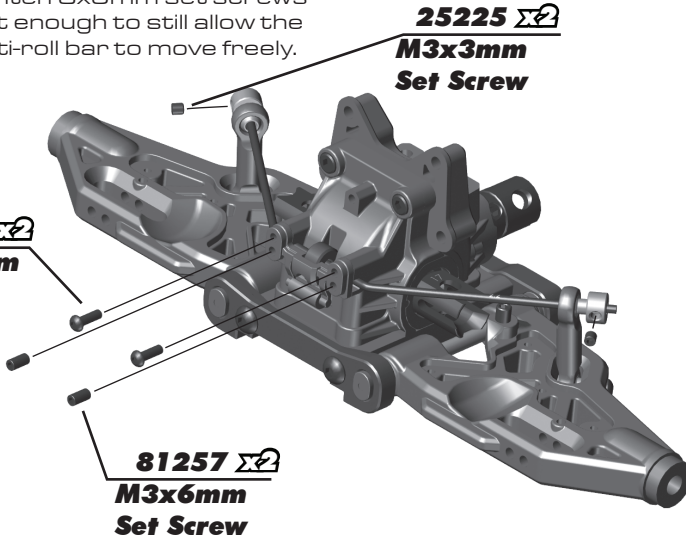

25225 $\Sigma 2$
M3x3mm Set Screw

81257 $\Sigma 2$
M3x6mm Set Screw

89214
4x12mm FHCS

89216
M4 Locknut

81524
Body Post, Front

81576
RC8B4e Top Plate

31532
3x8mm BHCS

81525
Chassis Brace, Front

:: Front Gearbox Build - Bag 5.1, 5.2, 5.3 - Step 7

Kit Setup:



81647
B4.1 Upper Link Mount, Angled

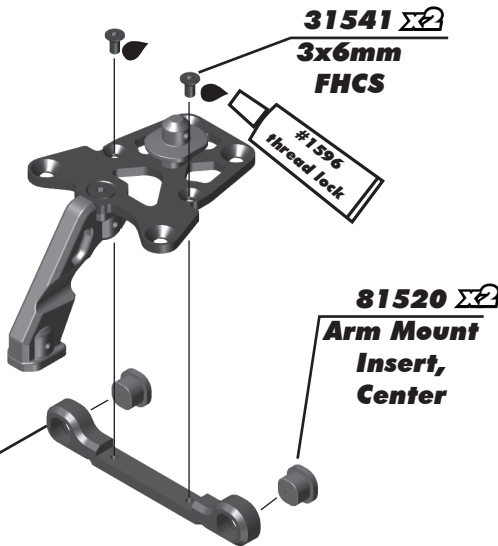

31541 $\Sigma 2$
3x6mm FHCS

81520 $\Sigma 2$
Arm Mount Insert, Center

89214 $\Sigma 2$
4X12mm FHCS

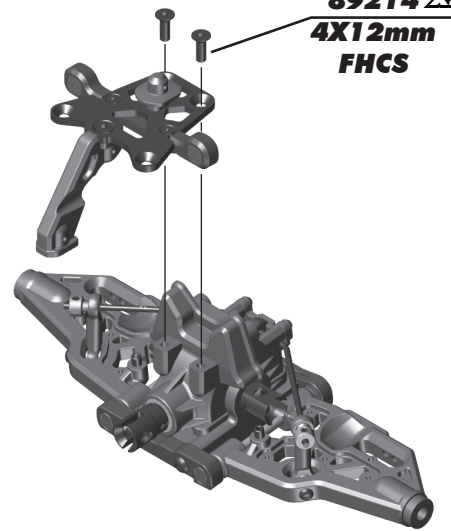

:: Front Gearbox Build - Bag 5.1, 5.2, 5.3 - Step 8

Kit Setup:



81591 $\Sigma 2$
FT Shock Bushing, 14mm

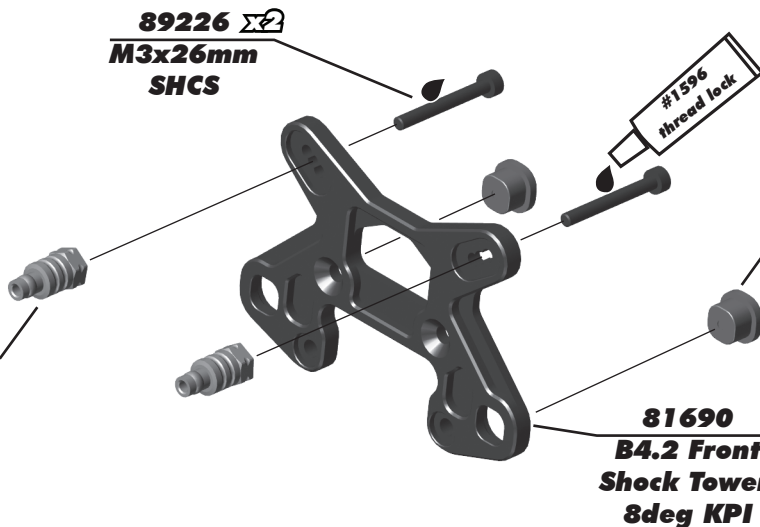

89226 $\Sigma 2$
M3x26mm SHCS

81690
B4.2 Front Shock Tower, 8deg KPI



Install arm mount inserts in direction shown!

81520 $\Sigma 2$
Arm Mount Insert, Side

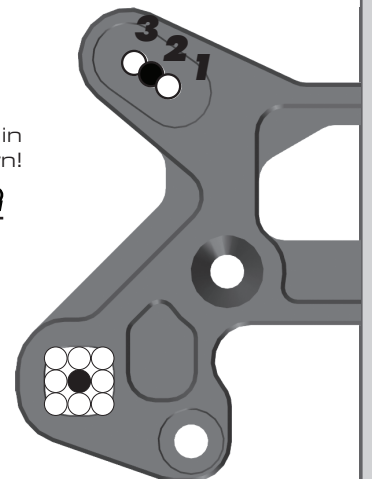

:: Front Gearbox Build - Bag 5.1, 5.2, 5.3 - Step 9

Build left and right side!

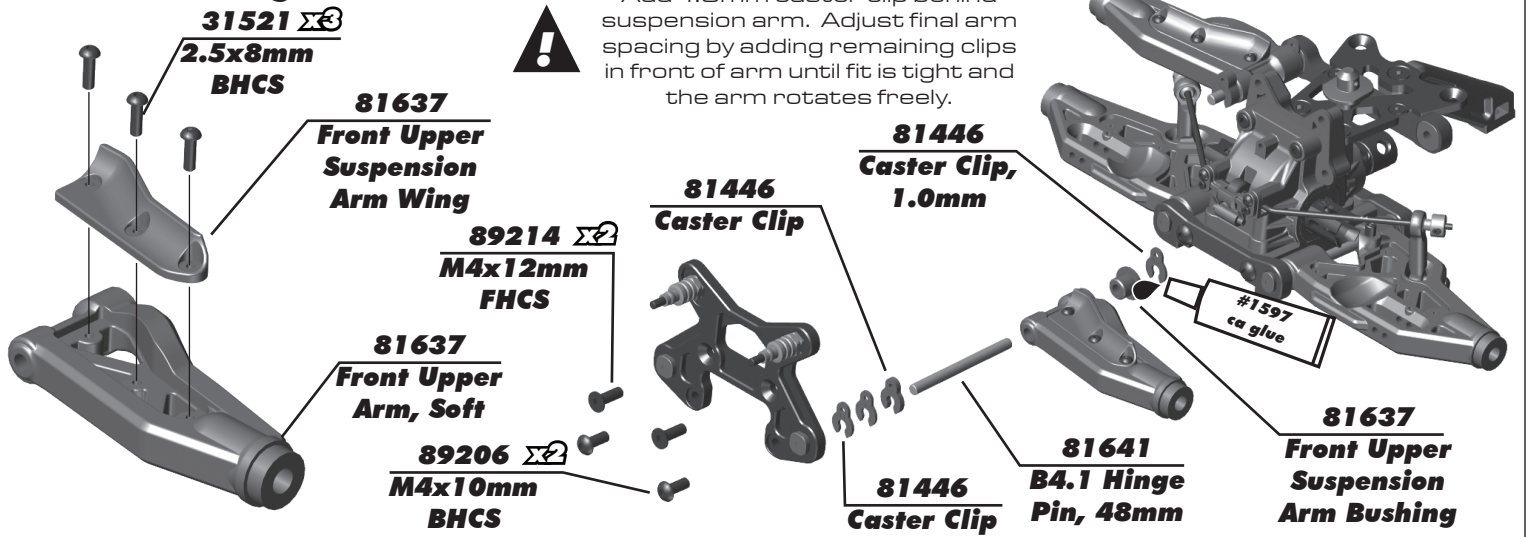

:: Steering Blocks Build - Bag 6.1 - Step 1

Build left and right side!

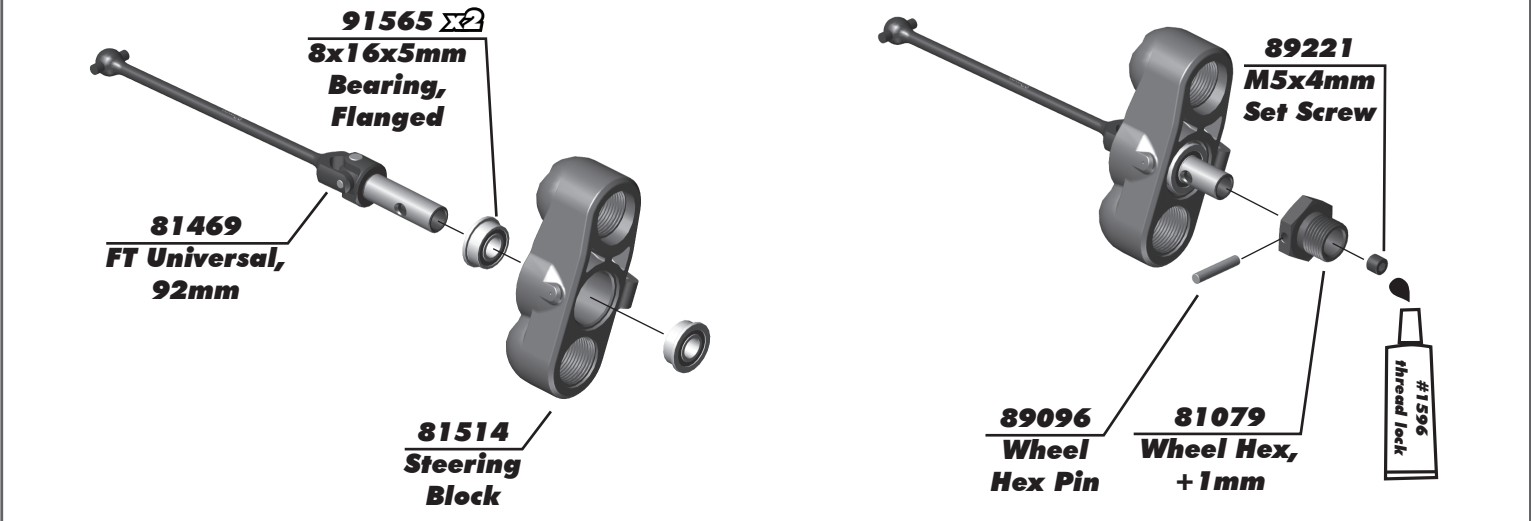

:: Steering Blocks Build - Bag 6.1 - Step 2

Build left and right side!

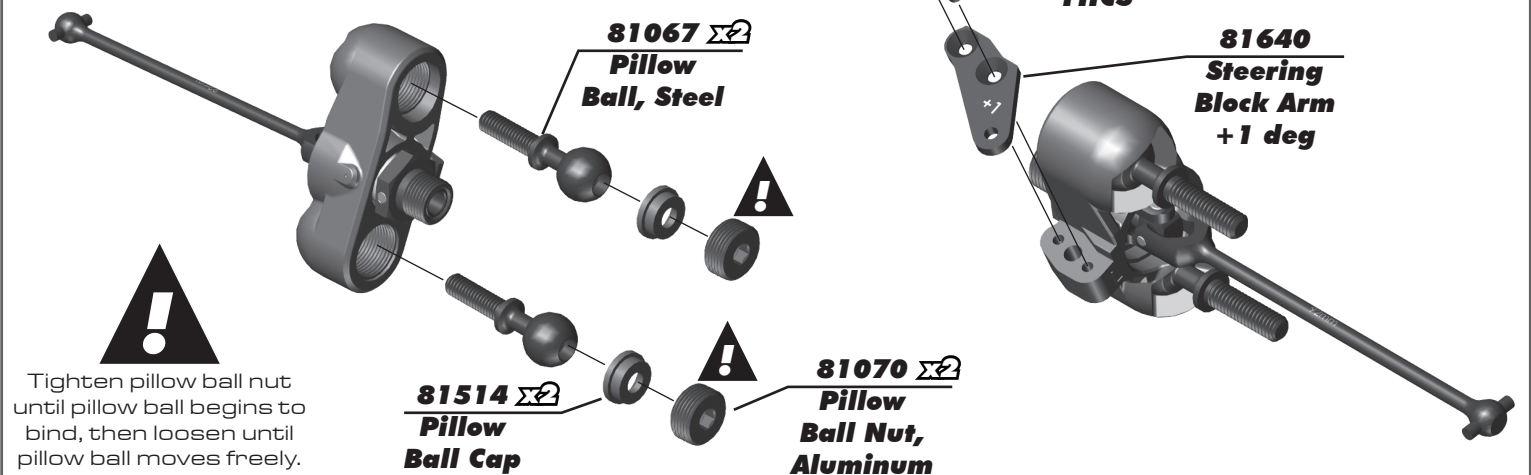

:: Steering Blocks Build - Bag 6.1 - Step 3

81056 $\Sigma 2$
Suspension Arm Endcap

81072
Pillow Ball Shim (1.4mm)

81072
Pillow Ball Shim (0.7mm)

31385
Bulkhead Washer, 7.8x3.0x1mm Blue Aluminum

25620
M3x10mm SHCS

#1596
Thread Lock

Pillow Ball Shims

0.35mm 0.7mm 1.4mm

:: Steering Blocks Build - Bag 6.1 - Step 4

81262 $\Sigma 2$
M4x10mm FHCS

#1596
thread lock

31532 $\Sigma 2$
M3x8mm BHCS

81643
B4.1 Front Bumper

31386 $\Sigma 2$
Bulkhead Washer, 7.8x3.0x2mm Blue Aluminum

89216
M4 Locknut

89214
M4x12mm FHCS

81264 $\Sigma 2$
M4x20mm FHCS

89217 $\Sigma 2$
M4x14mm FHCS

Kit Setup:

1 2 3 TOP 1 2 3

For attaching steering link to steering rack

:: Steering Blocks Build - Bag 6.1 - Step 5

Kit Setup:
Mount the front shock in the outside hole on the front arm.

A B

25612
M3 Locknut W/ Flange

81509
Shock Pin

81257
M3x6mm Set Screw

:: Rear End Build - Bag 7.1, 7.2, 7.3 - Step 1

Pinion Height Insert:
 Dot at bottom = 0
 No dot = +1
 Dot at top = +2

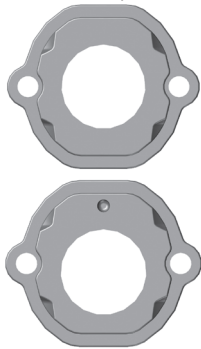

81689
B4.2 Pinion Height Insert, Team Kit 0

Racer's Tip:
 Clearance here for easier diff installation.

4675 $\Sigma 2$
M2.5x6mm FHCS

#6588
black grease

81468
Diff Pinion Gear, 44/13 set

81688
Dust Cap

4675
M2.5x6mm FHCS

81688
B4.2 Gearbox, (Inboard)

81688 $\Sigma 2$
B4.2 Gearbox Flange Insert, Low

#1596
thread lock

89221
M5x4mm Set Screw

91561 $\Sigma 2$
6x12x4mm Bearing

81565
Dogbone Outdrive, Rear

Racer's Tip:
 De-grease and clean set screw and cup for best thread lock.

:: Rear End Build - Bag 7.1, 7.2, 7.3 - Step 2

81689 $\Sigma 2$
B4.2 Gearbox Diff Height Insert, Team Kit 0

81381
Diff Shim 13.5x15.8x0.20mm

25620 $\Sigma 2$
M3x10mm SHCS

81688
Anti-Roll Bar Cap

81688
B4.2 Gearbox, (Outboard)

#6588
black grease

STEP 1

STEP 2

Step 1:
 Add shims on the ring gear side to TIGHTEN gear mesh. Subtract shims on this side to LOOSEN gear mesh.
 NOTE:
 Start 1x Thick 0.2mm

Step 2:
 Add or subtract shims here to finalize diff side to side play once gear mesh is set from Step 1. Recommended diff "side-to-side" clearance (gearbox assembly) 0.10 - 0.25mm. Start with 1 x 0.1mm.

Note:
 0.1mm shim can be used for fine tuning of gear mesh

:: Rear End Build - Bag 7.1, 7.2, 7.3 - Step 3

Kit Setup:



81454
Arm Mount, HRC, Narrow (C)

81260 $\Sigma 2$
M4x14mm BHCS

81520 $\Sigma 2$
Arm Mount Insert, Center

:: Rear End Build - Bag 7.1, 7.2, 7.3 - Step 4

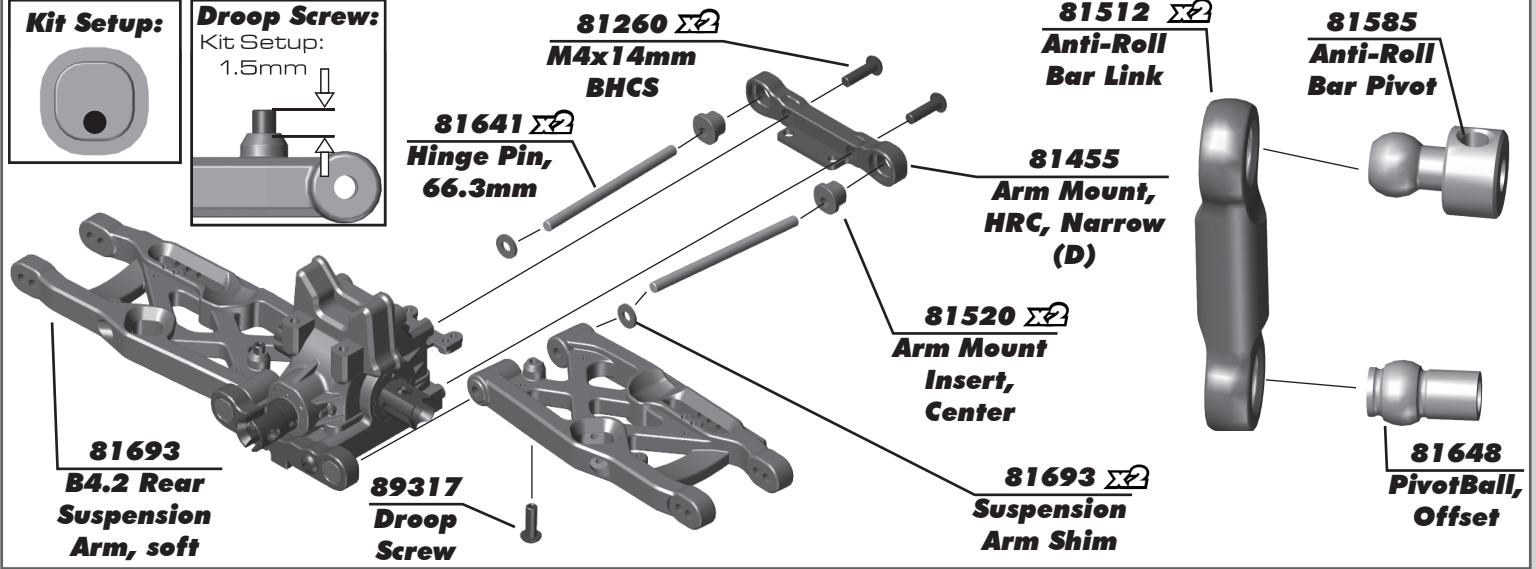

:: Rear End Build - Bag 7.1, 7.2, 7.3 - Step 5

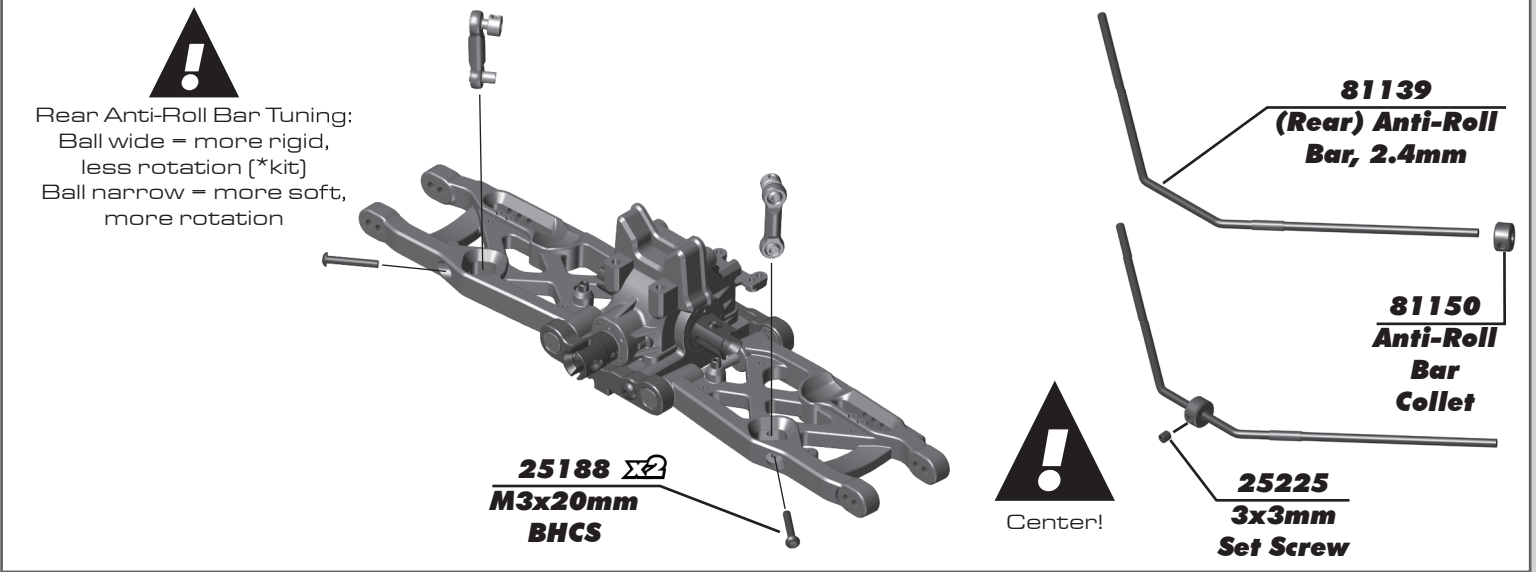

:: Rear End Build - Bag 7.1, 7.2, 7.3 - Step 6

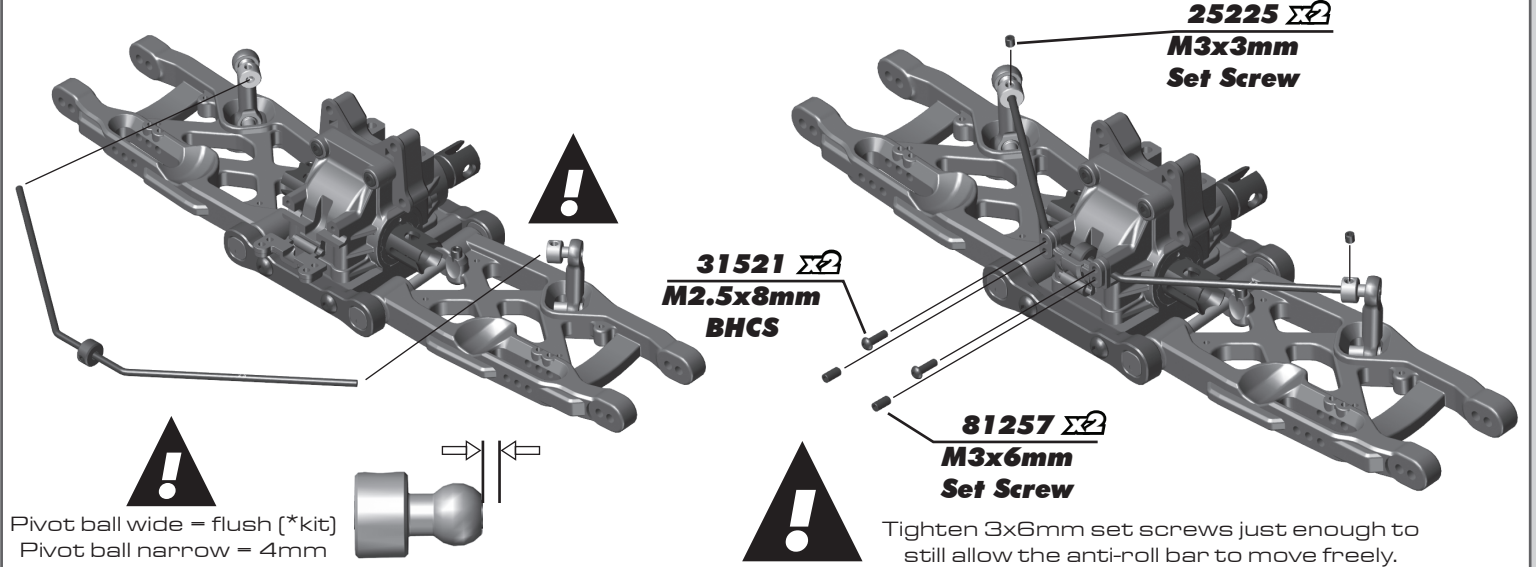

:: Rear End Build - Bag 7.1, 7.2, 7.3 - Step 7

Racer's Tip:
Tune the rear end for more flex with #81562 ball end insert here

81525 Chassis Brace, Rear

25189 3x22mm BHCS

81525 Chassis Brace Mount

81525 Rear Chassis Brace Insert

25612 M3 Locknut W/Flange

89214 M4x12mm FHCS

31532 3x8mm BHCS

81525 Chassis Brace Insert

Check label on chassis brace in this area.

:: Rear End Build - Bag 7.1, 7.2, 7.3 - Step 8

Kit Setup:

81591 FT Shock Bushing, 17mm

89208 M3x14mm FHCS

CHOOSE ONE
Fin adds straight-line stabilization. Button adds agility in corners.

81553 Wing Buttons

81700 High Downforce Wing, Black

81552 Wing Angle Shim, -2

81552 Wing Mount

25215 M3 Locknut

81692 B4.2 Rear Shock Tower

81524 Body Post, Rear

81558 Body Post Grommet

81524 Body Post Mount, Rear

41090 M3x10mm LP SHCS

89227 M3x28mm SHCS

#1596 thread lock

81524 Chassis Brace Insert

:: Rear End Build - Bag 7.1, 7.2, 7.3 - Step 9

Refer to previous step [8] for wing height position

89454 M3x12mm SHCS

81552 Wing Mount Adapter

25215 M3 Locknut

89214 M4x12mm FHCS

89206 M4x10mm BHCS

:: Rear Hubs Build - Bag 8.1, 8.2 - Step 1

Build two!

81469 B3 FT Universals, 92mm

81649 $\Sigma 2$ B4.1 Rear Hub Plates (standard)

25188 $\Sigma 2$ M3x20mm BHCS

25215 $\Sigma 2$ M3 Locknut

81695 B4.2 Rear Hubs, Offset

91564 $\Sigma 2$ 8x16x5mm Bearing

81257 $\Sigma 2$ 3x6mm Set Screw

81079 Wheel Hex, +1mm Wide

89096 Wheel Hex Pin

89221 5x4mm Set Screw

Kit Setup: Tighten set screw before camber link installation.

Racer's Tip: Use a 2mm drill to punch thru the thin wall between set screws and the hinge pin. Tighten after installation to remove slop.

:: Rear Hubs Build - Bag 8.1, 8.2 - Step 2

Install left and right side!

81076 Hub Hinge Pin

81695 $\Sigma 2$ B4.2 Rear Hub Shim, 1mm

25612 M3 Locknut w/Flange

25192 M3x20mm SHCS

25620 M3x10mm SHCS

Kit Setup: B4.2 offset hubs use short arm hole.

:: Rear Hubs Build - Bag 8.1, 8.2 - Step 3

Tuning Tip: Remove screw A for "soft/short" flex configuration.

Kit Setup: Mount the rear shock in the outside hole on the rear arm.

A B

ABC

89216 $\Sigma 2$ M4 Locknut

81264 $\Sigma 2$ M4x20mm FHCS

89214 $\Sigma 2$ M4x12mm FHCS

89217 $\Sigma 2$ M4x14mm FHCS

25612 M3 Locknut W/ Flange

81509 Shock Pin

81257 M3x6mm Set Screw

:: Center Bulkhead - Bag 9.1 - Step 1



Note: Do not use brake rotor guides on center bulkheads

Motor Direction on ESC to Reverse

Weight Bias Setting	FWB	RWB
Center Diff Adapter Position	FWD	RWD
Motor Clamp Position	FWD	RWD
Front Dogbone Shaft (mm)	96.5	104
Rear Dogbone Shaft (mm)	104	96.5

89216 $\Sigma 2$

M4 Locknut

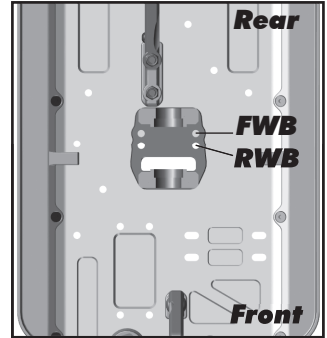

81448 $\Sigma 2$
Center Bulkhead, Lower

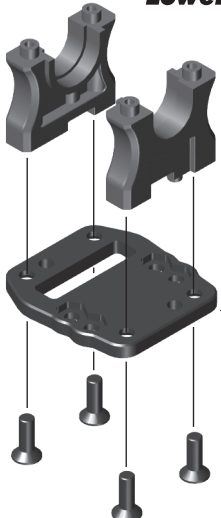

81645
FWB / RWB Adapter Plate

89214 $\Sigma 4$
4x12mm FHCS

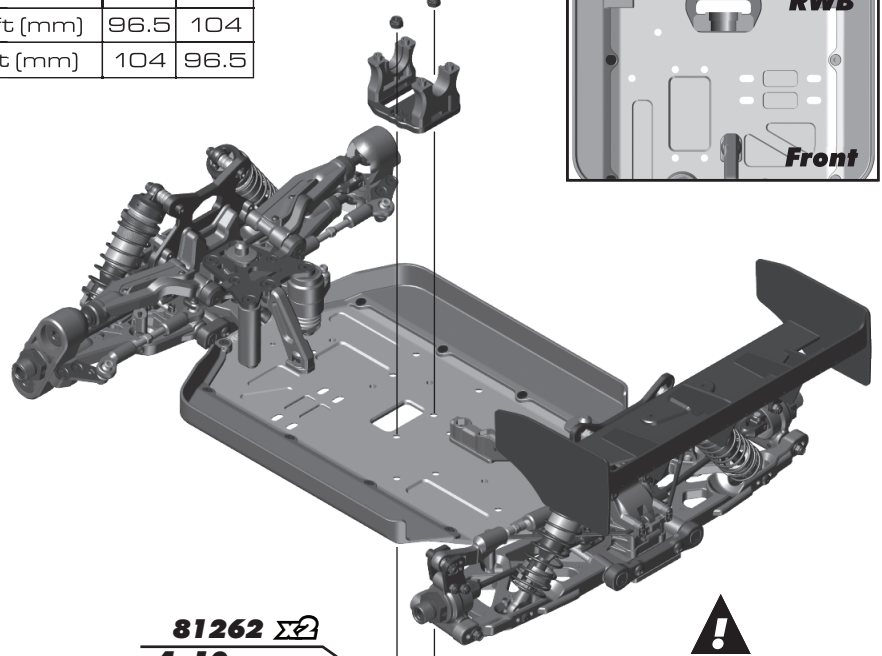

81262 $\Sigma 2$
4x10mm FHCS



Note: The upper center bulkheads have "F" for front and "R" for rear.

:: Center Bulkhead - Bag 9.1 - Step 2

89212 $\Sigma 4$
3x30mm FHCS

81581
RC8B4e Center Dogbone, 104mm

81578
RC8B4e Front Top Plate

81448 $\Sigma 2$
Center Bulkhead, Upper

81646
RC8B4e Center Dogbone, 96.5mm

31521 $\Sigma 2$
2.5x8mm BHCS

81572
RC8B4e Wire Routing Clips

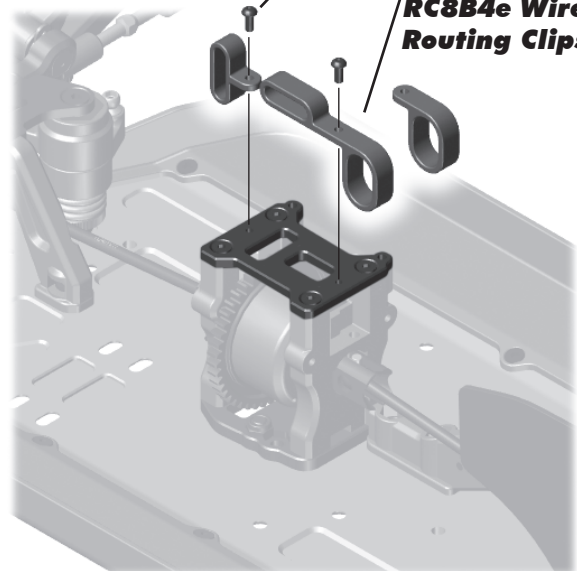
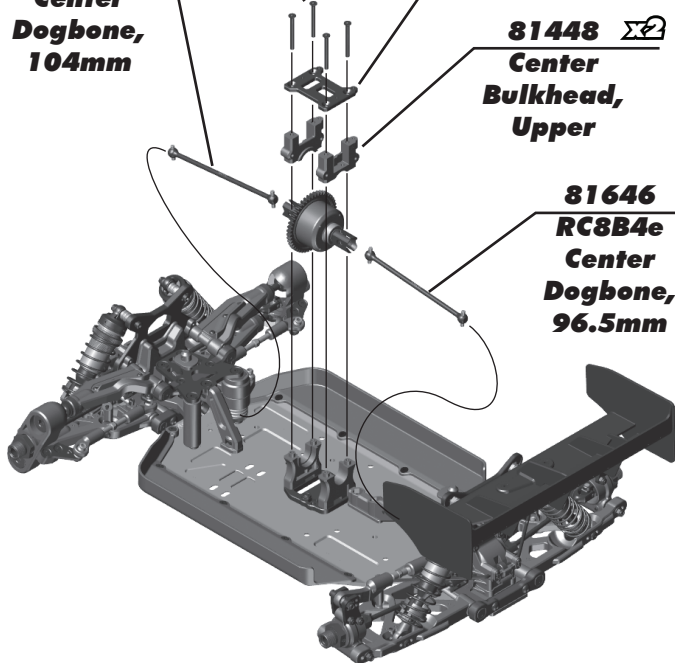

:: Center Bulkhead - Bag 9.1 - Step 3

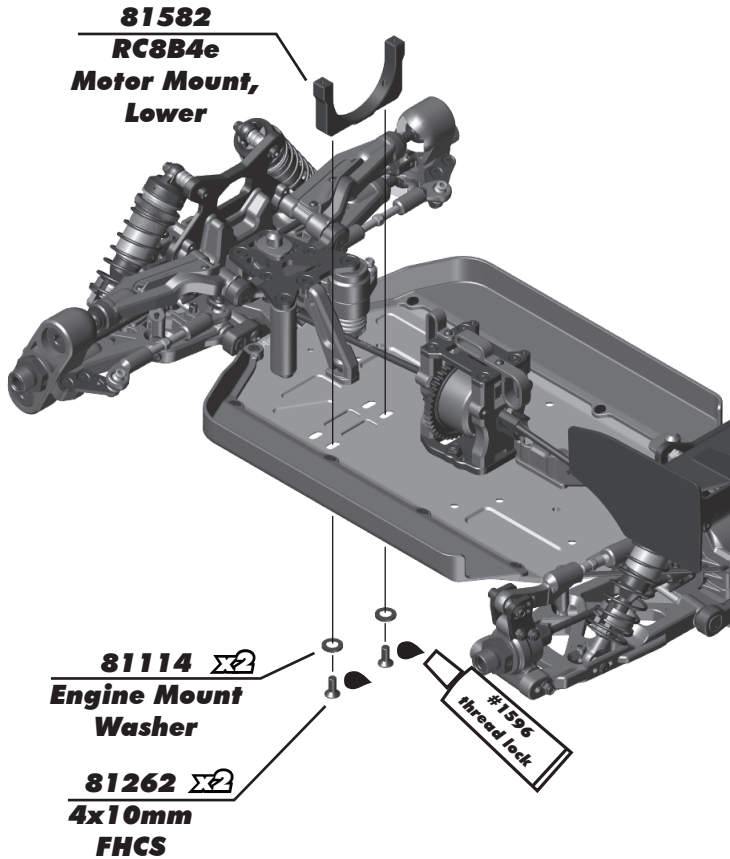

Optional!
30mm fan
(not included)

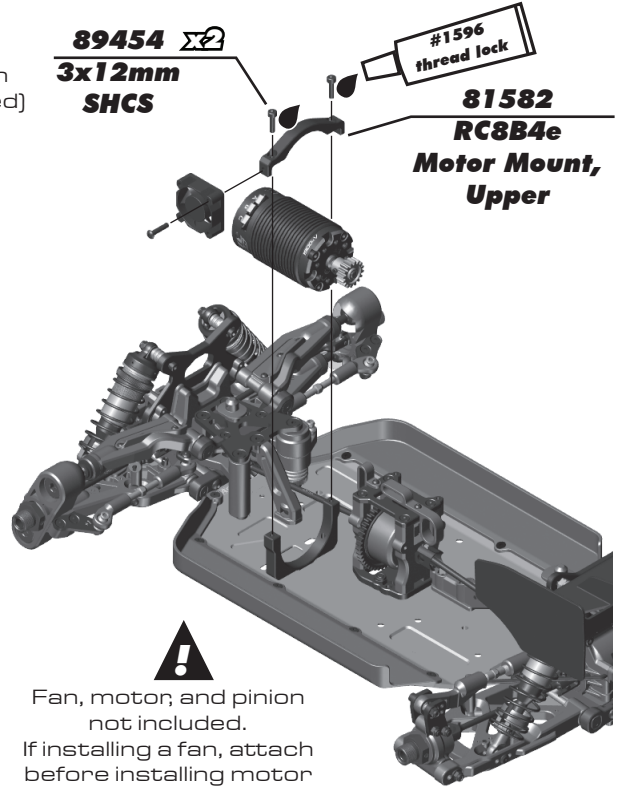

Fan, motor, and pinion not included.
If installing a fan, attach before installing motor mounts.
Hardware not included.
Maximum screw depth 4mm.

:: Radio Tray Build - Bag 10.1, 11.1 - Step 1

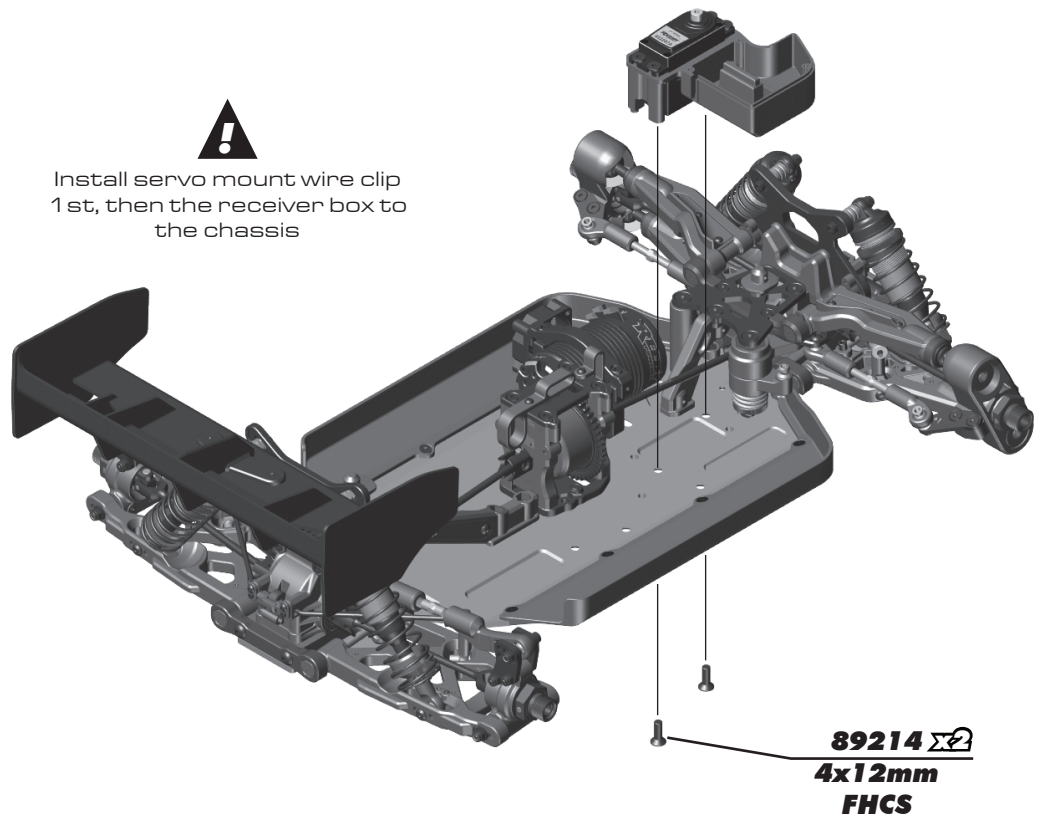
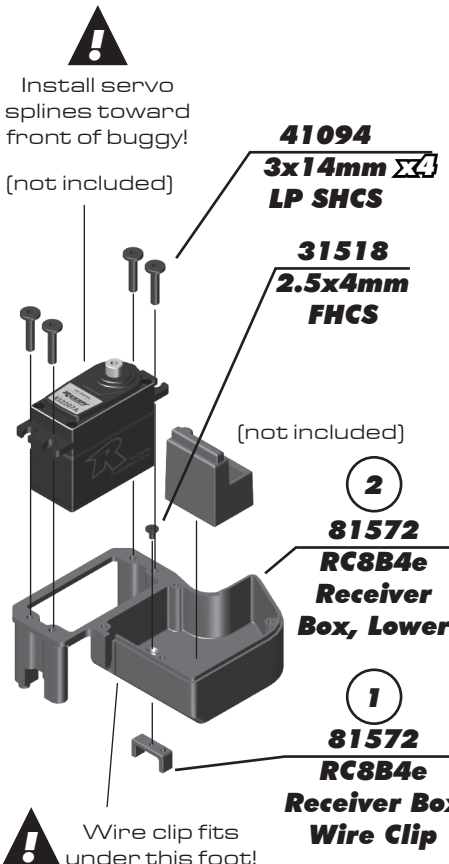

:: Radio Tray Build - Bag 11.1 - Step 2

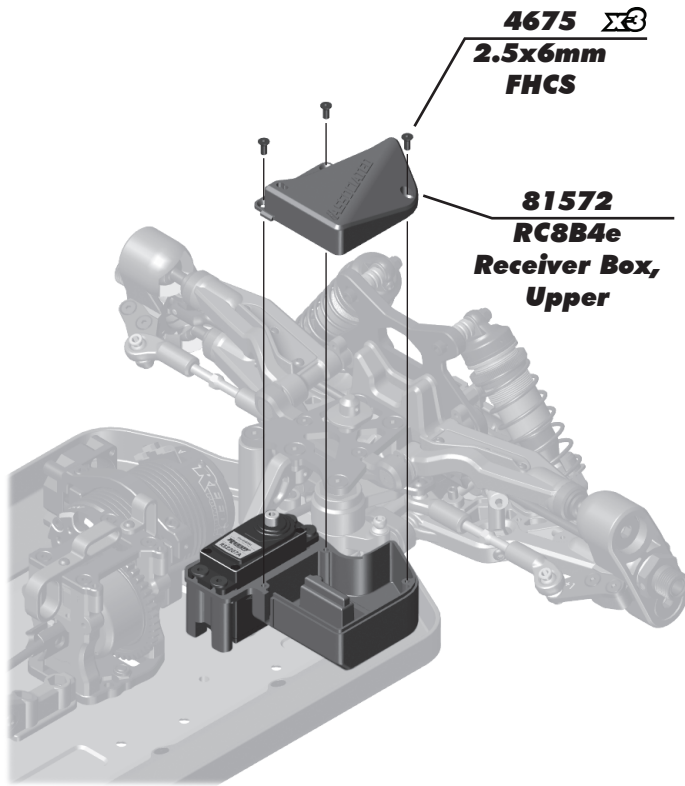

4675 $\Sigma 3$
2.5x6mm
FHCS

81572
RC8B4e
Receiver Box,
Upper

Spline Count



Printed here
23T
25T

81556
Servo Horn
(Steering)

25215
M3
Locknut

81556
Servo Horn
Insert

91048
HD Ball
Stud, 8mm

:: Radio Tray Build - Bag 11.1 - Step 3

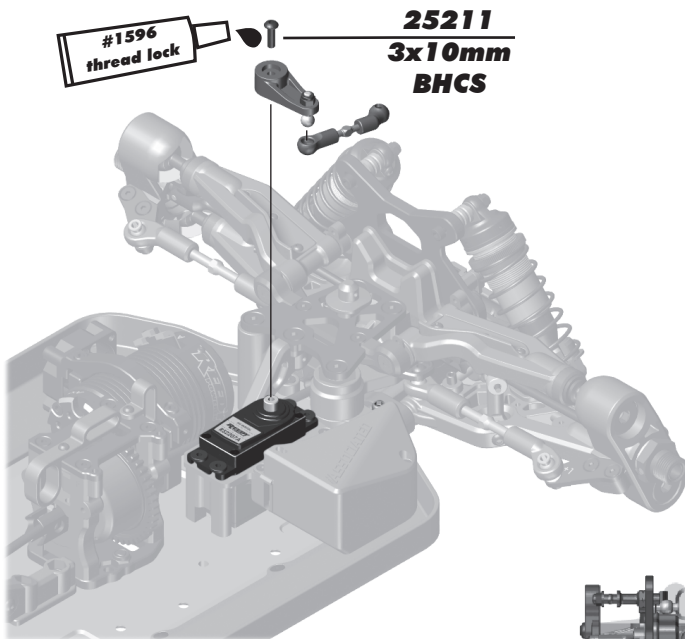

#1596
thread lock

25211
3x10mm
BHCS



To build RC8B4.2e for use with two 2s shorty battery packs in a "saddle" configuration, follow the steps below.

To build RC8B4.2e for use with one 4s shorty battery pack, continue to "Battery Tray Build - Bag 12.1 - Step 2"

2s Shorty Pack Configuration

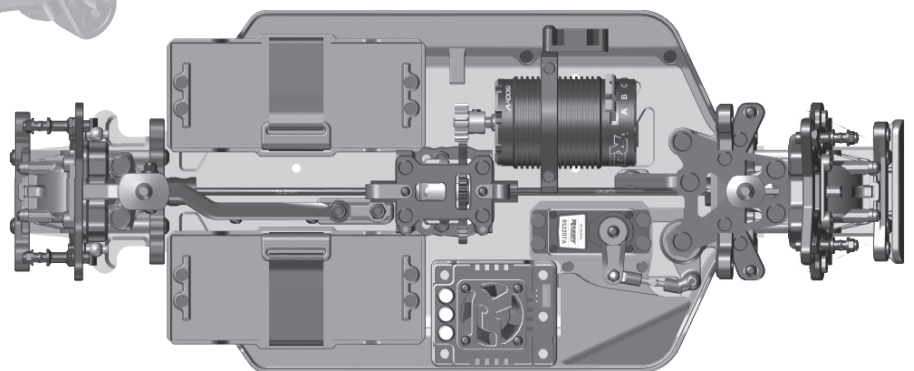

:: Battery Tray Build - Bag 12.1 - Step 1



!!!ALERT!!!

ESC Setup needs motor rotation = REV
Reverse Motor Rotation only



Reverse ESC in program box

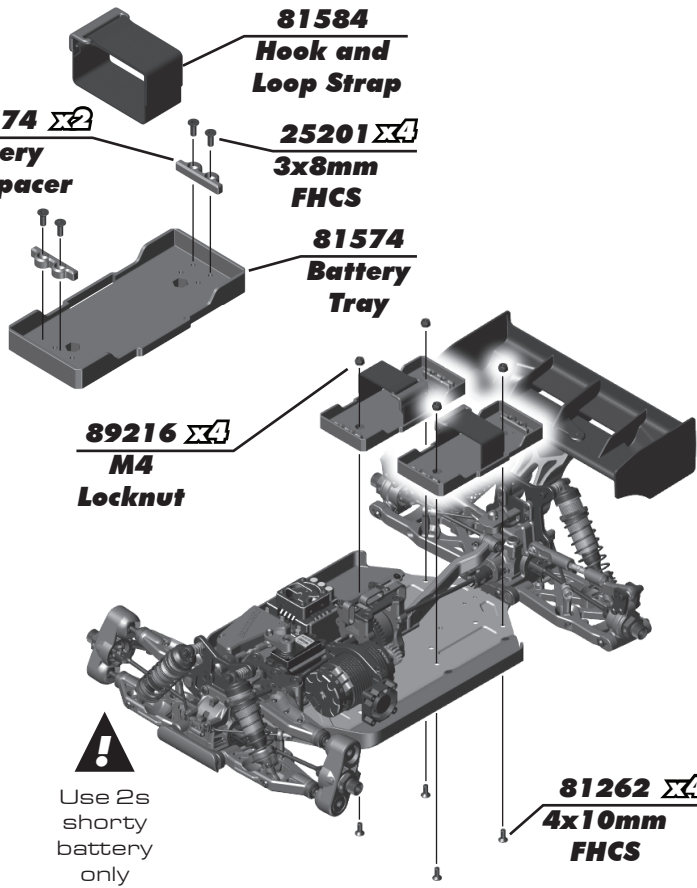
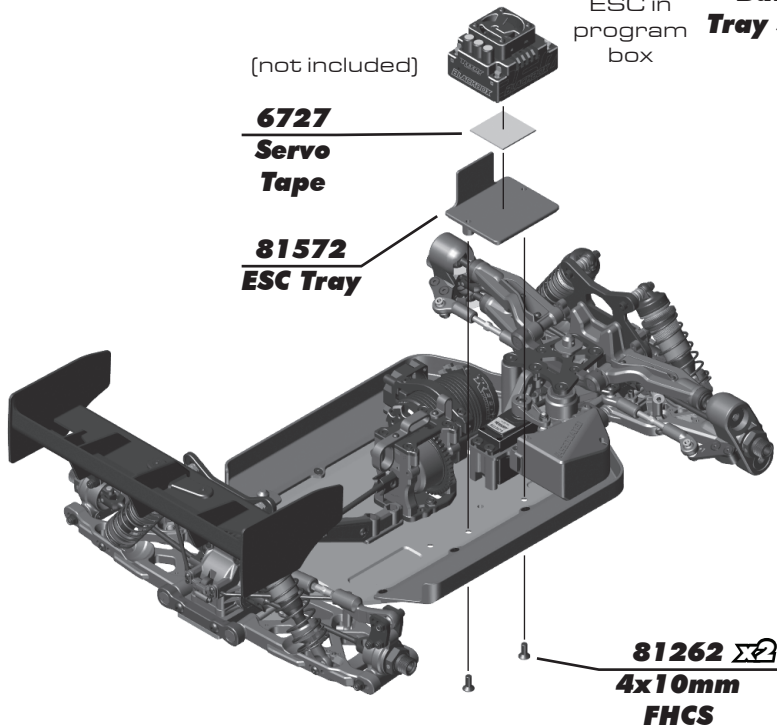

:: Battery Tray Build - Bag 12.1 - Step 2

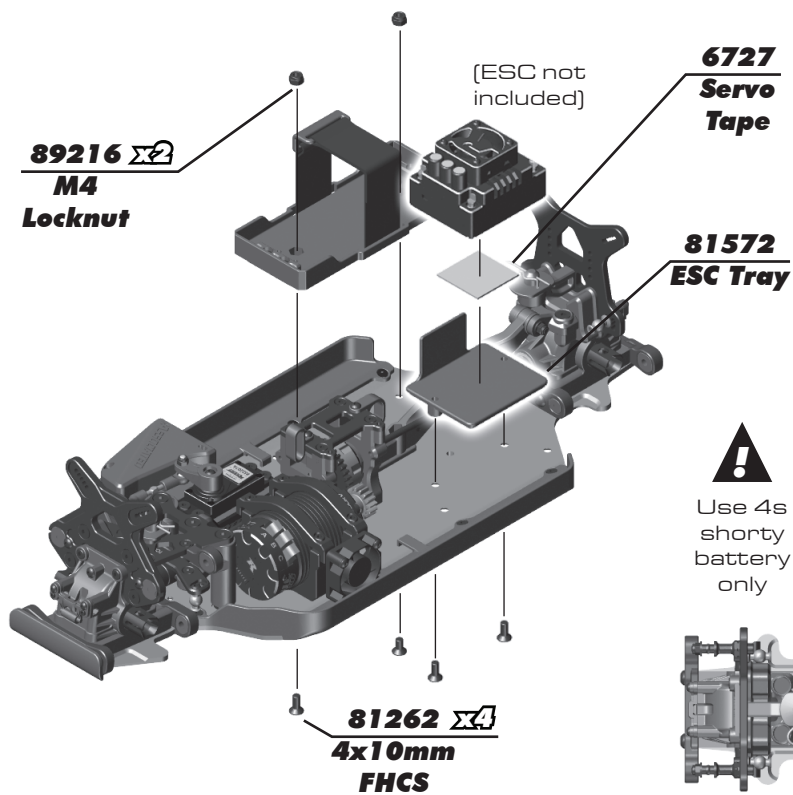

!! ALERT !!

4s Shorty pack configuration does not fit with the kit body (#81568).

Fits with optional brand bodies that clear the taller cell configuration.



Use 4s shorty battery only

4s Shorty Pack Configuration

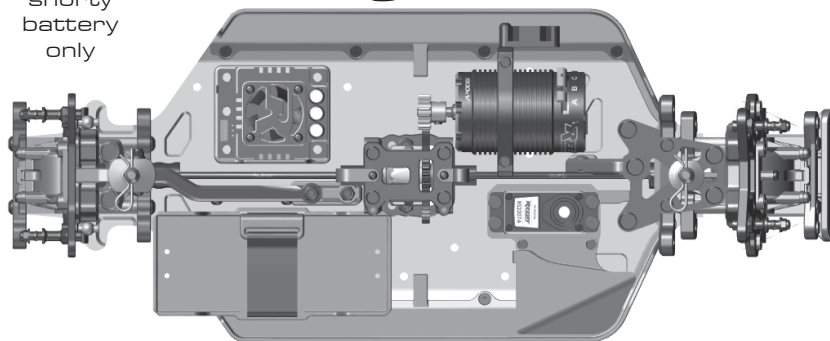

:: Wheels / Tires / Body - Misc. - Step 2



Install wheel nuts with the serrated edge towards the wheel.

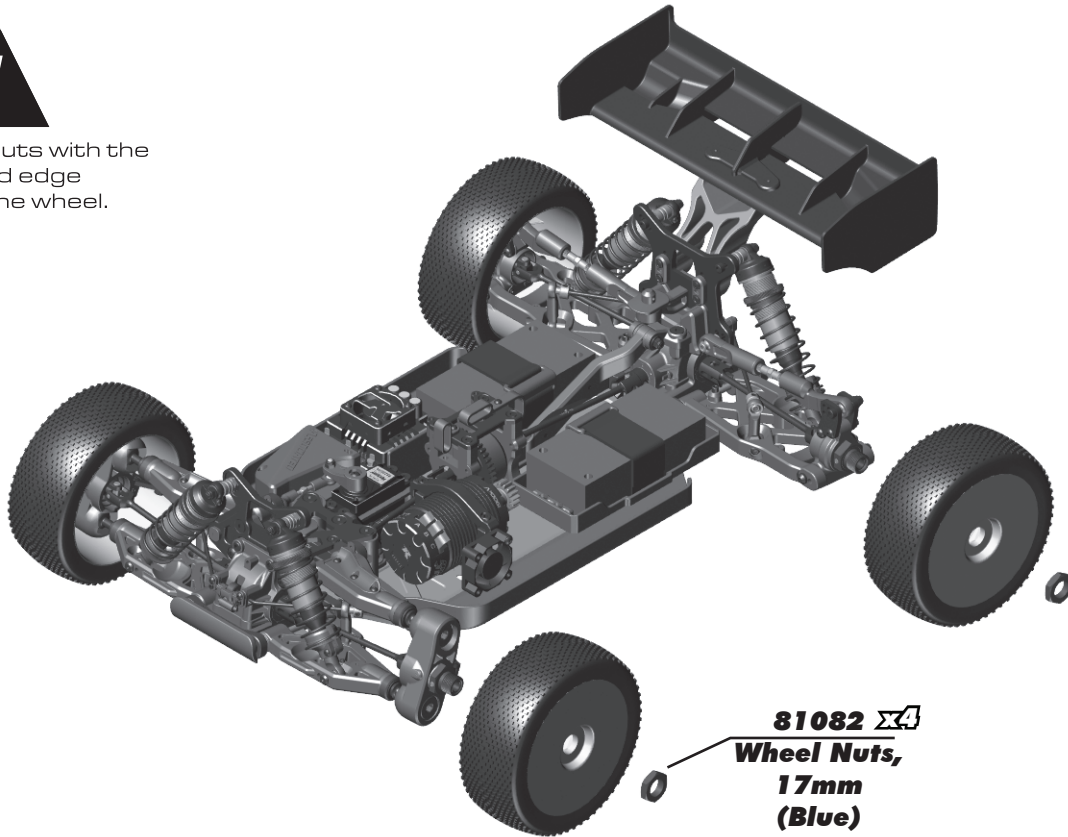

81082 
Wheel Nuts,
17mm
(Blue)

:: Wheels / Tires / Body - Misc. - Step 3



Final chassis ride height.
 Front = 23mm
 Rear = 26mm

81568
Body

2208 
Body Clip

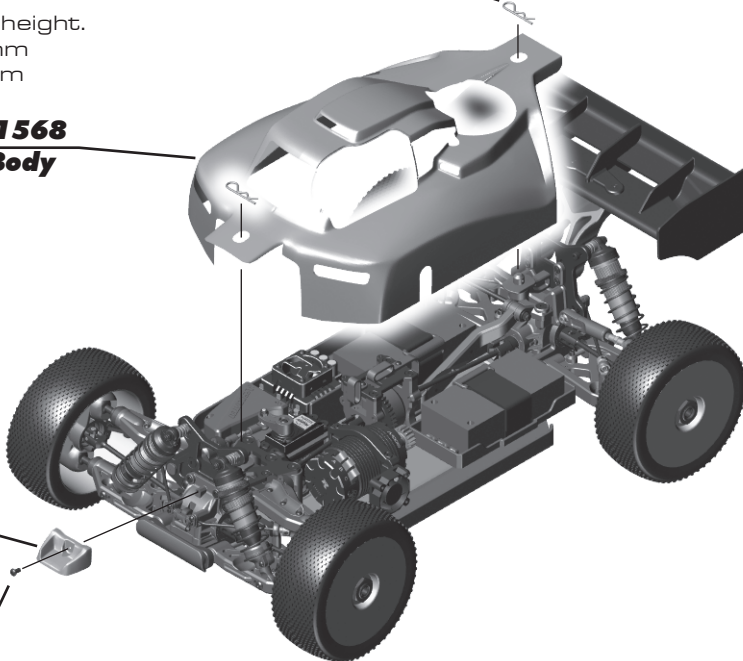

81583
Nose
Cone

31531
3x6mm
BHCS

Painting Tips:

Your kit comes with a clear polycarbonate body. You will need to prep the body before you can paint it. Wash the inside thoroughly with warm water and liquid detergent. Dry the body using a clean, soft, lint-free cloth. Install the window masks on the inside of the body. (R/C cars get painted from the inside). Using high quality masking tape, apply tape to the inside of the body to create a design. Spray (either rattle can or airbrush R/C specific paint) the paint to the inside of the body (preferably dark colors first, lighter colors last).

NOTE: use ONLY paint that is recommended for use with (polycarbonate) plastics. If you do not, you can destroy the polycarbonate body!!!

After painting, cut the body along the trim lines. Make sure to drill or use a body reamer to make the holes for the body mounts and antenna!

:: Droop Settings

Set droop by measuring overall length of shock (from standoff to shock pin) while the chassis is elevated above your working surface. The shocks should be fully extended.

Kit setup for front droop is 101mm shock length, and 126mm shock length for the rear using "C" hole.

If the shock length is too long, adjust by turning the droop screws clockwise.

If the shock length is too short, adjust by turning the droop screws counter-clockwise.

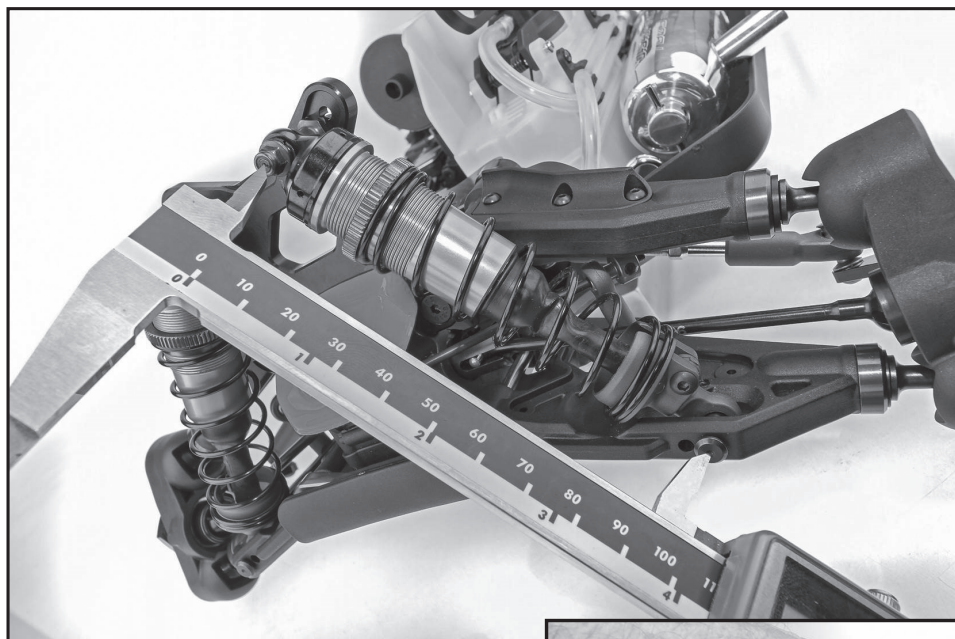

Racer's Tip:

Use 123mm for the middle "B" rear arm hole, and +2 or 0 eyelet.

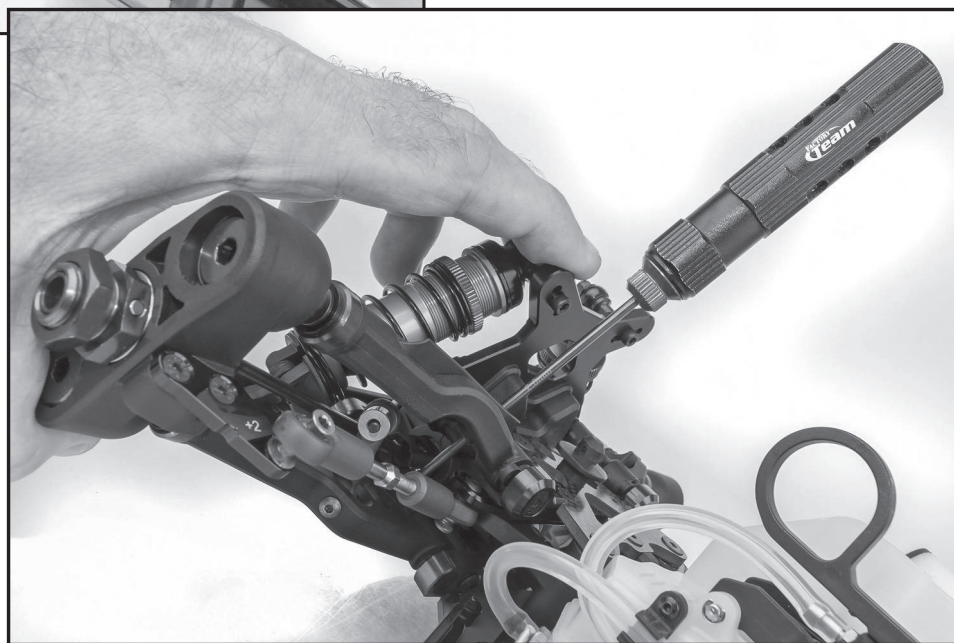

Front Droop: Increasing front droop (loosen droop screws) will increase off-throttle steering. It also allows the front end to lift more, giving more rear grip and less front grip on-power. Remember to never loosen the screws beyond the FULL DROOP setting. Decreasing front droop (tighten droop screws) yields more on-power steering and quicker response at the expense of some stability in bumpy sections. It will also give less off-throttle steering.

Rear Droop: Increasing rear droop (loosen droop screws) will increase traction in bumpy sections, but will reduce high-speed stability. Remember to never loosen the screws beyond the FULL DROOP setting. Decreasing rear droop (tighten droop screws) will increase stability in high speed sections, but will reduce stability in bumpy sections.

Setup Sheets:

To find different setups for your kit, visit our website, <https://www.associatedelectrics.com/teamassociated/> and click on the "Setup Sheets" link, and then the link to your model. Our team of professional drivers help develop these setups at races worldwide. Additionally, most drivers have a "base" setup that they use as a starting point for most races. Try running some of our base setups or look for track conditions and tires that are similar to your local track and replicate that setup. Remember, each adjustment has a purpose, so copy everything from the setup sheet and then make adjustments based on the recommendations in here.



Associated Electrics, Inc.
21062 Bake Parkway Lake Forest, CA 92630 USA

call: (949) 544-7500 - fax: (949) 544-7501
***Check out the following web sites for all of our kits, current products,
new releases, setup help, tips, and racing info!***
www.AssociatedElectrics.com

FOLLOW US ON SOCIAL MEDIA



TeamAssociated
ReedyPower
ElementRC
FactoryTeam51



@TeamAssociatedRC
@ReedyPower
@Element_RC
@FactoryTeam_RC



@Team_Associated
@ReedyPower



@Associated_Electrics



TeamAssociatedRC
ElementRC



TeamAssociated
Reedy
Element-rc