

# RC B TEAM **B4.2e** KIT

1:8 Scale 4WD Electric Off Road  
Competition Buggy Kit

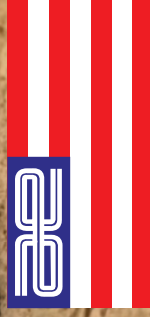

# TEAM ASSOCIATED



1:8 Scale 4WD Electric Off Road Competition Buggy Kit Manual

#80955 RC10B4.2e Team Kit



**CHAMPIONS** *by* DESIGN

[AssociatedElectrics.com](http://AssociatedElectrics.com)

# TEAM ASSOCIATED

## :: Introduction

Thank you for purchasing this Team Associated product. This assembly manual contains instructions and tips for building and maintaining your new Kit. Please take a moment to read through this manual to help familiarize yourself with these steps. We are continually changing and improving our designs; therefore, actual parts may appear slightly different than in the illustrations. New parts will be noted on supplementary sheets located in the appropriate parts bags. Check each bag for these sheets before you start to build.

## :: KIT Features

Features in the RC8B4.2e Kit:

- New molded height-adjustable gearboxes front and rear
- New offset hubs and updated rear suspension arms to accommodate new hub geometry
- New high-volume center differential
- New high-downforce wing
- Now includes FT hard-anodized aluminum shock bushings
- RWB/FWB adjustable weight bias chassis
- Soft blend material suspension arms
- 8-degree KPI steering blocks included
- 44/13 ring and pinion gear sets
- 92mm universal driveshafts with 17mm outdrives
- Both 19mm and 20mm diameter HTC internal differential gear sets included
- 47T machined steel spur gear included
- Centralized drivetrain and chassis configuration optimized for shorty-style batteries
- Adjustable battery tray design with hook and loop strap for retaining batteries
- Includes both stiff shock bladders and emulsion seals

## :: Additional

Your new RC8B4.2e Kit comes as a kit. There are items you will need to complete your kit (refer to the website for suggestions):

- |   |                           |                         |
|---|---------------------------|-------------------------|
| • 2 or 3 channel radio/transmitter (2.4GHz recommended) | • Transmitter batteries   | • Steering servo        |
| • Two 2s or One 4s LiPo Battery Pack                    | • 1/8th scale sized motor | • 1/8th scale sized ESC |
| • Polycarbonate-specific paint                          | • Thread-locking compound | • Needle-nose pliers    |
| • 1:8 scale buggy tires and wheels                      | • CA (cyanoacrylic) glue  | • Hobby knife           |
| • Reamer / hole punch                                   | • Ride height gauge       |                         |

## :: Other Helpful Items

- |  |   |
|--|---|
| • Silicone Shock/Diff Fluids (Refer to the website for complete listings): | • Body Scissors (AE #1737)                |
| • Shock Pliers   | • FT Hex Wrenches / Nut Drivers - (#1519) |
| • Reamer / Hole Punch - (#1499)  | • Calipers or a Precision Ruler           |
| • Ride Height Gauge  | • Wheel Nut Wrench 17mm - (#1571)         |
| • FT Hex Wrenches - (#1506, 1518)  |   |
| • Wire Cutters   |   |
| • Turnbuckle Wrench - (#1114)  |   |

**Associated Electrics, Inc.**  
21062 Bake Parkway  
Lake Forest, CA 92630



**Customer Service**  
Tel: 949.544.7500  
Fax: 949.544.7501

**:: Hardware - 1:1 Scale View**

**Flat Head (fhcs)**

	<b>2.5x6mm (4675)</b>
	<b>2.5x8mm (31448)</b>
	<b>3x5mm (31540)</b>
	<b>3x6mm (31541)</b>
	<b>3x8mm (25201)</b>
	<b>3x10mm (25202)</b>
	<b>3x12mm (25203)</b>
	<b>3x14mm (89208)</b>
	<b>3x30mm (89212)</b>
	<b>4x10mm (81262)</b>
	<b>4x12mm (89214)</b>
	<b>4x14mm (89217)</b>
	<b>4x16mm (81263)</b>
	<b>4x20mm (81264)</b>

**Button Head (bhcs)**

	<b>2.5x6mm (31520)</b>
	<b>2.5x8mm (31521)</b>
	<b>2.5x18mm (81259)</b>
	<b>3x6mm (31531)</b>
	<b>3x8mm (31532)</b>
	<b>3x10mm (25211)</b>
	<b>3x12mm (89202)</b>
	<b>3x14mm (25187)</b>
	<b>3x16mm (89203)</b>
	<b>3x18mm (2308)</b>
	<b>3x20mm (25188)</b>
	<b>3x22mm (25189)</b>
	<b>3x24mm (89204)</b>
	<b>4x14mm (81260)</b>
	<b>4x16mm (81261)</b>

**Set Screws**

	<b>3x3mm (25225)</b>
	<b>3x6mm (81257)</b>
	<b>3x10mm (4671)</b>
	<b>3x12mm (81258)</b>
	<b>4x4mm (7732)</b>
	<b>5x4mm (89221)</b>

**Socket Head (shcs)**

	<b>2x5mm (31511)</b>
	<b>2x16mm (7184)</b>
	<b>3x10mm (25620)</b>
	<b>3x12mm (89454)</b>
	<b>3x24mm (89225)</b>
	<b>3x26mm (89226)</b>
	<b>3x28mm (89227)</b>

**LP Socket Head (lp shcs)**

	<b>3x6mm (41089)</b>
	<b>3x10mm (41090)</b>
	<b>3x14mm (41094)</b>
	<b>3x16mm (41093)</b>
	<b>3x20mm (41091)</b>

**Ball Bearings**

	<b>5x8x2.5mm (8680)</b>
	<b>5x10x4mm (91560)</b>
	<b>6x10mm (31404)</b>
	<b>6x12x4mm (91561)</b>
	<b>8x16x5mm (91564)</b>
	<b>8x16x5mm flanged (91565)</b>

**Nuts (lock/plain)**

	<b>M3 Nut (91477)</b>
	<b>M3 Alum. Locknut, Blue (31550)</b>
	<b>M3 Locknut, Black (25215)</b>
	<b>M3 Locknut w/Flange (25612)</b>
	<b>FT 3mm Locknuts, Blue(25392)</b>
	<b>FT M4 Locknut, Blue (31551)</b>
	<b>M4 Locknut, Serrated (91738)</b>

## :: Table of Contents

1..... Cover	16 - 18.....Rear End Build (Bags 7.1, 7.2, 7.3)
2..... Introduction	19.....Rear Hubs Build (Bags 8.1, 8.2)
3..... 1:1 Hardware "Fold Out"	20 - 21.....Center Bulkhead Build (Bag 9.1)
4..... Table of Contents	21 - 22.....Radio Tray Build (Bag 10.1, 11.1)
5 - 7.....Differentials Build (Bags 1.1, 1.2)	22 - 23.....Battery Tray Build (Bag 12.1)
7 - 8.....Shocks Build (Bag 2.1)	24.....Wheels / Tires / Body (Misc.)
9.....Turnbuckles Build (Bags 3.1)	25.....Droop Settings
10 - 11.....Steering / Chassis Build (Bag 4.1)	26.....Back Cover
11 - 14.....Front Gearbox Build (Bags 5.1, 5.2, 5.3)	
14 - 15.....Steering Blocks Build (Bags 6.1)	

## :: Notes



**This symbol indicates a special note or instruction in the manual.**



**This symbol indicates a specific build order in the manual.**



**This symbol indicates a Racers Tip.**



**There is a 1:1 hardware foldout page in the front of the manual. To check the size of a part, line up your hardware with the correct drawing until you find the exact size. Each part in the foldout has a number assigned to it for ordering replacement parts.**

Associated Electrics, Inc.  
21062 Bake Parkway  
Lake Forest, CA 92630



Customer Service  
Tel: 949.544.7500  
Fax: 949.544.7501

**:: Differential Build (Front and Rear) - Bag 1.1, 1.2 - Step 1**

**#6588 black grease**

**81697 Outdrive O-Ring 5.8x1.9mm**

**81379 Diff Case**

**91564 8x16x5 Bearing**

**81381 Diff Shim 6x8x0.20mm**

**#6588 black grease**

**81012 17mm Outdrive**

**81681 Pin 2.5x12mm**

**81681 Diff Sun Gear, 19mm HTC**

Note: Both 81681 19mm HTC and 81380 20mm HTC Sun Gears included.  
**DO NOT MIX!**

All 19mm HTC gears (81681) are kit setup.

**!**  
Align pin with groove in sun gear

**:: Differential Build (Front and Rear) - Bag 1.1, 1.2 - Step 2**

**81681 x4 Diff Planet Gears, 19mm and 20mm HTC**

**81681 x2 Diff Crosspin**

**81681 x4 Diff Shim 3.6x12x0.12mm**

**#6588 black grease**

**81468 Diff Ring Gear, 44/13 Set**

**81697 Outdrive O-Ring 5.8x1.9mm**

**91564 8x16x5 Bearing**

**81381 Diff Shim 6x8x0.20mm**

**#6588 black grease**

**81012 17mm Outdrive**

**:: Differential Build (Front and Rear) - Bag 1.1, 1.2 - Step 3**

**81681 Pin 2.5x12mm**

**81681 Diff Sun Gear, 19mm HTC**

**81384 Diff Gasket**

**#6588 black grease**

**!**  
Align pin with groove in sun gear

**Racer's Tip:**  
Use black grease (#6588) to coat the back side of the diff gasket [i.e. not the entire gasket] before installation!

**:: Differential Build (Front and Rear) - Bag 1.1, 1.2 - Step 4**



**Racer's Tip:**

Fill diff above the cross pins, below the planet gears as shown.

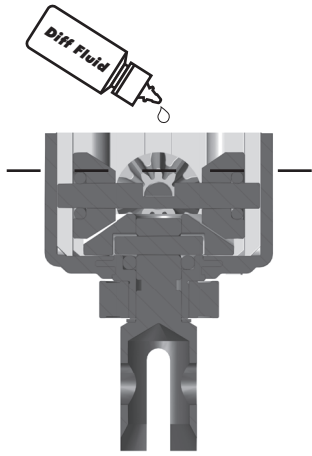

**25202 X4**  
**M3x10mm**  
**FHCS**

**Front Diff Fluid:**  
**15,000cst #5447**

**Rear Diff Fluid:**  
**5,000cst #5453**

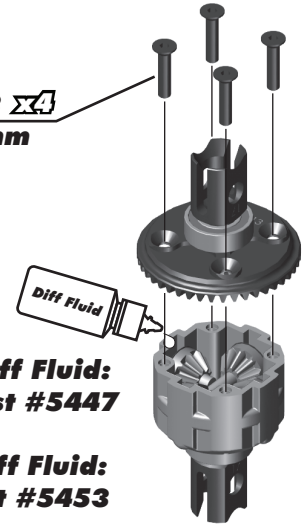

**:: Differential Build (Center) - Bag 1.1, 1.2 - Step 5**

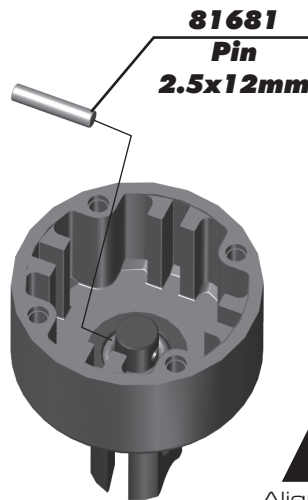
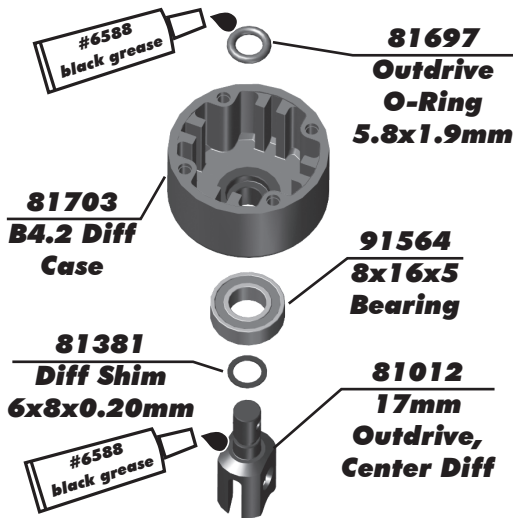

Align pin with groove in sun gear

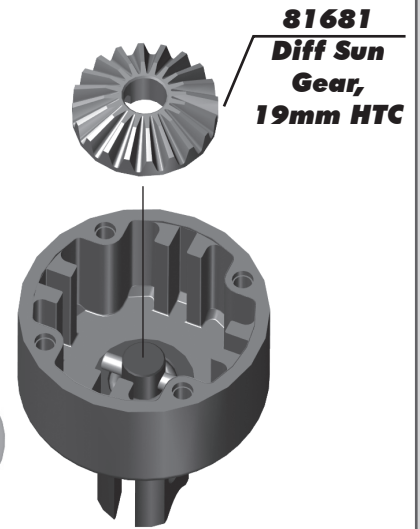

**:: Differential Build (Center) - Bag 1.1, 1.2 - Step 6**

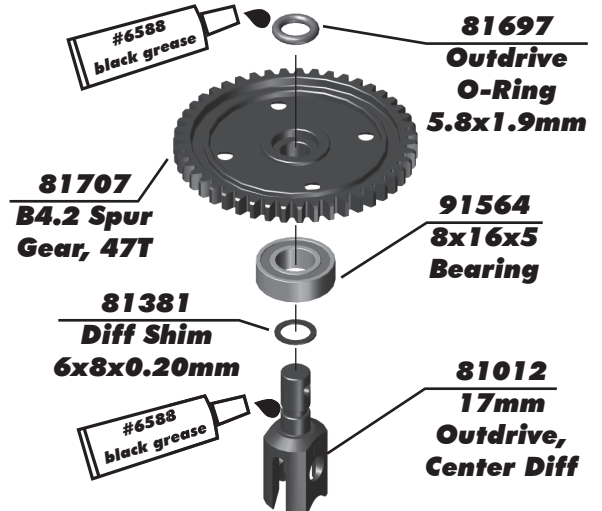
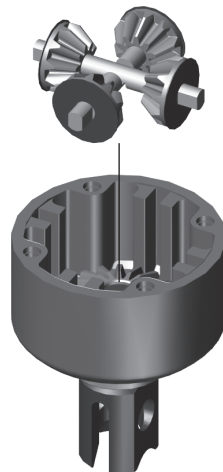
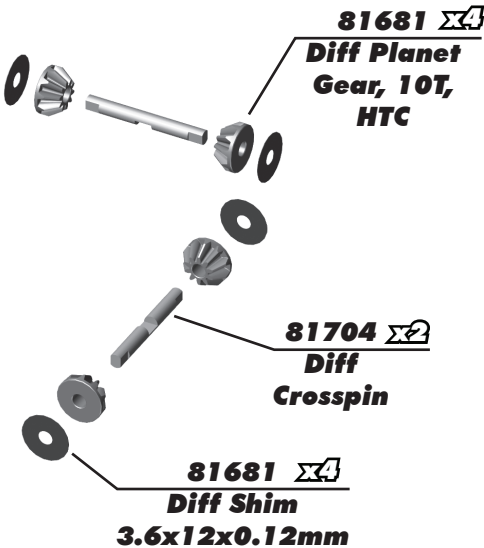

**:: Differential Build (Center) - Bag 1.1, 1.2 - Step 7**

**81681 Pin 2.5x12mm**

**81681 Diff Sun Gear, 19mm HTC**

**81705 B4.2 Center Diff Gasket, 0.5mm**

**#6588 black grease**

**Racer's Tip:**  
Use black grease (#6588) to coat the back side of the diff gasket (i.e. not the entire gasket) before installation!

Align pin with groove in sun gear

**:: Differential Build (Center) - Bag 1.1, 1.2 - Step 8**

**Racer's Tip:**  
Fill diff above the cross pins, below the planet gears as shown.

**Diff Fluid**

**25202 x4 M3x10mm FHCS**

**Center Diff Fluid:**  
**10,000cst #5455**

**:: Shocks Build - Bag 2.1 - Step 1**

**81202 FT Shock Piston (6x1.3 flat) Front**

**89215 2.5mm Shock Piston Locknut**

**89278 2.6x6mm Washer**

**81172 TiN Shock Shaft, 3.5x33.5mm (Front)**

**81173 TiN Shock Shaft, 3.5x42.5mm (Rear)**

**81162 Shock Body, 26.5mm (Front)**

**81163 Shock Body, 36.5mm (Rear)**

**81185 Shock Body O-Ring**

**81185 O-Ring Hat Bushing**

**81188 Shock Body Seal Retainer**

**81186 Shock O-Ring**

**81185 O-Ring Spacer**

**81597 FT Shock Piston (6x1.4 tapered) Rear**

**Install pistons taper down**

**:: Shocks Build - Bag 2.1 - Step 2**

**Racer's Tip:**  
Use green slime (#1105) to lube the o-rings before installation!

**81190 Shock Boots**

**81562 Rod End Ball**

**81452 RC8B3.2 Shock Cap**

**81621 Shock Rod End**  
Front: +2  
Rear: +2

**81512 Shock Cap Insert**

**91492 2x4mm BHCS**

**91492 Gasket (2)**

**81184 Emulsion Seal (1)**

**Option Included: 81453 16mm Stiff Bladder**

When installing the emulsion seal, make sure it is correctly seated within the shock cap as shown.

**:: Shocks Build - Bag 2.1 - Step 3**

**Fill to top of shock body.**

**Front Shock Fluid: 40wt #5423**

**Rear Shock Fluid: 35wt #5429**

Tighten to snug, may be a small gap when sealed.

**Bleed Procedure:**  
Remove bleeder screw  
Tilt shock so bleed hole is the highest point and slowly compress the shaft.

Stop about 3mm from full compressed, install the screw, and check that the shock is not pressurized. If so, bleed out a small amount more.

**:: Shocks Build - Bag 2.1 - Step 4**

The springs come with a colored marking pre-installed for easy identification

**81221 Spring Collar O-Ring, 20mm**

**81221 Spring Collar, 20mm**

**81659 Front Spring, Green (4.85lb/in) L68, 8.00T, 1.5D**

**81663 Rear Spring, Green (3.60lb/in) L83, 10.00T, 1.5D**

**81512 Spring Cup**

**25211 3x10mm BHCS**

**:: Turnbuckles Build - Bag 3.1 - Step 1**

**Steering Servo Turnbuckle**

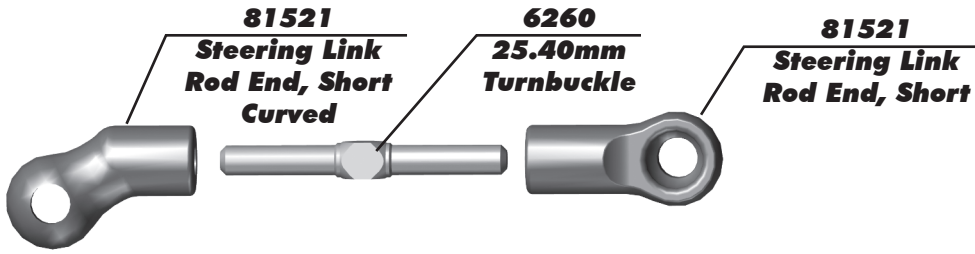

  
Set aside until page 22

**11.50mm (0.45")**

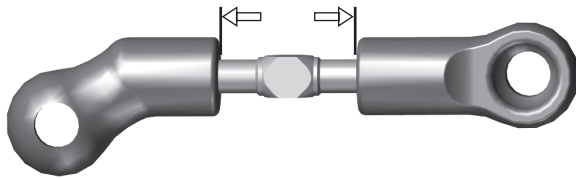

**:: Turnbuckles Build - Bag 3.1 - Step 2**

**Steering Turnbuckle**

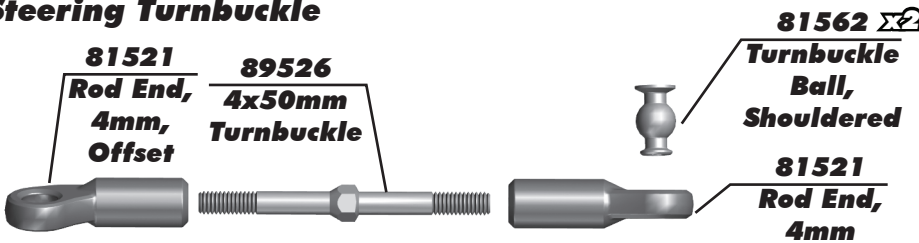

  
Note the direction of turnbuckle ball



**24.20mm (0.952")**

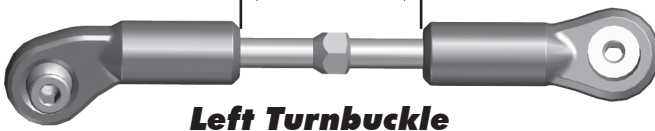

**Left Turnbuckle**

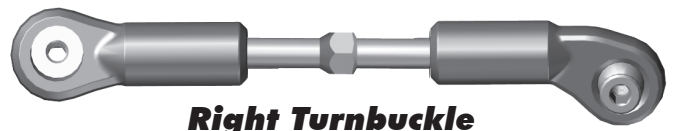

**Right Turnbuckle**

  
Set aside until page 15

**:: Turnbuckles Build - Bag 3.1 - Step 3**

**Rear Hub Turnbuckle**

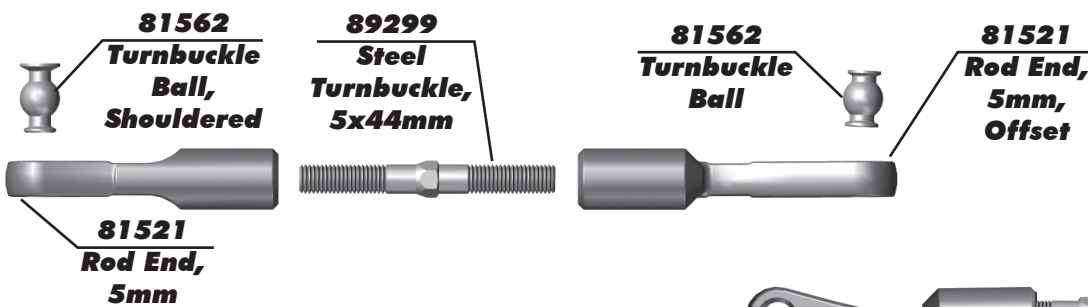

  
Set aside until page 19

**13.70mm (0.539")**

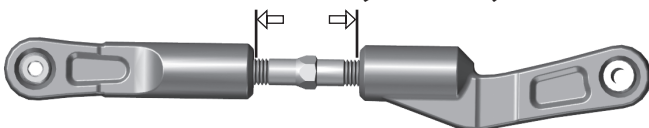

**Left Turnbuckle**

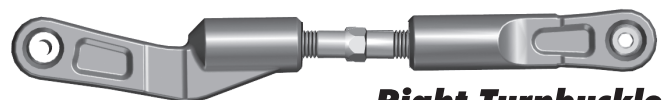

**Right Turnbuckle**

**:: Steering / Chassis Build - Bag 4.1 - Step 1**

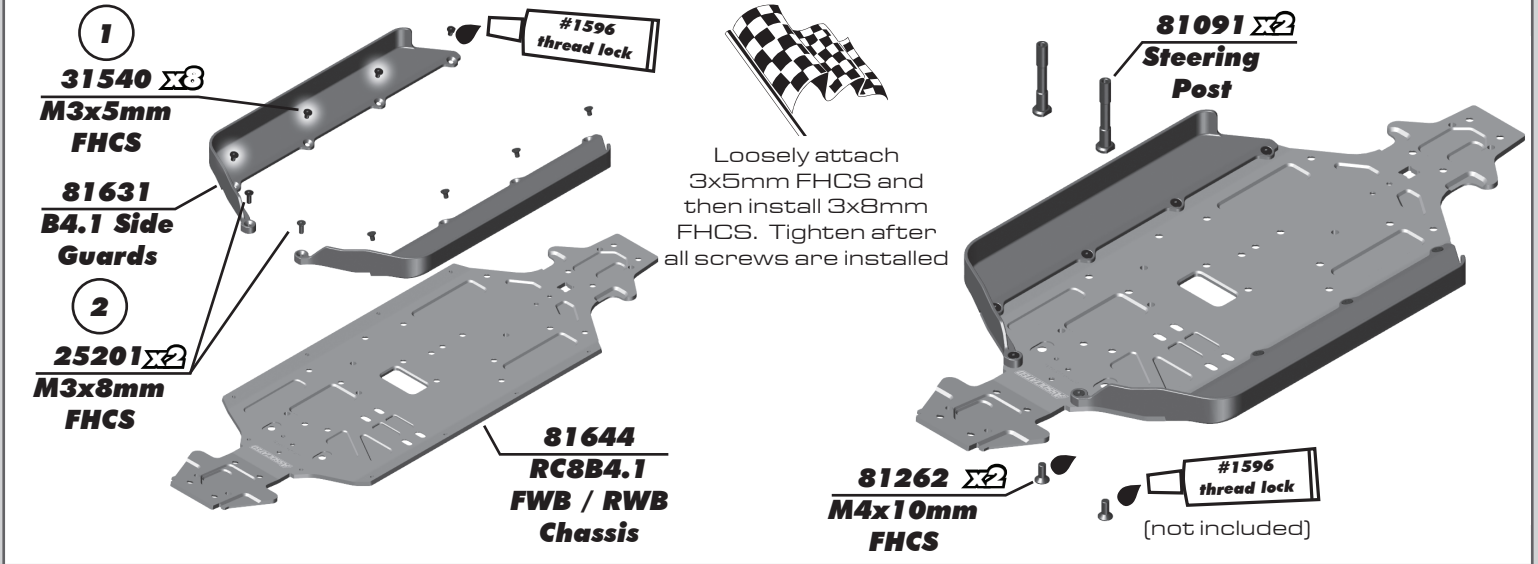

**:: Steering / Chassis Build - Bag 4.1 - Step 2**

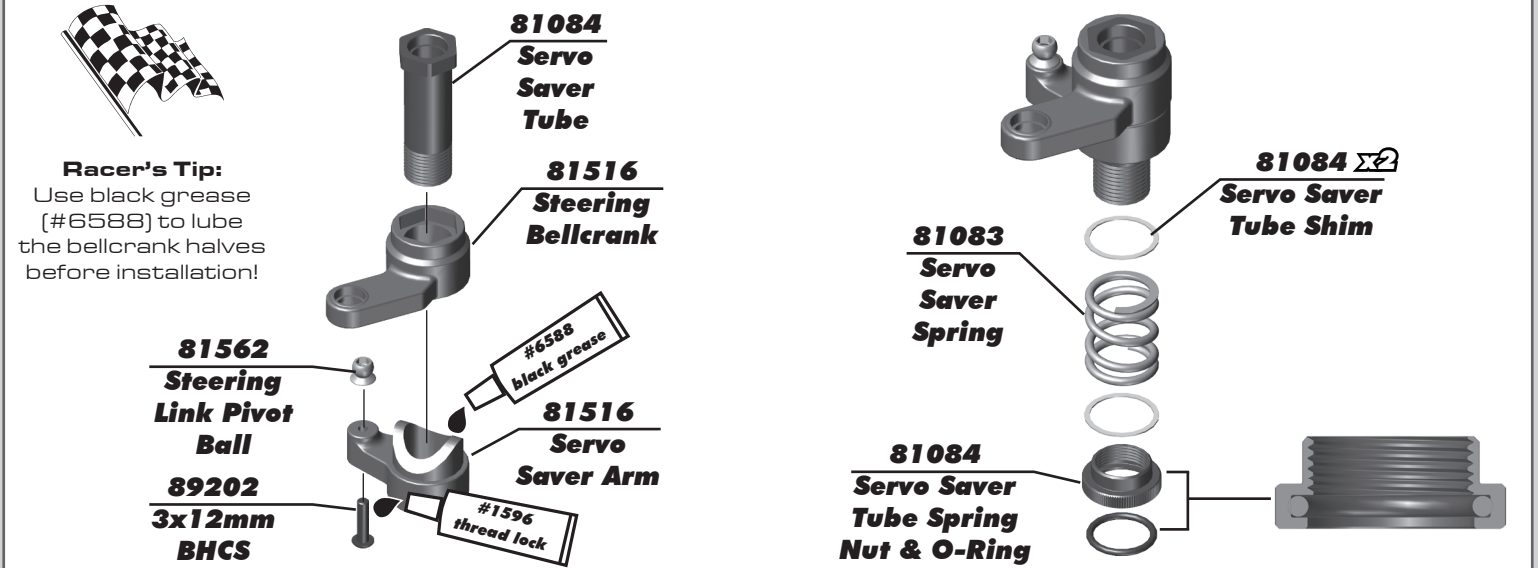

**:: Steering / Chassis Build - Bag 4.1 - Step 3**

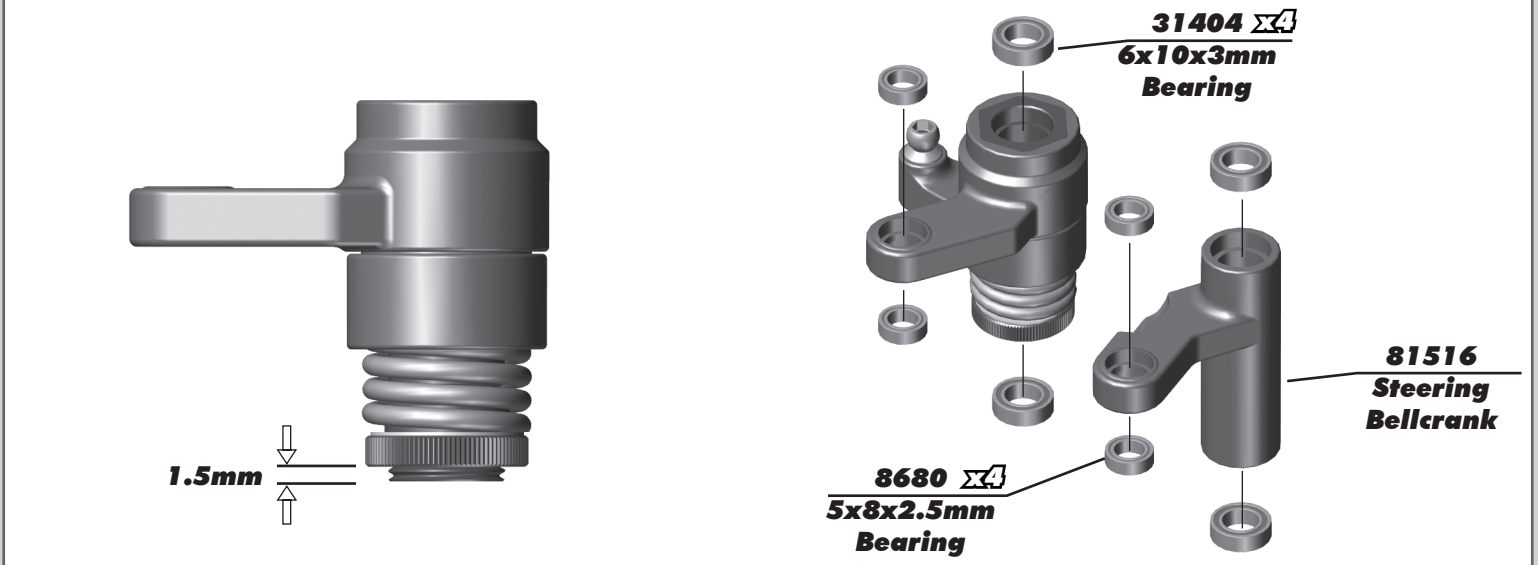

**:: Steering / Chassis Build - Bag 4.1 - Step 4**

**25201**  $\times 2$   
**3x8mm FHCS**

**#1596 thread lock**

**81518 Steering Rack**

**81517**  $\times 2$   
**Steering Bellcrank Nut**

**3mm hex wrench fits bellcrank nut hex.**

**:: Front Gearbox Build - Bag 5.1, 5.2, 5.3 - Step 1**

**Pinion Height Insert:**  
Dot at bottom = 0  
No dot = +1  
Dot at top = +2

**81689**  
**B4.2 Pinion Height Insert, Team Kit +1**

**4675**  $\times 2$   
**M2.5x6mm FHCS**

**91561**  $\times 2$   
**6x12x4mm Bearing**

**#6588 black grease**

**81468**  
**Diff Pinion Gear, 44/13 set**

**81687**  
**Dust Cap**

**4675**  
**2.5x6mm FHCS**

**81687**  
**B4.2 Gearbox, (Inboard)**

**81687**  $\times 2$   
**B4.2 Gearbox Flange Insert, Middle**

**#1596 thread lock**

**89221**  
**5x4mm Set Screw**

**81564**  
**Dogbone Outdrive, Front**

**Racer's Tip:**  
Clearance here for easier diff installation.

**Racer's Tip:**  
De-grease and clean set screw and cup for best thread lock.

**:: Front Gearbox Build - Bag 5.1, 5.2, 5.3 - Step 2**

**81689**  $\times 2$   
**B4.2 Gearbox Diff Height Insert, Team Kit 0**

**81381**  
**Diff Shim 13.5x15.8x0.20mm**

**25620**  $\times 2$   
**M3x10mm SHCS**

**81687**  
**Anti-Roll Bar Cap**

**81687**  
**B4.2 Gearbox, (Outboard)**

**#6588 black grease**

**STEP 1**

**STEP 2**

**Step 1:**  
Add shims on the ring gear side to TIGHTEN gear mesh. Subtract shims on this side to LOOSEN gear mesh.  
NOTE:  
Start 1x Thick 0.2mm

**Step 2:**  
Add or subtract shims here to finalize diff side to side play once gear mesh is set from Step 1.  
Recommended diff "side-to-side" clearance (gearbox assembly) 0.10 - 0.25mm. Start with 1 x 0.1mm.

**Note:**  
0.1 mm shim can be used for fine tuning of gear mesh

**:: Front Gearbox Build - Bag 5.1, 5.2, 5.3 - Step 3**

**Kit Setup:  
Arm Mount B**

**Kit Setup:  
Arm Mount A**

**Drop Screw:  
Kit Setup:  
1.5mm**

**Build left and right side!**

**81520**

**Arm Mount Insert, Down**

**81566**

**Arm Mount A**

**81446**

**Suspension Arm Shim**

**81567**

**Arm Mount B**

**81260**

**M4x14mm BHCS**

**81260**

**M4x14mm BHCS**

**81520**

**Arm Mount Insert, Center**

**81641**

**B4.1 Hinge Pin, 66.3mm**

**89317**

**Drop Screw**

**81636**

**Front Lower Arm, Soft**

**:: Front Gearbox Build - Bag 5.1, 5.2, 5.3 - Step 4**

**81512**

**Anti-Roll Bar Link**

**81585**

**Anti-Roll Bar Pivot**

**81585**

**Rod End Ball**

**89203**

**M3x16mm BHCS**

Note direction

**:: Front Gearbox Build - Bag 5.1, 5.2, 5.3 - Step 5**

**81129**

**(Front) Anti-Roll Bar, 2.2mm**

**81585**

**Anti-Roll Bar Collet**

**25225**

**3x3mm Set Screw**

Center the anti-roll bar collet on the anti-roll bar; then tighten the 3x3mm set screw.

Note direction

Front anti-roll bar gap: 2.0mm

Center!

**:: Front Gearbox Build - Bag 5.1, 5.2, 5.3 - Step 6**



Tighten 3x6mm set screws just enough to still allow the anti-roll bar to move freely.

**31521**  $\Sigma 2$   
**M2.5x8mm**  
**BHCS**

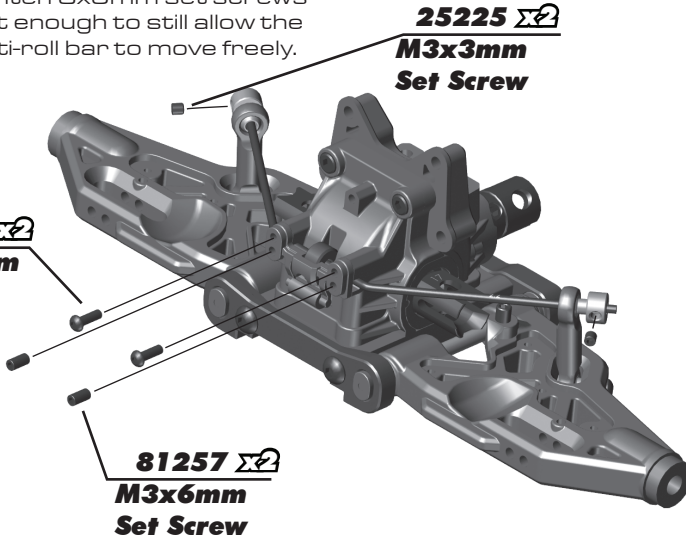

**25225**  $\Sigma 2$   
**M3x3mm**  
**Set Screw**

**81257**  $\Sigma 2$   
**M3x6mm**  
**Set Screw**

**89214**  
**4x12mm**  
**FHCS**

**89216**  
**M4**  
**Locknut**

**81524**  
**Body Post,**  
**Front**

**81576**  
**RC8B4e**  
**Top Plate**

**31532**  
**3x8mm**  
**BHCS**

**81525**  
**Chassis**  
**Brace,**  
**Front**

**:: Front Gearbox Build - Bag 5.1, 5.2, 5.3 - Step 7**

**Kit Setup:**



**31541**  $\Sigma 2$   
**3x6mm**  
**FHCS**

**#1596**  
**thread lock**

**81520**  $\Sigma 2$   
**Arm Mount**  
**Insert,**  
**Center**

**81647**  
**B4.1 Upper**  
**Link Mount,**  
**Angled**

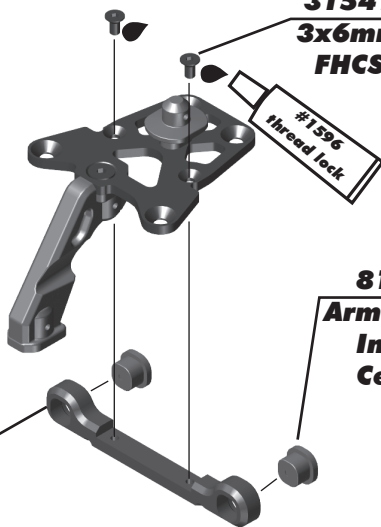

**89214**  $\Sigma 2$   
**4X12mm**  
**FHCS**

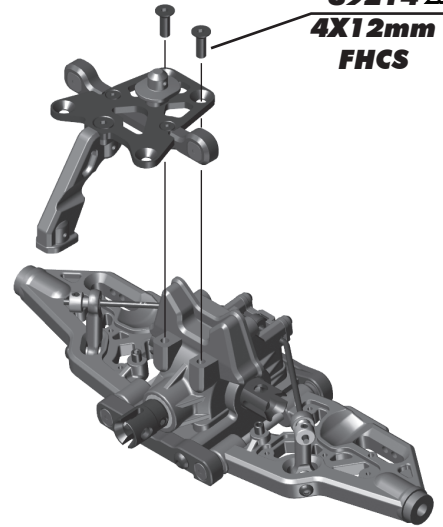

**:: Front Gearbox Build - Bag 5.1, 5.2, 5.3 - Step 8**

**Kit Setup:**



**89226**  $\Sigma 2$   
**M3x26mm**  
**SHCS**

**#1596**  
**thread lock**

**!**  
Install arm  
mount  
inserts in  
direction shown!

**81520**  $\Sigma 2$   
**Arm Mount**  
**Insert,**  
**Side**

**81591**  $\Sigma 2$   
**FT Shock**  
**Bushing,**  
**14mm**

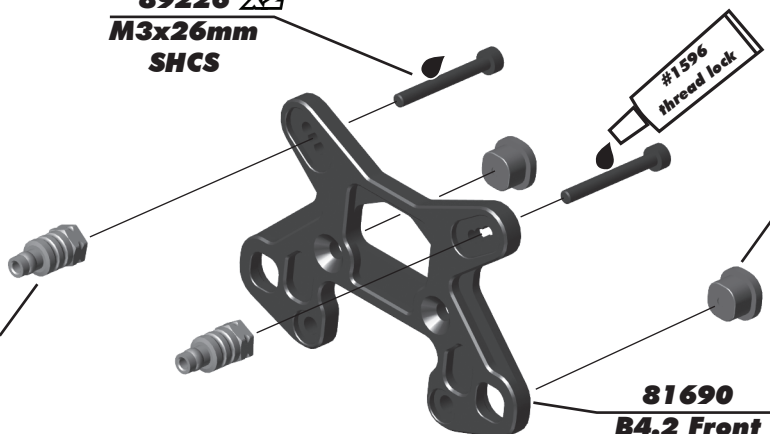

**81690**  
**B4.2 Front**  
**Shock Tower,**  
**8deg KPI**

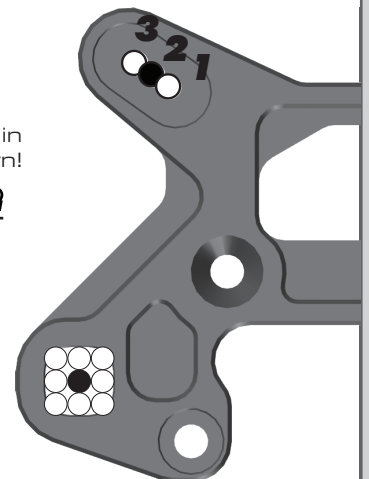

**:: Front Gearbox Build - Bag 5.1, 5.2, 5.3 - Step 9**

**Build left and right side!**

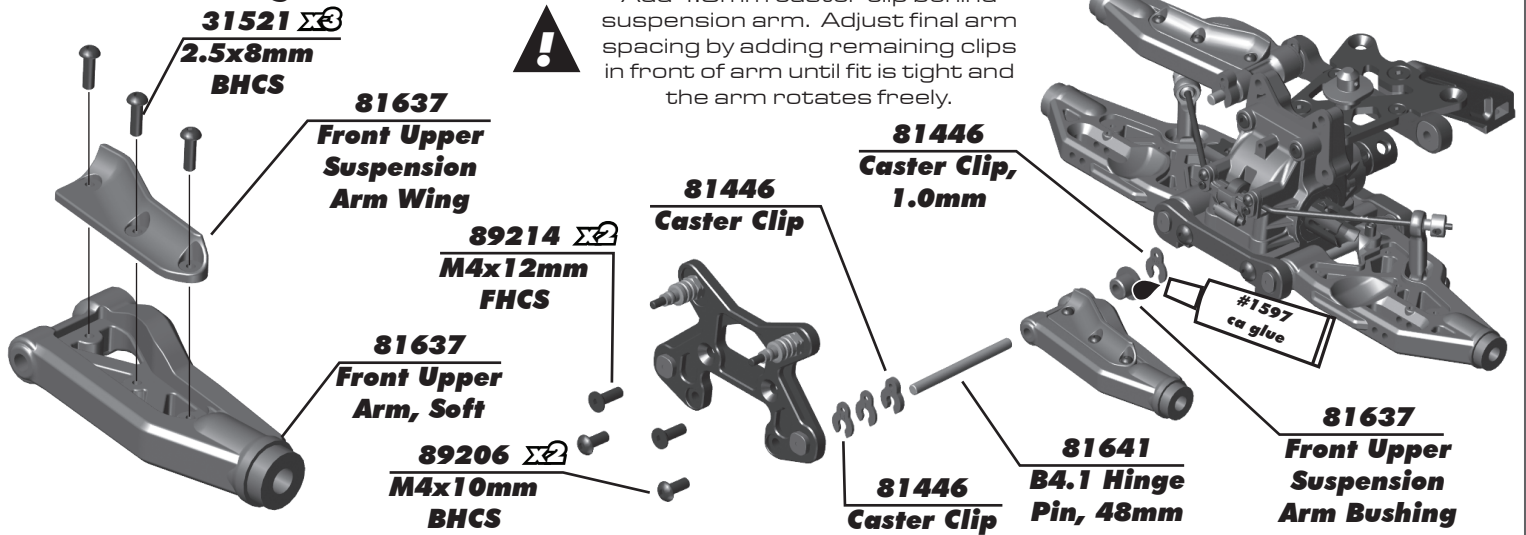

**:: Steering Blocks Build - Bag 6.1 - Step 1**

**Build left and right side!**

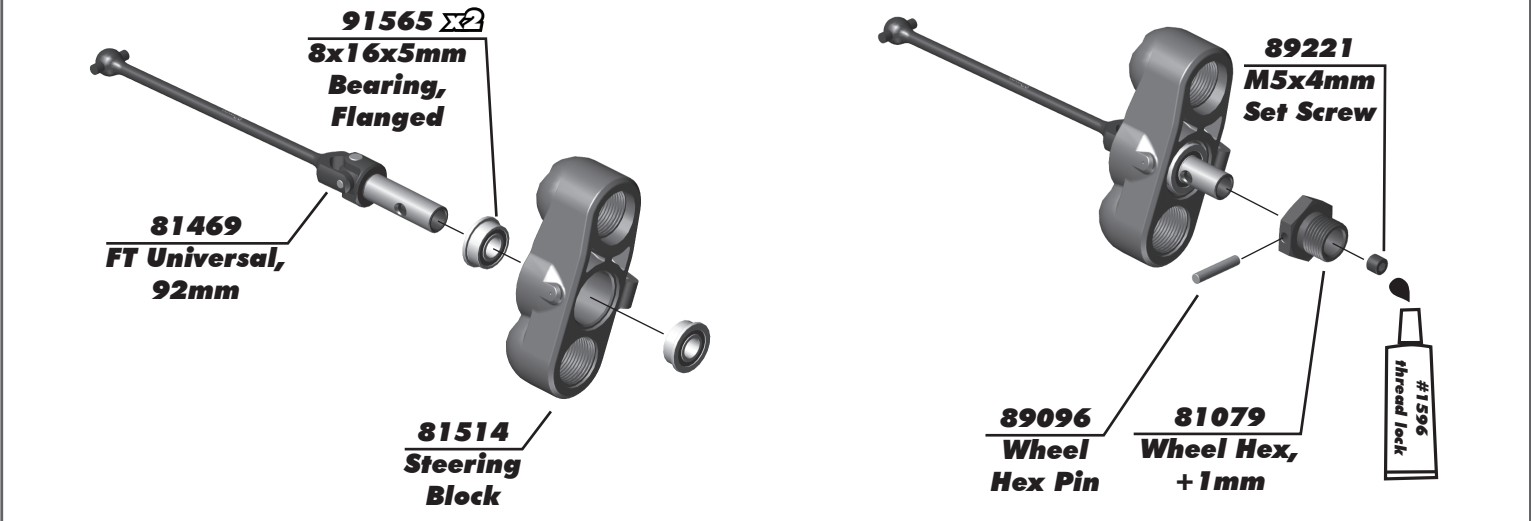

**:: Steering Blocks Build - Bag 6.1 - Step 2**

**Build left and right side!**

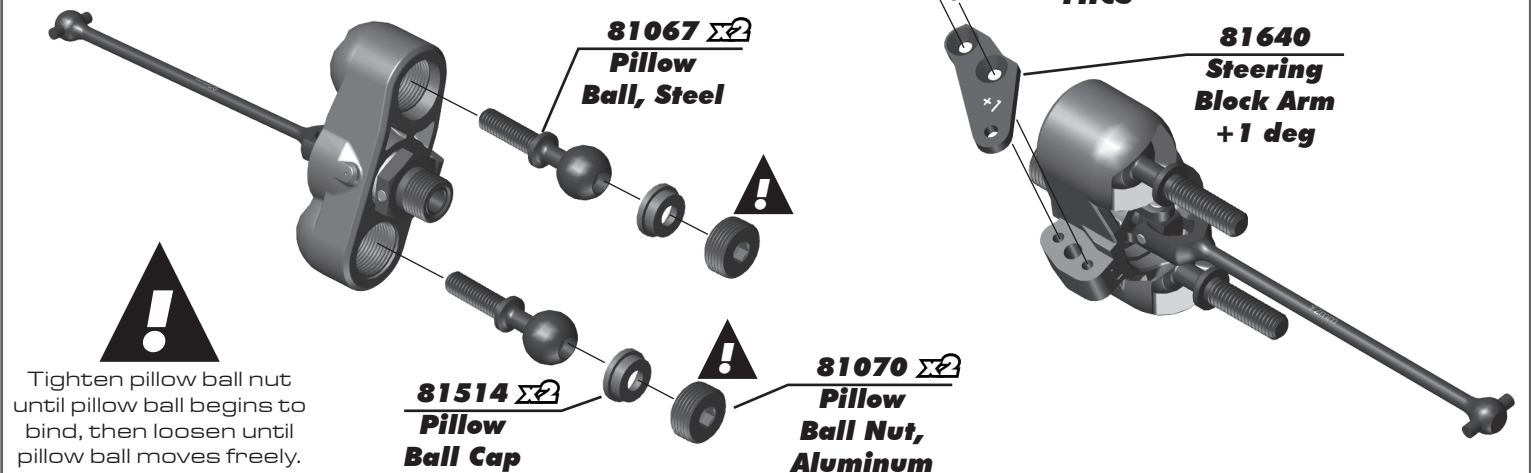

**:: Steering Blocks Build - Bag 6.1 - Step 3**

**81056** X2  
Suspension Arm Endcap

**81072**  
Pillow Ball Shim (1.4mm)

**81072**  
Pillow Ball Shim (0.7mm)

**31385**  
Bulkhead Washer, 7.8x3.0x1mm Blue Aluminum

**25620**  
M3x10mm SHCS

**#1596**  
Thread Lock

**Pillow Ball Shims**

0.35mm 0.7mm 1.4mm

**:: Steering Blocks Build - Bag 6.1 - Step 4**

**81262** X2  
M4x10mm FHCS

**#1596**  
thread lock

**31532** X2  
M3x8mm BHCS

**81643**  
B4.1 Front Bumper

**31386** X2  
Bulkhead Washer, 7.8x3.0x2mm Blue Aluminum

**89216**  
M4 Locknut

**89214**  
M4x12mm FHCS

**81264** X2  
M4x20mm FHCS

**89217** X2  
M4x14mm FHCS

For attaching steering link to steering rack

**Kit Setup:**

**:: Steering Blocks Build - Bag 6.1 - Step 5**

**Kit Setup:**  
Mount the front shock in the outside hole on the front arm.

**25612**  
M3 Locknut W/ Flange

**81509**  
Shock Pin

**81257**  
M3x6mm Set Screw

**:: Rear End Build - Bag 7.1, 7.2, 7.3 - Step 1**

**Pinion Height Insert:**  
 Dot at bottom = 0  
 No dot = +1  
 Dot at top = +2

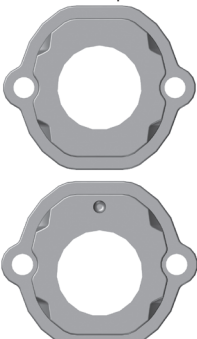

**81689**  
**B4.2 Pinion Height Insert, Team Kit 0**

**Racer's Tip:**  
 Clearance here for easier diff installation.

**4675**  $\Sigma 2$   
**M2.5x6mm FHCS**

**#6588**  
**black grease**

**81468**  
**Diff Pinion Gear, 44/13 set**

**81688**  
**Dust Cap**

**4675**  
**M2.5x6mm FHCS**

**81688**  
**B4.2 Gearbox, (Inboard)**

**81688**  $\Sigma 2$   
**B4.2 Gearbox Flange Insert, Low**

**81565**  
**Dogbone Outdrive, Rear**

**#1596**  
**thread lock**

**89221**  
**M5x4mm Set Screw**

**91561**  $\Sigma 2$   
**6x12x4mm Bearing**

**Racer's Tip:**  
 De-grease and clean set screw and cup for best thread lock.

**:: Rear End Build - Bag 7.1, 7.2, 7.3 - Step 2**

**81689**  $\Sigma 2$   
**B4.2 Gearbox Diff Height Insert, Team Kit 0**

**81381**  
**Diff Shim 13.5x15.8x0.20mm**

**81688**  $\Sigma 2$   
**Anti-Roll Bar Cap**

**25620**  $\Sigma 2$   
**M3x10mm SHCS**

**81688**  
**B4.2 Gearbox, (Outboard)**

**#6588**  
**black grease**

**STEP 1**

**STEP 2**

**Step 1:**  
 Add shims on the ring gear side to TIGHTEN gear mesh. Subtract shims on this side to LOOSEN gear mesh.  
 NOTE:  
 Start 1x Thick 0.2mm

**Step 2:**  
 Add or subtract shims here to finalize diff side to side play once gear mesh is set from Step 1. Recommended diff "side-to-side" clearance (gearbox assembly) 0.10 - 0.25mm. Start with 1 x 0.1mm.

**Note:**  
 0.1mm shim can be used for fine tuning of gear mesh

**:: Rear End Build - Bag 7.1, 7.2, 7.3 - Step 3**

**Kit Setup:**

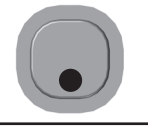

**81454**  
**Arm Mount, HRC, Narrow (C)**

**81260**  $\Sigma 2$   
**M4x14mm BHCS**

**81520**  $\Sigma 2$   
**Arm Mount Insert, Center**

**:: Rear End Build - Bag 7.1, 7.2, 7.3 - Step 4**

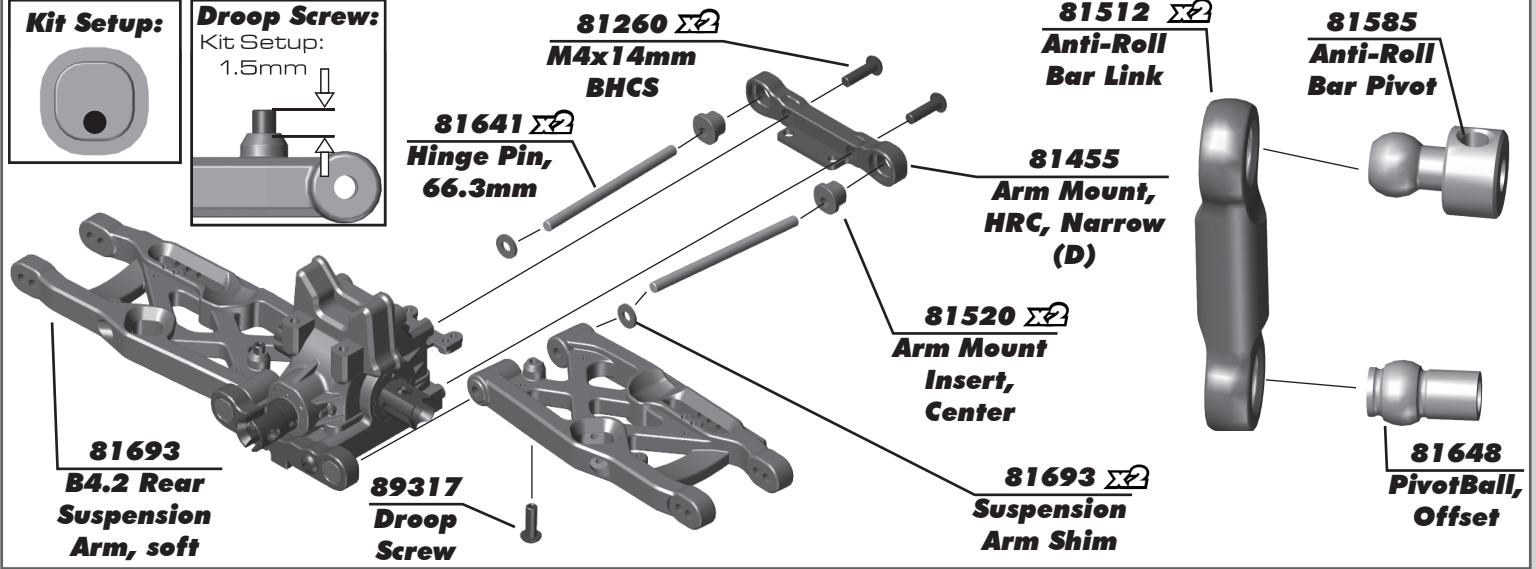

**:: Rear End Build - Bag 7.1, 7.2, 7.3 - Step 5**

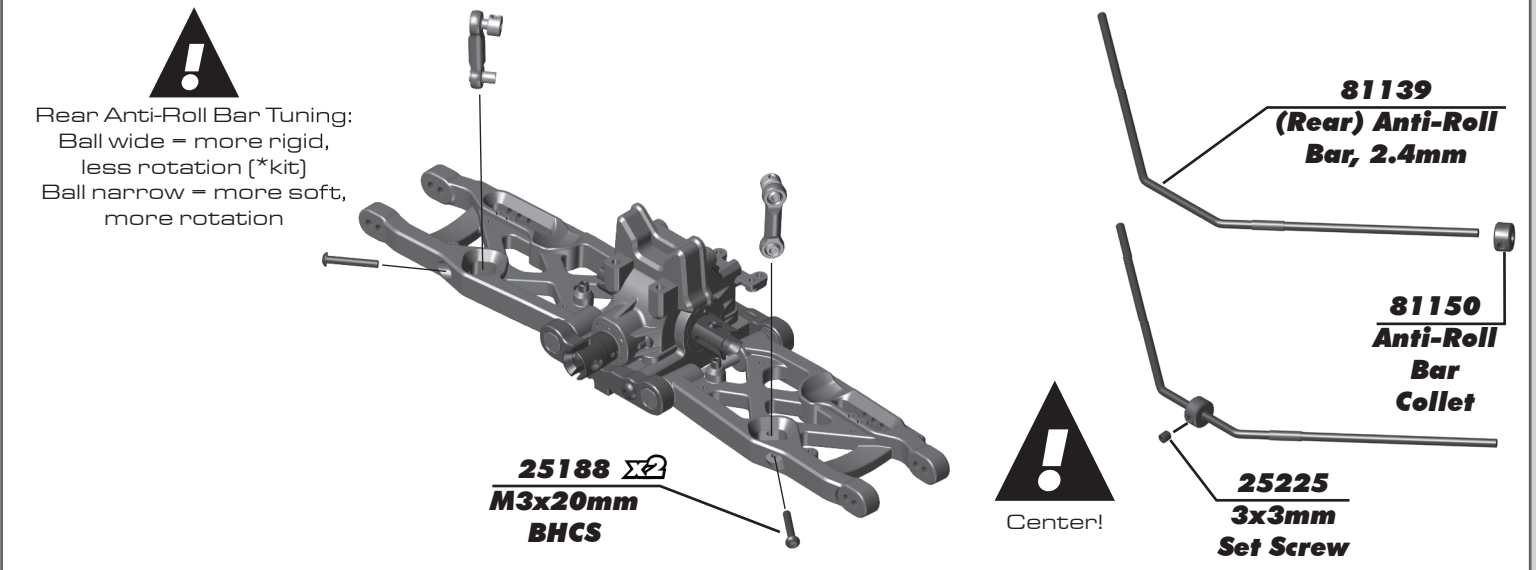

**:: Rear End Build - Bag 7.1, 7.2, 7.3 - Step 6**

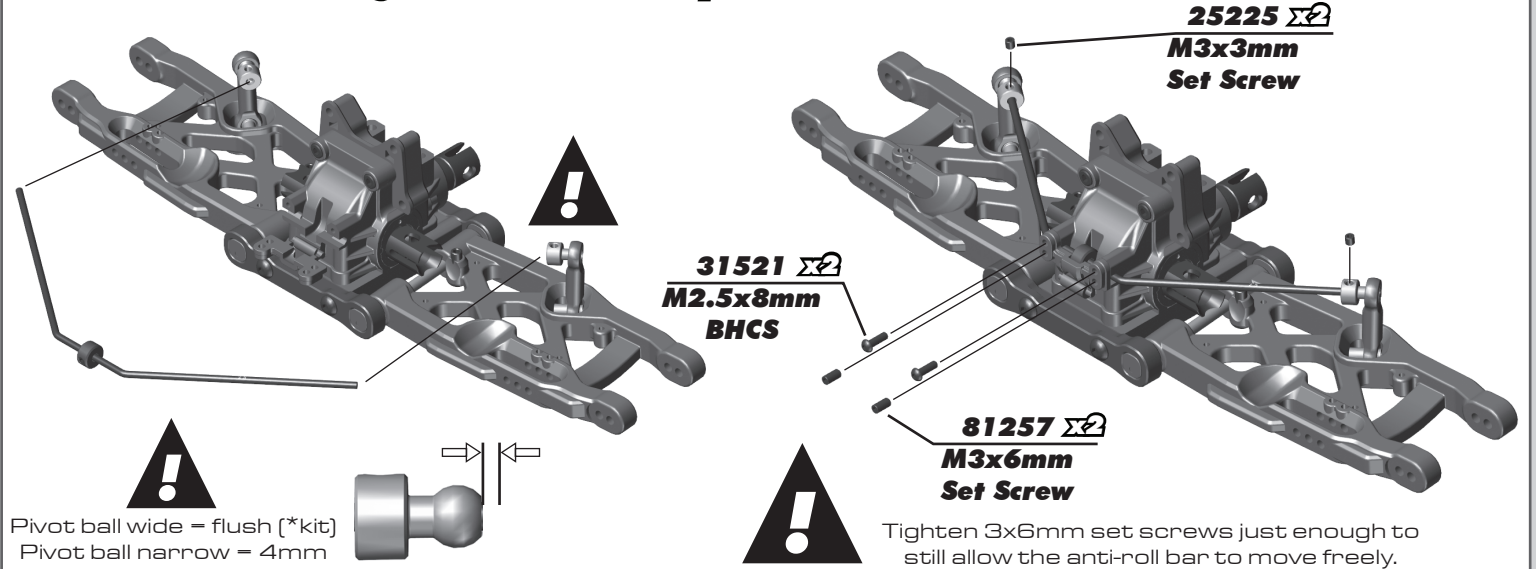

**:: Rear End Build - Bag 7.1, 7.2, 7.3 - Step 7**

**Racer's Tip:**  
Tune the rear end for more flex with #81562 ball end insert here

**81525 Chassis Brace, Rear**

**25189 3x22mm BHCS**

**81525 Chassis Brace Mount**

**81525 Rear Chassis Brace Insert**

**25612 M3 Locknut W/Flange**

**89214 M4x12mm FHCS**

**31532 3x8mm BHCS**

**81525 Chassis Brace Insert**

Check label on chassis brace in this area.

**:: Rear End Build - Bag 7.1, 7.2, 7.3 - Step 8**

**Kit Setup:**

**81591 FT Shock Bushing, 17mm**

**89208 M3x14mm FHCS**

**CHOOSE ONE**  
Fin adds straight-line stabilization. Button adds agility in corners.

**81553 Wing Buttons**

**81700 High Downforce Wing, Black**

**81692 B4.2 Rear Shock Tower**

**81552 Wing Angle Shim, -2**

**81552 Wing Mount**

**25215 M3 Locknut**

**89227 M3x28mm SHCS**

**41090 M3x10mm LP SHCS**

**81524 Body Post, Rear**

**81558 Body Post Grommet**

**81524 Body Post Mount, Rear**

#1596 thread lock

**:: Rear End Build - Bag 7.1, 7.2, 7.3 - Step 9**

Refer to previous step [8] for wing height position

**89454 M3x12mm SHCS**

**81552 Wing Mount Adapter**

**25215 M3 Locknut**

**89214 M4x12mm FHCS**

**89206 M4x10mm BHCS**

**:: Rear Hubs Build - Bag 8.1, 8.2 - Step 1**

**Build two!**

**81469 B3 FT Universals, 92mm**

**81649 B4.1 Rear Hub Plates (standard)**

**25188 M3x20mm BHCS**

**25215 M3 Locknut**

**81695 B4.2 Rear Hubs, Offset**

**91564 8x16x5mm Bearing**

**81257 3x6mm Set Screw**

**81079 Wheel Hex, +1mm Wide**

**89096 Wheel Hex Pin**

**89221 5x4mm Set Screw**

**Racer's Tip:** Use a 2mm drill to punch thru the thin wall between set screws and the hinge pin. Tighten after installation to remove slop.

**Warning:** Tighten set screw before camber link installation.

**:: Rear Hubs Build - Bag 8.1, 8.2 - Step 2**

**Install left and right side!**

**81076 Hub Hinge Pin**

**81695 B4.2 Rear Hub Shim, 1mm**

**25612 M3 Locknut w/Flange**

**25192 M3x20mm SHCS**

**25620 M3x10mm SHCS**

**Kit Setup:** B4.2 offset hubs use short arm hole.

**Kit Setup:** (Diagram of a component with a hole)

**:: Rear Hubs Build - Bag 8.1, 8.2 - Step 3**

**Tuning Tip:** Remove screw A for "soft/short" flex configuration.

**A B** (Diagram of a component with two holes)

**Kit Setup:** Mount the rear shock in the outside hole on the rear arm.

**ABC** (Diagram of a component with three holes)

**89216 M4 Locknut**

**81264 M4x20mm FHCS**

**89214 M4x12mm FHCS**

**89217 M4x14mm FHCS**

**25612 M3 Locknut W/ Flange**

**81509 Shock Pin**

**81257 M3x6mm Set Screw**

**:: Center Bulkhead - Bag 9.1 - Step 1**



Note: Do not use brake rotor guides on center bulkheads

**Motor Direction on ESC to Reverse**

Weight Bias Setting	<b>FWB</b>	<b>RWB</b>
Center Diff Adapter Position	FWD	RWD
Motor Clamp Position	FWD	RWD
Front Dogbone Shaft (mm)	96.5	104
Rear Dogbone Shaft (mm)	104	96.5

**89216**  $\Sigma 2$

**M4 Locknut**

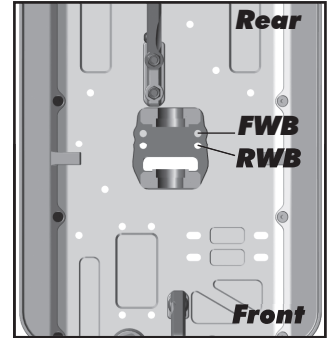

**81448**  $\Sigma 2$   
**Center Bulkhead, Lower**

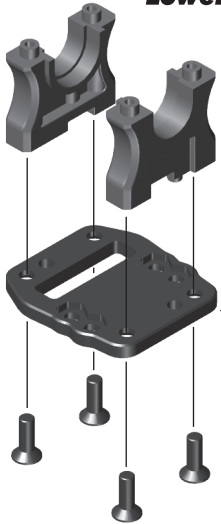

**81645**  
**FWB / RWB Adapter Plate**

**89214**  $\Sigma 4$   
**4x12mm FHCS**

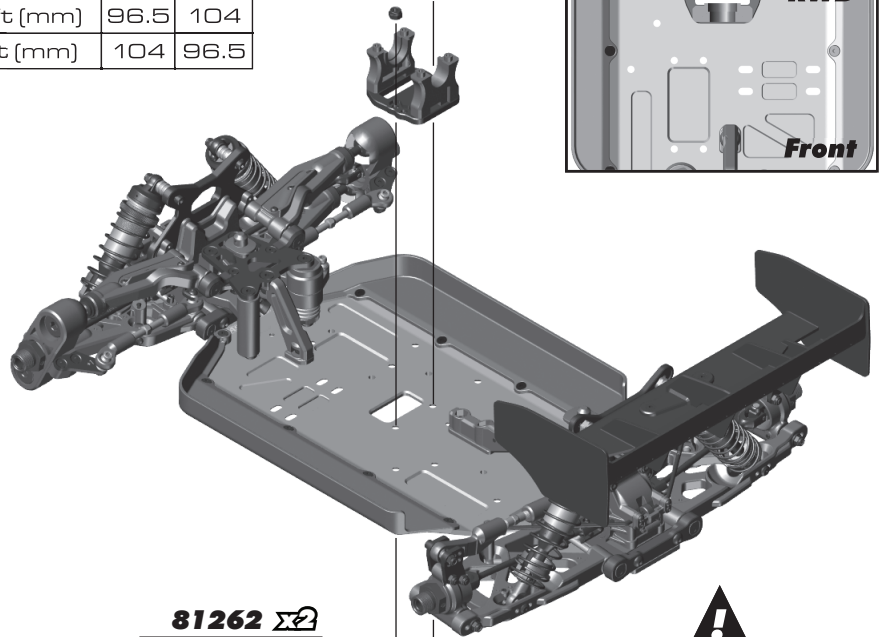

**81262**  $\Sigma 2$   
**4x10mm FHCS**



Note: The upper center bulkheads have "F" for front and "R" for rear.

**:: Center Bulkhead - Bag 9.1 - Step 2**

**89212**  $\Sigma 4$   
**3x30mm FHCS**

**81581**  
**RC8B4e Center Dogbone, 104mm**

**81578**  
**RC8B4e Front Top Plate**

**81448**  $\Sigma 2$   
**Center Bulkhead, Upper**

**81646**  
**RC8B4e Center Dogbone, 96.5mm**

**31521**  $\Sigma 2$   
**2.5x8mm BHCS**

**81572**  
**RC8B4e Wire Routing Clips**

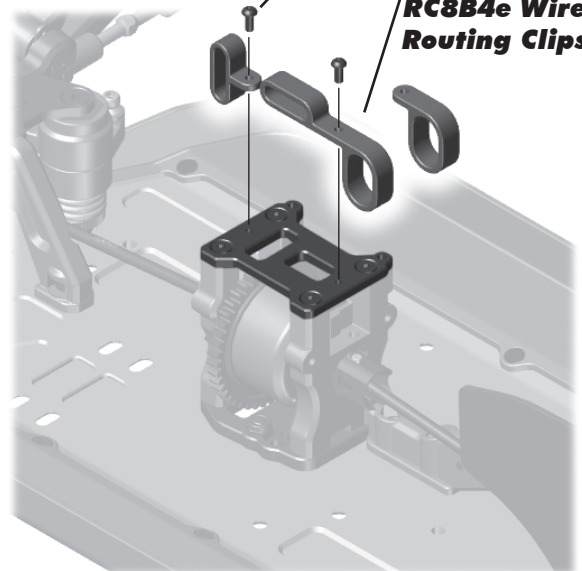
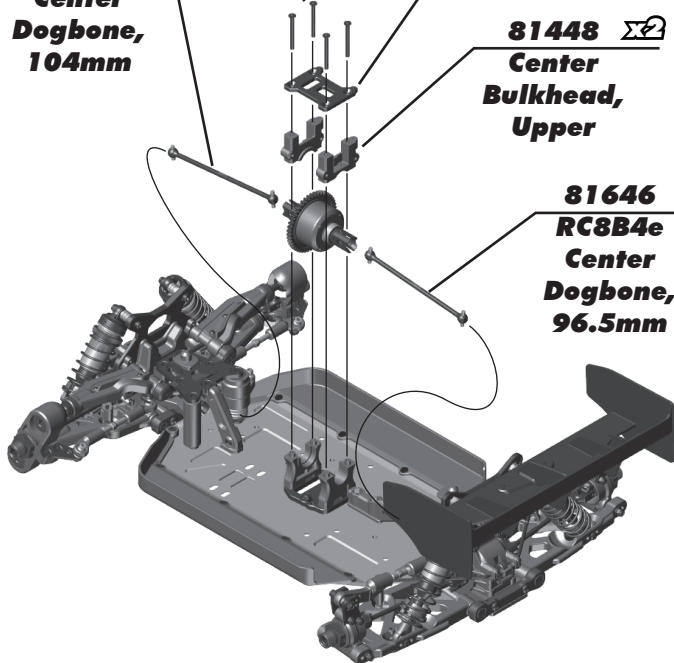

**:: Center Bulkhead - Bag 9.1 - Step 3**

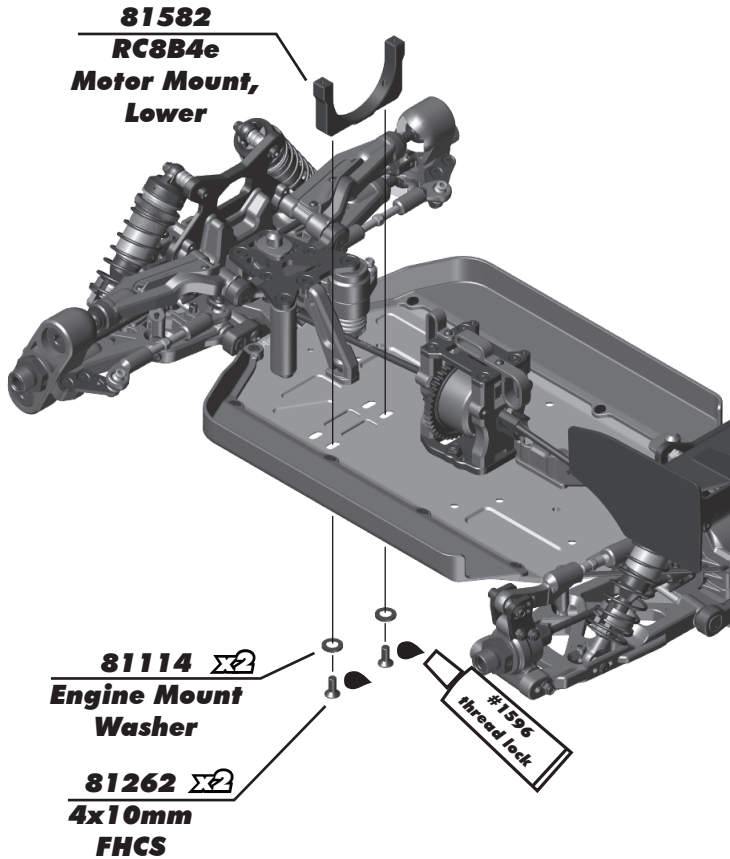

Optional!  
30mm fan  
(not included)

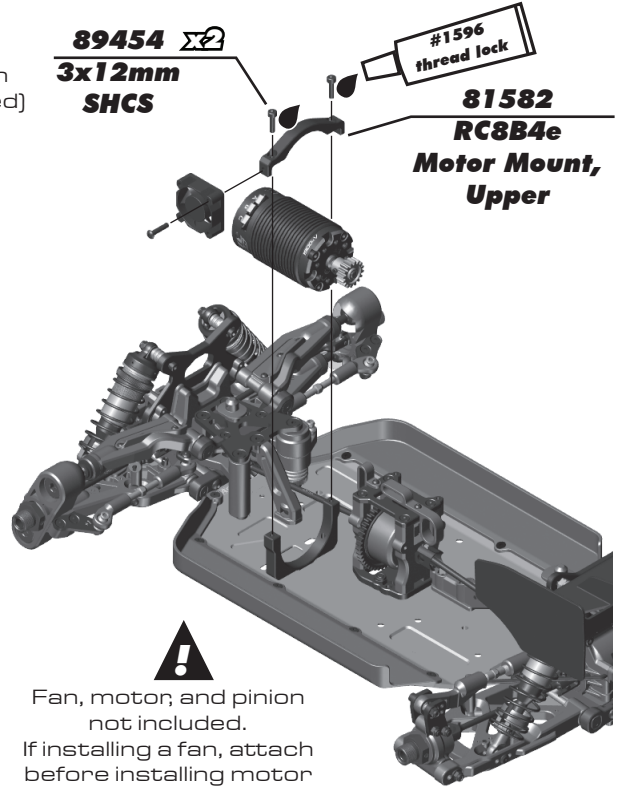

**!**  
Fan, motor, and pinion not included.  
If installing a fan, attach before installing motor mounts.  
Hardware not included.  
Maximum screw depth 4mm.

**:: Radio Tray Build - Bag 10.1, 11.1 - Step 1**

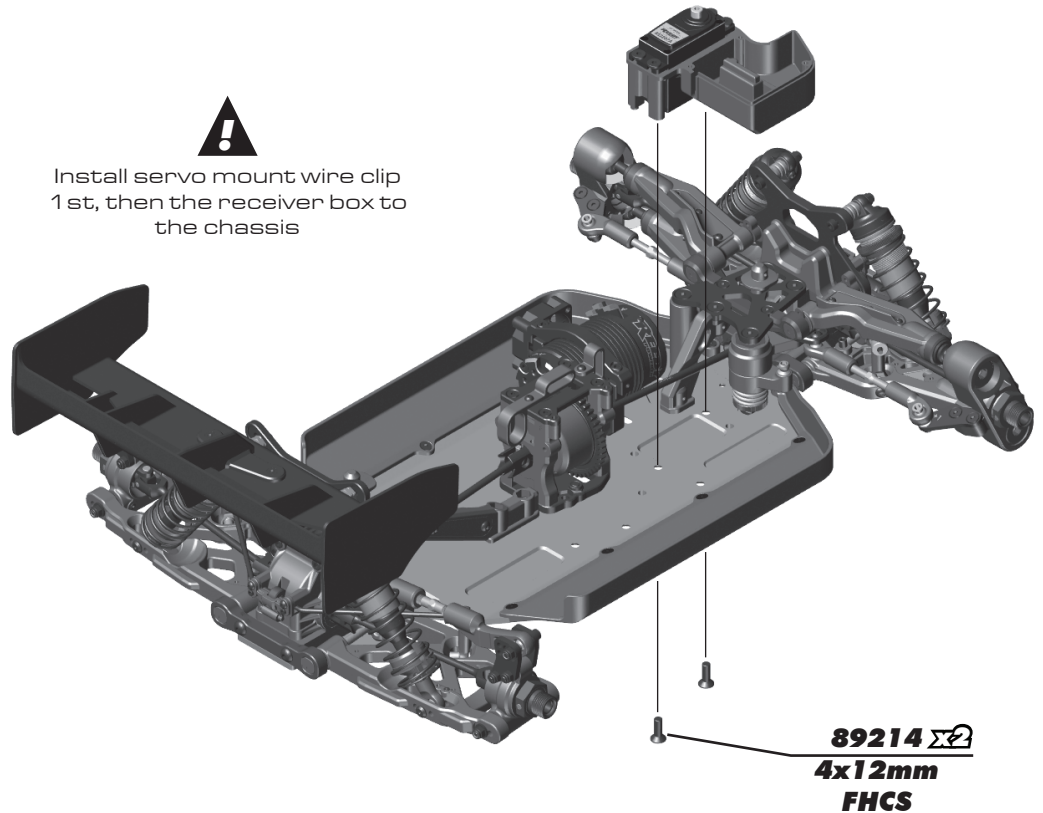
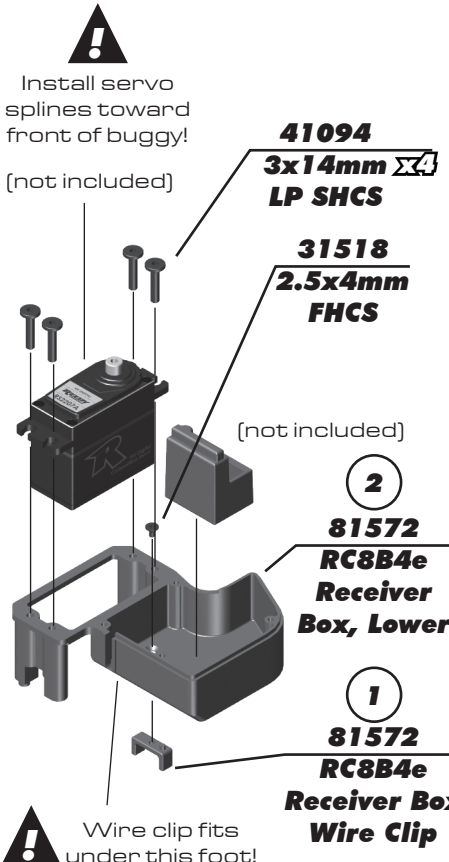

**:: Radio Tray Build - Bag 11.1 - Step 2**

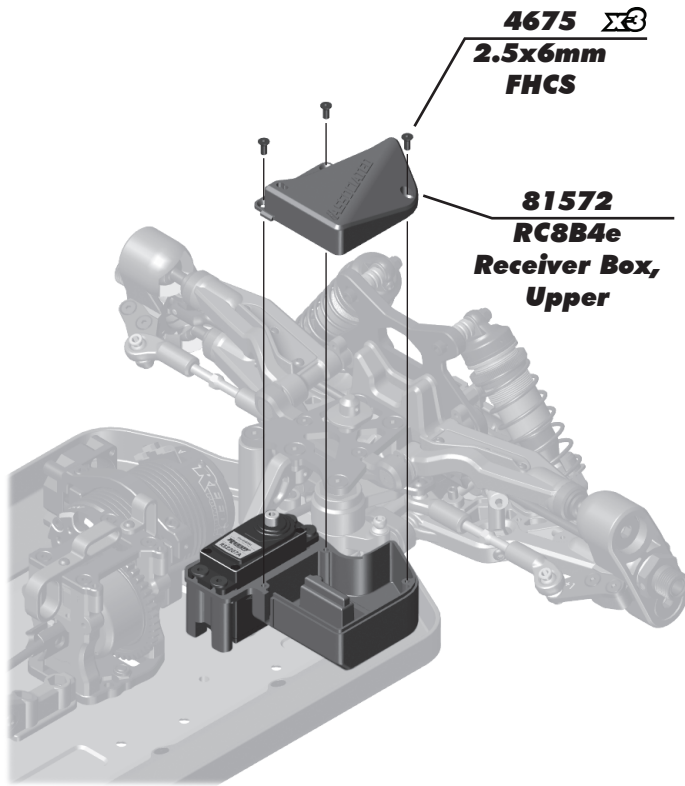

**4675**  $\Sigma 3$   
**2.5x6mm**  
**FHCS**

**81572**  
**RC8B4e**  
**Receiver Box,**  
**Upper**

**Spline Count**



Printed here  
**23T**  
**25T**

**81556**  
**Servo Horn**  
**(Steering)**

**25215**  
**M3**  
**Locknut**

**81556**  
**Servo Horn**  
**Insert**

**91048**  
**HD Ball**  
**Stud, 8mm**

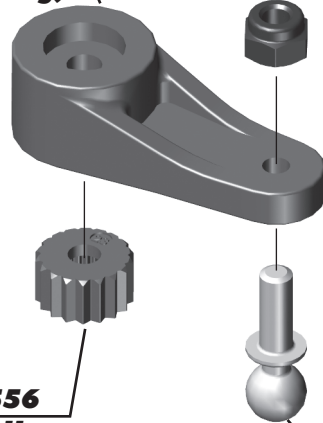

**:: Radio Tray Build - Bag 11.1 - Step 3**

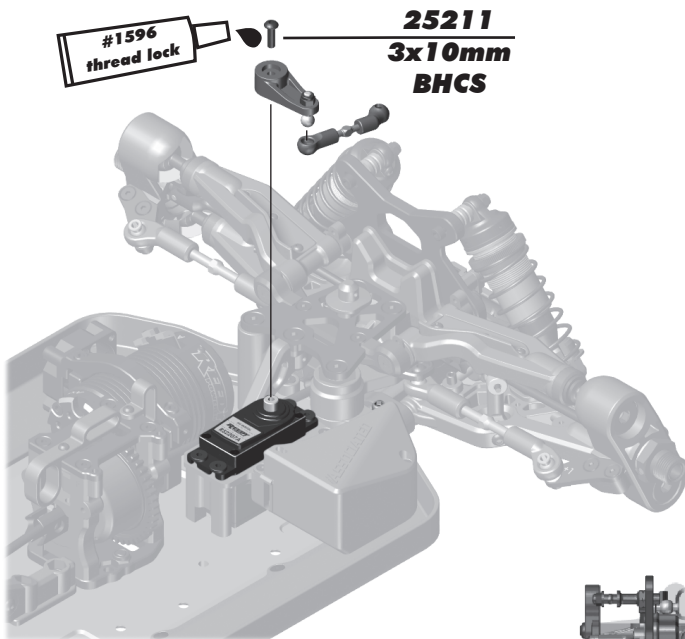

**#1596**  
**thread lock**

**25211**  
**3x10mm**  
**BHCS**



To build RC8B4.2e for use with two 2s shorty battery packs in a "saddle" configuration, follow the steps below.

To build RC8B4.2e for use with one 4s shorty battery pack, continue to "Battery Tray Build - Bag 12.1 - Step 2"

**2s Shorty Pack Configuration**

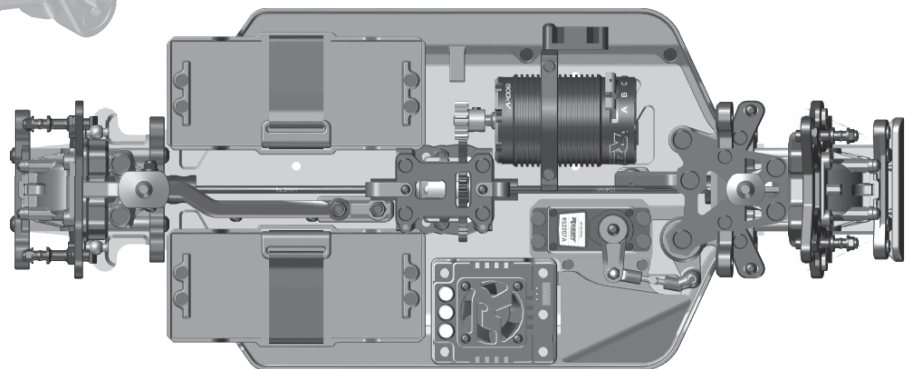

**:: Battery Tray Build - Bag 12.1 - Step 1**



!!!ALERT!!!

ESC Setup needs motor rotation = REV  
Reverse Motor Rotation only



Reverse ESC in program box

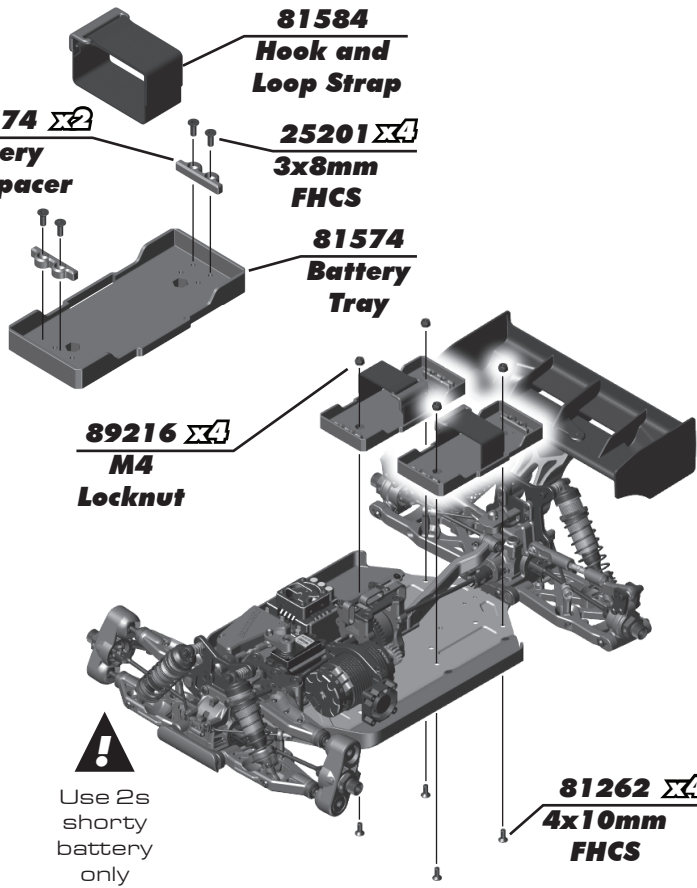
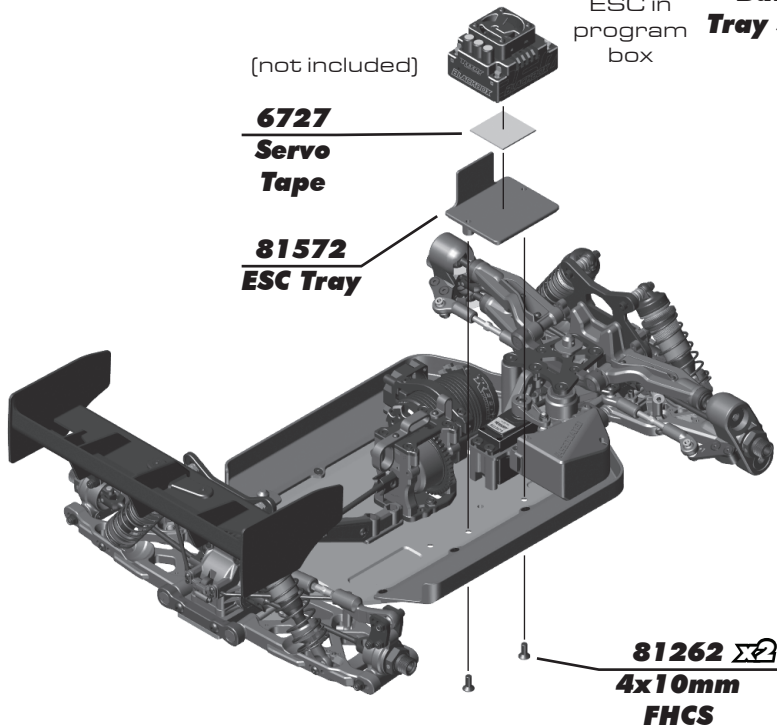

**:: Battery Tray Build - Bag 12.1 - Step 2**

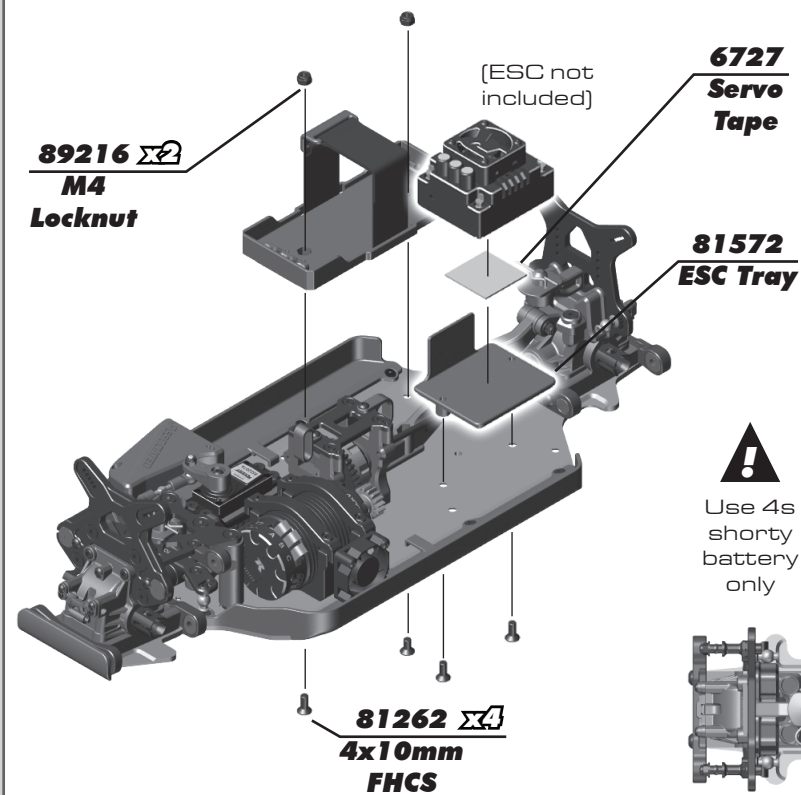

!! ALERT !!

4s Shorty pack configuration does not fit with the kit body (#81568).

Fits with optional brand bodies that clear the taller cell configuration.



Use 4s shorty battery only

**4s Shorty Pack Configuration**

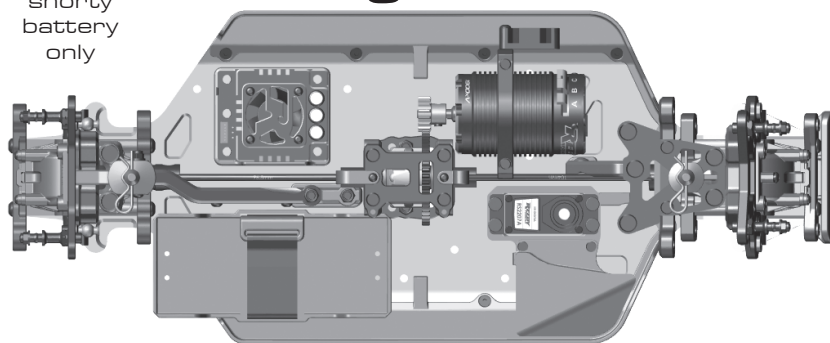

**:: Wheels / Tires / Body - Misc. - Step 2**



Install wheel nuts with the serrated edge towards the wheel.

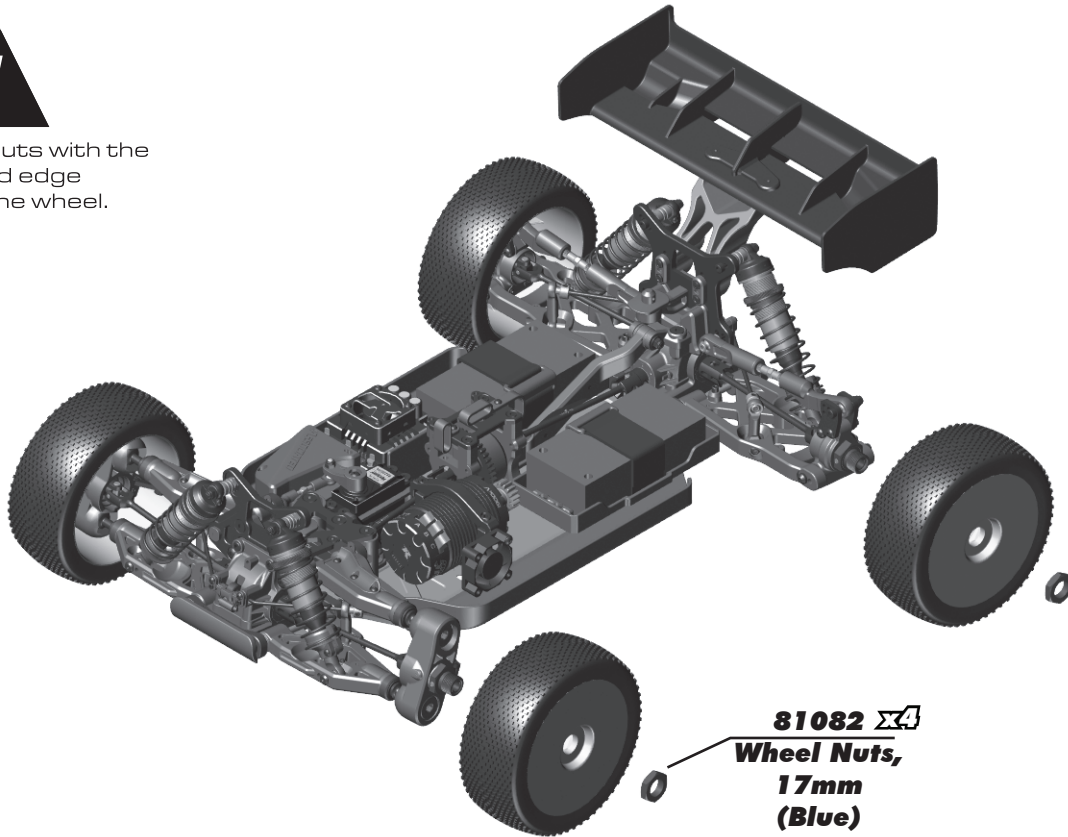

**81082**   
**Wheel Nuts,**  
**17mm**  
**(Blue)**

**:: Wheels / Tires / Body - Misc. - Step 3**



Final chassis ride height.  
 Front = 23mm  
 Rear = 26mm

**81568**  
**Body**

**2208**   
**Body Clip**

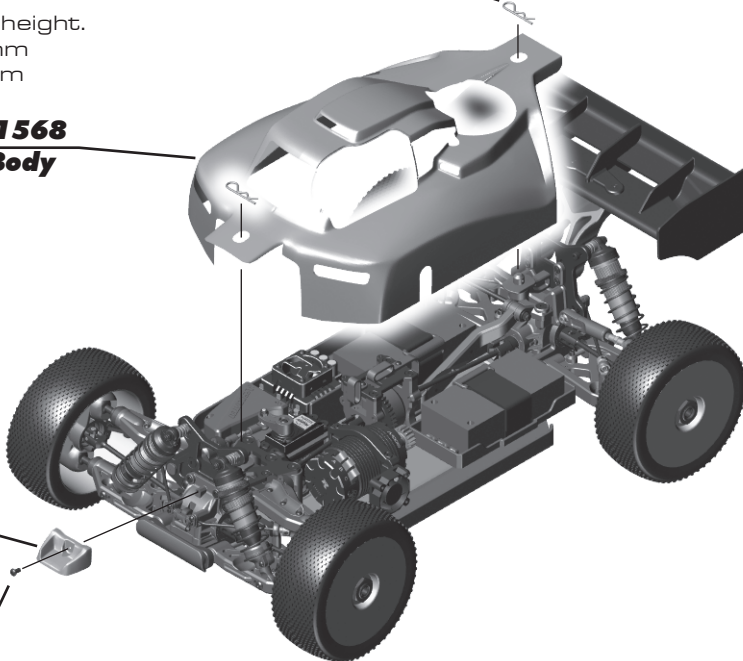

**81583**  
**Nose**  
**Cone**

**31531**  
**3x6mm**  
**BHCS**

**Painting Tips:**

Your kit comes with a clear polycarbonate body. You will need to prep the body before you can paint it. Wash the inside thoroughly with warm water and liquid detergent. Dry the body using a clean, soft, lint-free cloth. Install the window masks on the inside of the body. (R/C cars get painted from the inside). Using high quality masking tape, apply tape to the inside of the body to create a design. Spray (either rattle can or airbrush R/C specific paint) the paint to the inside of the body (preferably dark colors first, lighter colors last).

NOTE: use ONLY paint that is recommended for use with (polycarbonate) plastics. If you do not, you can destroy the polycarbonate body!!!

After painting, cut the body along the trim lines. Make sure to drill or use a body reamer to make the holes for the body mounts and antenna!

## :: Droop Settings

Set droop by measuring overall length of shock (from standoff to shock pin) while the chassis is elevated above your working surface. The shocks should be fully extended.

Kit setup for front droop is 101mm shock length, and 126mm shock length for the rear using "C" hole.

If the shock length is too long, adjust by turning the droop screws clockwise.

If the shock length is too short, adjust by turning the droop screws counter-clockwise.

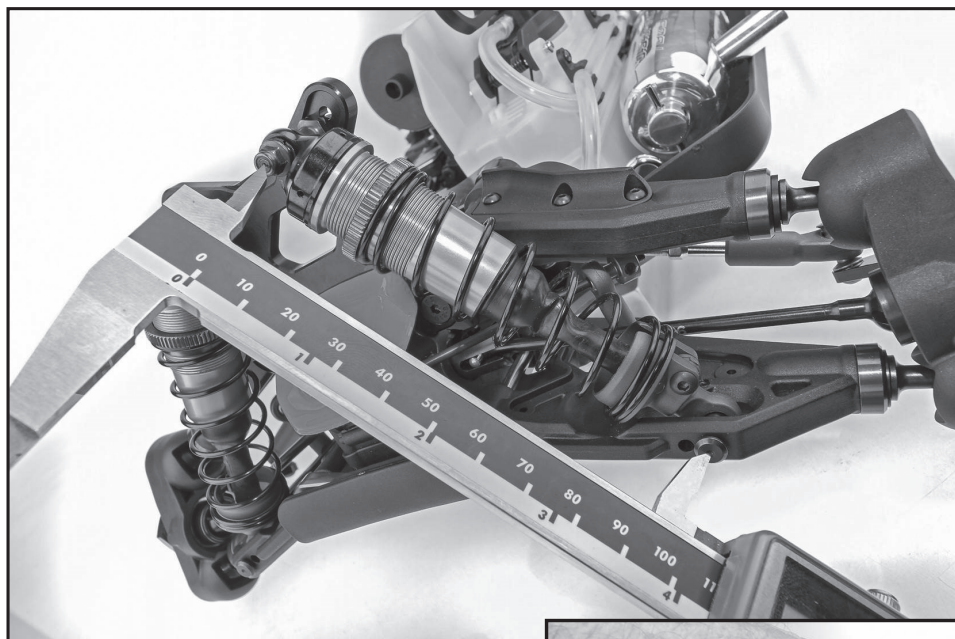

### Racer's Tip:

Use 123mm for the middle "B" rear arm hole, and +2 or 0 eyelet.

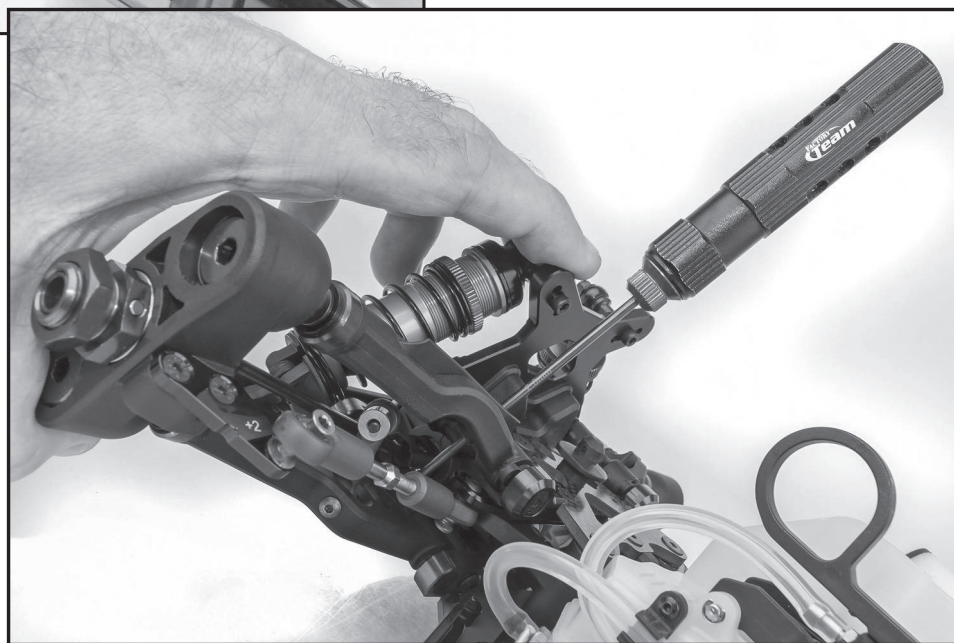

**Front Droop:** Increasing front droop (loosen droop screws) will increase off-throttle steering. It also allows the front end to lift more, giving more rear grip and less front grip on-power. Remember to never loosen the screws beyond the FULL DROOP setting. Decreasing front droop (tighten droop screws) yields more on-power steering and quicker response at the expense of some stability in bumpy sections. It will also give less off-throttle steering.

**Rear Droop:** Increasing rear droop (loosen droop screws) will increase traction in bumpy sections, but will reduce high-speed stability. Remember to never loosen the screws beyond the FULL DROOP setting. Decreasing rear droop (tighten droop screws) will increase stability in high speed sections, but will reduce stability in bumpy sections.

### Setup Sheets:

To find different setups for your kit, visit our website, <https://www.associatedelectrics.com/teamassociated/> and click on the "Setup Sheets" link, and then the link to your model. Our team of professional drivers help develop these setups at races worldwide. Additionally, most drivers have a "base" setup that they use as a starting point for most races. Try running some of our base setups or look for track conditions and tires that are similar to your local track and replicate that setup. Remember, each adjustment has a purpose, so copy everything from the setup sheet and then make adjustments based on the recommendations in here.



***Associated Electrics, Inc.***  
***21062 Bake Parkway Lake Forest, CA 92630 USA***

***call: (949) 544-7500 - fax: (949) 544-7501***  
***Check out the following web sites for all of our kits, current products,  
new releases, setup help, tips, and racing info!***  
***[www.AssociatedElectrics.com](http://www.AssociatedElectrics.com)***

**FOLLOW US ON SOCIAL MEDIA**



**TeamAssociated**  
**ReedyPower**  
**ElementRC**  
**FactoryTeam51**



**@TeamAssociatedRC**  
**@ReedyPower**  
**@Element\_RC**  
**@FactoryTeam\_RC**



**@Team\_Associated**  
**@ReedyPower**



**@Associated\_Electrics**



**TeamAssociatedRC**  
**ElementRC**



**TeamAssociated**  
**Reedy**  
**Element-rc**