

RC Buggy Team Kit

RC Buggy Team Kit

TEAM ASSOCIATED

1:8 Scale 4WD Nitro Off Road Competition Buggy Kit Manual

#80954 RC10B4.2 Team Kit and #80956 RC10B4.2 EURO Team Kit



CHAMPIONS *by* DESIGN

AssociatedElectrics.com



:: Introduction

Thank you for purchasing this Team Associated product. This assembly manual contains instructions and tips for building and maintaining your new Kit. Please take a moment to read through this manual to help familiarize yourself with these steps. We are continually changing and improving our designs; therefore, actual parts may appear slightly different than in the illustrations. New parts will be noted on supplementary sheets located in the appropriate parts bags. Check each bag for these sheets before you start to build.

:: KIT Features

- New molded height-adjustable gearboxes front and rear
- New offset hubs and updated rear suspension arms to accommodate new hub geometry
- New -4mm chassis in FWB configuration
- (Euro Spec) New V2 FWB chassis
- New high-volume center differential
- New long chassis brace options
- New high-downforce wing
- Now includes FT hard-anodized aluminum shock bushings
- Updated brake pad material and brake spring
- Soft blend material suspension arms
- 8-degree KPI steering blocks included
- 44/13 ring and pinion gear sets
- 92mm universal driveshafts with 17mm outdrives
- 19mm diameter HTC internal differential gear set
- (Euro Spec) 20mm diameter HTC internal differential gear set
- Optimized setup for tracks with loose dirt and large bumps
- (Euro Spec) Optimized setup for high-speed and high-grip tracks

:: Additional

Your new RC8B4.2 Kit comes as a kit. There are some items you will need to complete your kit (refer to website for suggestions):

- 4.8-7.4v receiver battery (Flat style NiMH, Flat style LiPo, Flat style LiFe)
- 2 or 3 channel radio/transmitter set with switch (2.4GHz recommended)
- Model car fuel (20-30% nitro recommended)
- .21 class rear exhaust engine
- 1:8 scale buggy wheels / tires
- Polycarbonate-specific paint
- CA (cyanoacrylic) glue - (#1597)
- Throttle and Steering servos
- Transmitter batteries
- Glow igniter - (#27377)
- Needle-nose pliers
- Ride height gauge
- Hobby knife
- Starter box - (#1751)
- Exhaust system
- Fuel bottle - (#1747)
- Reamer / hole punch
- Thread-locking compound - (#1596)

:: Other Helpful Items

- Silicone Shock/Diff Fluids (Refer to website for complete listings)
- Shock Pliers
- Reamer / Hole Punch - (#1499)
- FT Hex Wrenches - (#1518)
- Wire Cutters
- Body Scissors (AE #1737)
- FT Nut Drivers - (#1519)
- Calipers or a Precision Ruler















Associated Electrics, Inc.
21062 Bake Parkway
Lake Forest, CA 92630

















Customer Service
Tel: 949.544.7500
Fax: 949.544.7501

:: Hardware - 1:1 Scale View







Flat Head (fhcs)

	2.5x6mm (4675)
	2.5x8mm (31448)
	3x5mm (31540)
	3x6mm (31541)
	3x8mm (25201)
	3x10mm (25202)
	3x12mm (25203)
	3x14mm (89208)
	3x30mm (89212)
	4x10mm (81262)
	4x12mm (89214)
	4x14mm (89217)
	4x16mm (81263)
	4x20mm (81264)







Button Head (bhcs)

	2.5x6mm (31520)
	2.5x8mm (31521)
	2.5x18mm (81259)
	3x6mm (31531)
	3x8mm (31532)
	3x10mm (25211)
	3x12mm (89202)
	3x14mm (25187)
	3x16mm (89203)
	3x18mm (2308)
	3x20mm (25188)
	3x22mm (25189)
	3x24mm (89204)
	4x14mm (81260)
	4x16mm (81261)







Set Screws

	3x3mm (25225)
	3x6mm (81257)
	3x10mm (4671)
	3x12mm (81258)
	4x4mm (7732)
	5x4mm (89221)





Ball Bearings

	5x8x2.5mm (8680)
	5x10x4mm (91560)
	6x10mm (31404)
	6x12x4mm (91561)
	8x16x5mm (91564)
	8x16x5mm flanged (91565)







Socket Head (shcs)

	2x5mm (31511)
	2x16mm (7184)
	3x10mm (25620)
	3x12mm (89454)
	3x24mm (89225)
	3x26mm (89226)
	3x28mm (89227)

LP Socket Head (lp shcs)

	3x6mm (41089)
	3x10mm (41090)
	3x14mm (41094)
	3x16mm (41093)
	3x20mm (41091)

Nuts (lock/plain)

	M3 Nut (91477)
	M3 Alum. Locknut, Blue (31550)
	M3 Locknut, Black (25215)
	M3 Locknut w/Flange (25612)
	FT 3mm Locknuts, Blue(25392)
	FT M4 Locknut, Blue (31551)
	M4 Locknut, Serrated (91738)

:: Table of Contents

1..... Cover	16 - 18.....Rear End Build (Bags 7.1, 7.2, 7.3)
2..... Introduction	19.....Rear Hubs Build (Bags 8.1, 8.2)
3..... 1:1 Hardware "Fold Out"	20 - 21.....Center Bulkhead Build (Bag 9.1)
4..... Table of Contents	21 - 22.....Linkages Build (Bag 10.1)
5 - 7.....Differentials Build (Bags 1.1, 1.2)	22 - 23.....Radio Tray Build (Bag 11.1)
7 - 8.....Shocks Build (Bag 2.1)	24 - 26.....Clutch / Filter Build (Bags 12.1, 12.2)
9.....Turnbuckles Build (Bags 3.1, 3.2)	26 - 27.....Fuel Tank Build (Bags 13.1, 13.2)
10 - 11.....Steering / Chassis Build (Bag 4.1)	27 - 28.....Wheels / Tires / Body (Misc.)
11 - 14.....Front Gearbox Build (Bags 5.1, 5.2, 5.3)	29..... Droop Settings
14 - 15.....Steering Blocks Build (Bags 6.1, 6.2)	30..... Back Cover

:: Notes



This symbol indicates a special note or instruction in the manual.



This symbol indicates a specific build order in the manual.



This symbol indicates a Racers Tip.



There is a 1:1 hardware foldout page in the front of the manual. To check the size of a part, line up your hardware with the correct drawing until you find the exact size. Each part in the foldout has a number assigned to it for ordering replacement parts.

**Associated Electrics, Inc.
21062 Bake Parkway
Lake Forest, CA 92630**



**Customer Service
Tel: 949.544.7500
Fax: 949.544.7501**

:: Differential Build (Front and Rear) - Bag 1.1, 1.2 - Step 1

#6588 black grease

81697
Outdrive
O-Ring
5.8x1.9mm

81379
Diff
Case

91564
8x16x5
Bearing

81381
Diff Shim
6x8x0.20mm

#6588 black grease

81012
17mm
Outdrive

81681
Pin
2.5x12mm

EURO KIT
81380
Diff Sun
Gear,
20mm HTC

81681
Diff Sun
Gear,
19mm HTC

Save 13.5 shims until install into gearbox

Align pin with groove in sun gear

:: Differential Build (Front and Rear) - Bag 1.1, 1.2 - Step 2

EURO KIT
81380 $\Sigma 4$
Diff Planet
Gears,
20mm HTC

81681 $\Sigma 4$
Diff Planet
Gears,
19mm HTC

81681 $\Sigma 2$
Diff
Crosspin

81681 $\Sigma 4$
Diff Shim
3.6x12x0.12mm

#6588 black grease

81468
Diff Ring
Gear,
44/13 Set

81381
Diff Shim
6x8x0.20mm

#6588 black grease

81697
Outdrive
O-Ring
5.8x1.9mm

91564
8x16x5
Bearing

81012
17mm
Outdrive

:: Differential Build (Front and Rear) - Bag 1.1, 1.2 - Step 3

81681
Pin
2.5x12mm

EURO KIT
81380
Diff Sun
Gear,
20mm HTC

81681
Diff Sun
Gear,
19mm HTC

81384
Diff
Gasket

#6588 black grease

Racer's Tip:
Use black grease (#6588) to coat the back side of the diff gasket (i.e. not the entire gasket) before installation!

Align pin with groove in sun gear

:: Differential Build (Front and Rear) - Bag 1.1, 1.2 - Step 4



Racer's Tip:

Fill diff above the cross pins, below the planet gears as shown.

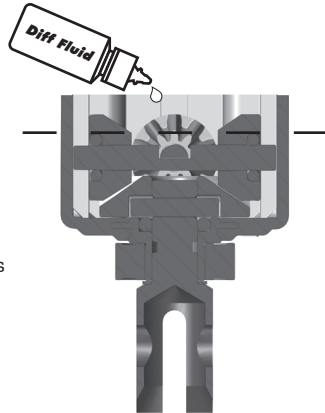

25202 x4
M3x10mm
FHCS

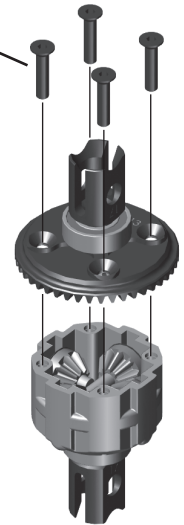

Front Diff Fluid:
Team Kit - 10,000cst #5455
Euro Kit - 60,000cst #5458

Rear Diff Fluid:
Team Kit - 5,000cst #5453
Euro Kit - 10,000cst #5455

:: Differential Build (Center) - Bag 1.1, 1.2 - Step 5

#6588 black grease

81697
Outdrive O-Ring
5.8x1.9mm

81703
B4.2 Diff Case

91564
8x16x5 Bearing

81381
Diff Shim
6x8x0.20mm

#6588 black grease

81012
17mm Outdrive, Center Diff

EURO KIT 81380
Diff Planet Gear Set, HTC

81681
Pin
2.5x12mm

EURO KIT 81380
Diff Sun Gear, 20mm HTC

81681
Diff Sun Gear, 19mm HTC

Align pin with groove in sun gear

:: Differential Build (Center) - Bag 1.1, 1.2 - Step 6

81681 x4
Diff Planet Gear, 10T, HTC

81704 x2
B4.2 Center Diff Crosspin

81681 x4
Diff Shim
3.6x12x0.12mm

#6588 black grease

81697
Outdrive O-Ring
5.8x1.9mm

81707
B4.2 Spur Gear, 47T

EURO KIT 81706
B4.2 Spur Gear, 46T

91564
8x16x5 Bearing

81381
Diff Shim
6x8x0.20mm

#6588 black grease

81012
17mm Outdrive, Center Diff

:: Differential Build (Center) - Bag 1.1, 1.2 - Step 7

81681
Pin
2.5x12mm

EURO KIT
81380
Diff Sun Gear,
20mm HTC

81681
Diff Sun Gear,
19mm HTC

81705
B4.2 Center Diff Gasket,
0.5mm

#6588 black grease

Racer's Tip:
Use black grease (#6588) to coat the back side of the diff gasket (i.e. not the entire gasket) before installation!

Align pin with groove in sun gear

:: Differential Build (Center) - Bag 1.1, 1.2 - Step 8

Racer's Tip:
Fill diff above the cross pins, below the planet gears as shown.

25202 **M3x10mm FHCS**

Center Diff Fluid:
Team Kit - 10,000cst #5455
Euro Kit - 30,000cst #5457

:: Shocks Build - Bag 2.1 - Step 1

EURO KIT
81210
FT Shock Piston
(8x1.2 tapered)
Front

81202
FT Shock Piston
(6x1.3 flat)
Front

89215
2.5mm Shock Piston Locknut

81162
Shock Body,
26.5mm
(Front)

EURO KIT
81211
FT Shock Piston
(8x1.3 tapered)
Rear

81597
FT Shock Piston
(6x1.4 tapered)
Rear

89278 **2.6x6mm Washer**

81172
TiN Shock Shaft,
3.5x33.5mm
(Front)

81173
TiN Shock Shaft,
3.5x42.5mm
(Rear)

81185
Shock Body O-Ring

81185
O-Ring Hat Bushing

81188
Shock Body Seal Retainer

81163
Shock Body,
36.5mm
(Rear)

81186 **Shock O-Ring**

81185
O-Ring Spacer

Install pistons taper down

:: Shocks Build - Bag 2.1 - Step 2

Racer's Tip:
Use green slime (#1105) to lube the o-rings before installation!

81190 Shock Boots
81562 Rod End Ball
81452 RC8B3.2 Shock Cap
81621 Shock Rod End
Front: +2
Rear: +2
81512 Shock Cap Insert
91492 M2x4mm BHCS
91492 Gasket 2
81184 Emulsion Seal 1
EURO KIT 81453 16mm Stiff Bladder

!
When installing the emulsion seal, make sure it is correctly seated within the shock cap as shown.

:: Shocks Build - Bag 2.1 - Step 3

Racer's Tip:
Euro Kit comes with bladder style shocks. There is a different bleeding procedure for this style of shock build.

!
Fill to top of shock body.

!
Tighten to snug, may be a small gap when sealed.

!
Bleed Procedure:
Remove bleeder screw
Tilt shock so bleed hole is the highest point and slowly compress the shaft.
Stop about 3mm from full compressed, install the screw, and check that the shock is not pressurized. If so, bleed out a small amount more.

Front Shock Fluid:
Team Kit - 40wt #5423
Euro Kit - 50wt #5435

Rear Shock Fluid:
Team Kit - 35wt #5429
Euro Kit - 45wt #5430

:: Shocks Build - Bag 2.1 - Step 4

!
The springs come with a colored marking pre-installed for easy identification

81221 Spring Collar O-Ring, 20mm
81221 Spring Collar, 20mm
81659 16mm Front Spring, Green (4.85lb/in) L68, 8.00T, 1.5D
81663 16mm Rear Spring, Green (3.60lb/in) L83, 10.0T, 1.5D
EURO KIT 81223 16mm Front Spring, White (5.10lb/in) L70, 9.25T, 1.6D
EURO KIT 81229 16mm Rear Spring, White (4.10lb/in) L86, 11.0T, 1.6D
81512 Spring Cup 1
25211 M3x10mm BHCS 2

:: Turnbuckles Build - Bag 3.1 - Step 1

Steering Servo Turnbuckle

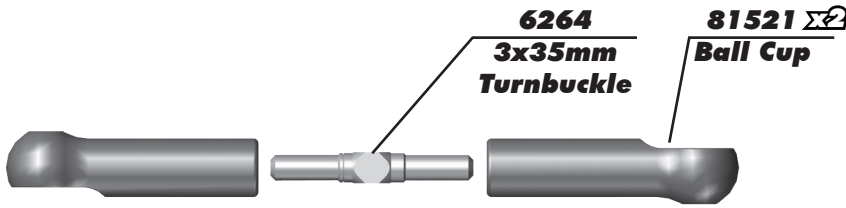

15.00mm (0.59")

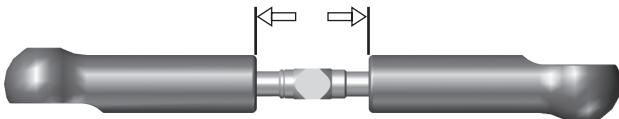

Set aside until page 22

:: Turnbuckles Build - Bag 3.1 - Step 2

Steering Turnbuckle

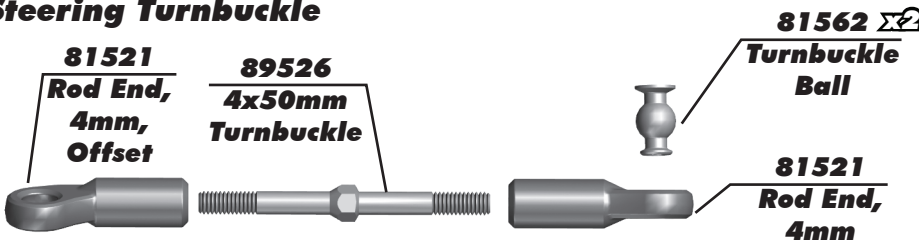

24.20mm (0.952")



Left Turnbuckle



Right Turnbuckle



Note the direction of turnbuckle ball



Set aside until page 15

:: Turnbuckles Build - Bag 3.1 - Step 3

Rear Hub Turnbuckle

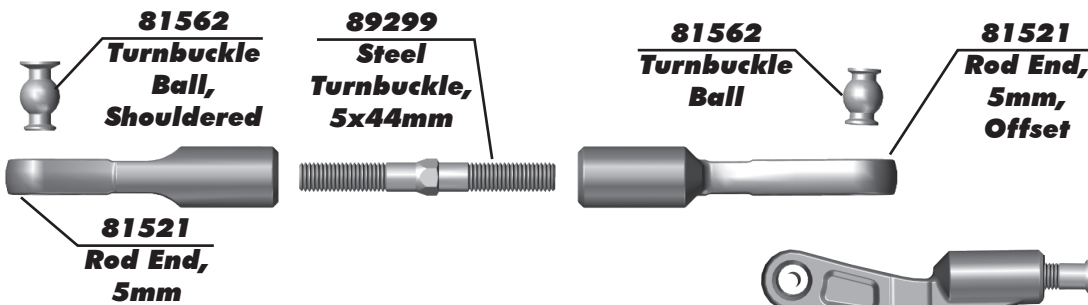

13.70mm (0.539")

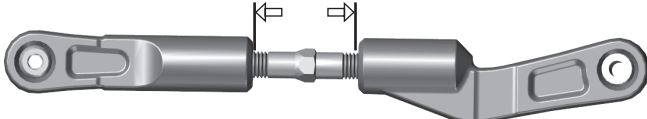

Left Turnbuckle

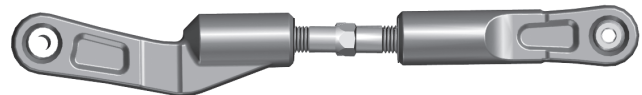

Right Turnbuckle



Set aside until page 19

:: Steering / Chassis Build - Bag 4.1 - Step 1

1
31540 $\times 3$
M3x5mm FHCS

81631
B4.1 Side Guards

2
25201 $\times 2$
M3x8mm FHCS

81683
RC8B4.2 Chassis FWB, -4mm

81686
RC8B4.2 Chassis FWB, V2

EURO KIT

81091 $\times 2$
Steering Post

81262 $\times 2$
M4x10mm FHCS

#1596 thread lock
 (not included)

Loosely attach 3x5mm FHCS and then install 3x8mm FHCS. Tighten after all screws are installed

:: Steering / Chassis Build - Bag 4.1 - Step 2

81084
Servo Saver Tube

81516
Steering Bellcrank

81562
Steering Link Pivot Ball

89202
M3x12mm BHCS

81516
Servo Saver Arm

#6588 black grease

#1596 thread lock

Racer's Tip:
 Use black grease (#6588) to lube the bellcrank halves before installation!

81083
Servo Saver Spring

81084 $\times 2$
Servo Saver Tube Shim

81084
Servo Saver Tube Spring Nut & O-Ring

:: Steering / Chassis Build - Bag 4.1 - Step 3

1.5mm

31404 $\times 4$
6x10x3mm Bearing

81516
Steering Bellcrank

8680 $\times 4$
5x8x2.5mm Bearing

:: Steering / Chassis Build - Bag 4.1 - Step 4

25201 $\Sigma 2$
M3x8mm FHCS

81518
Steering Rack

81517 $\Sigma 2$
Steering Bellcrank Nut

#1596
thread lock

3mm hex wrench fits bellcrank nut hex.

:: Front Gearbox Build - Bag 5.1, 5.2, 5.3 - Step 1

Pinion Height Insert:
Dot at bottom = 0
No dot = +1
Dot at top = +2

81689
B4.2 Pinion Height Insert, Team Kit +1 Euro Kit +2

4675 $\Sigma 2$
M2.5x6mm FHCS

91561 $\Sigma 2$
6x12x4mm Bearing

#6588
black grease

81468
Diff Pinion Gear, 44/13 set

81687
Dust Cap

4675
2.5x6mm FHCS

81687
B4.2 Gearbox, (Inboard)

81687 $\Sigma 2$
B4.2 Gearbox Flange Insert, Middle

#1596
thread lock

89221
5x4mm Set Screw

81564
Dogbone Outdrive, Front

Racer's Tip:
Clearance here for easier diff installation.

Racer's Tip:
De-grease and clean set screw and cup for best thread lock.

:: Front Gearbox Build - Bag 5.1, 5.2, 5.3 - Step 2

81689 $\Sigma 2$
B4.2 Gearbox Diff Height Insert, Team Kit +1 Europ Kit +2

81381
Diff Shim 13.5x15.8x0.20mm

25620 $\Sigma 2$
M3x10mm SHCS

81687
Anti-Roll Bar Cap

81687
B4.2 Gearbox, (Outboard)

#6588
black grease

STEP 1

STEP 2

Step 1:
Add shims on the ring gear side to TIGHTEN gear mesh. Subtract shims on this side to LOOSEN gear mesh.
NOTE:
Start 1x Thick 0.2mm

Step 2:
Add or subtract shims here to finalize diff side to side play once gear mesh is set from Step 1.
Recommended diff "side-to-side" clearance (gearbox assembly) 0.10 - 0.25mm. Start with 1 x 0.1mm.

Note:
0.1 mm shim can be used for fine tuning of gear mesh

:: Front Gearbox Build - Bag 5.1, 5.2, 5.3 - Step 3

Kit Setup:



Drop Screw:

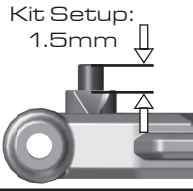

!
Start here, adjust to 102mm shock length.

Build left and right side!

81520 $\Sigma 2$
Arm Mount Insert, Center

81567
Arm Mount B

81260 $\Sigma 2$
M4x14mm BHCS

81566
Arm Mount A

81260 $\Sigma 2$
M4x14mm BHCS

81520 $\Sigma 2$
Arm Mount Insert, Center

81641 $\Sigma 2$
B4.1 Hinge Pin, 66.3mm

89317
Drop Screw

81446 $\Sigma 2$
Suspension Arm Shim

81636
Front Lower Arm, Soft

:: Front Gearbox Build - Bag 5.1, 5.2, 5.3 - Step 4

81512 $\Sigma 2$
Anti-Roll Bar Link

81585
Anti-Roll Bar Pivot

81562
Rod End Ball

!
Note direction

89203 $\Sigma 2$
M3x16mm BHCS

:: Front Gearbox Build - Bag 5.1, 5.2, 5.3 - Step 5

!
Center the anti-roll bar collet on the anti-roll bar; then tighten the 3x3mm set screw.

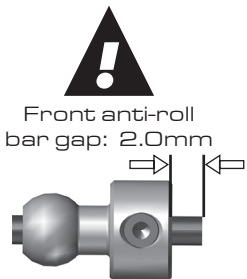

!
Front anti-roll bar gap: 2.0mm

81129
(Front) Anti-Roll Bar, Team Kit - 2.1mm Euro Kit - 2.2mm

81585
Anti-Roll Bar Collet

25225
3x3mm Set Screw

!
Center!

!
Note direction

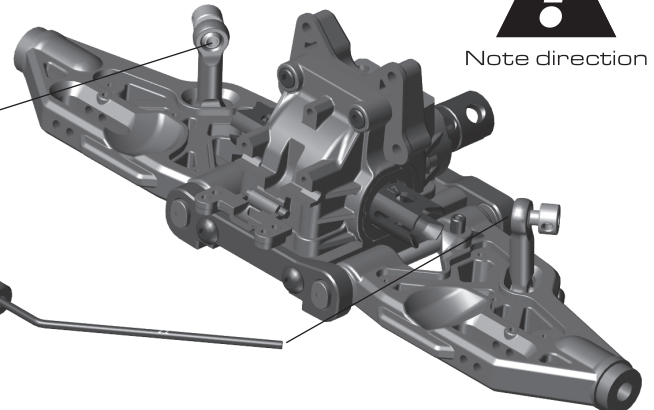

:: Front Gearbox Build - Bag 5.1, 5.2, 5.3 - Step 6



Tighten 3x6mm set screws just enough to still allow the anti-roll bar to move freely.

31521 $\Sigma 2$
M2.5x8mm
BHCS

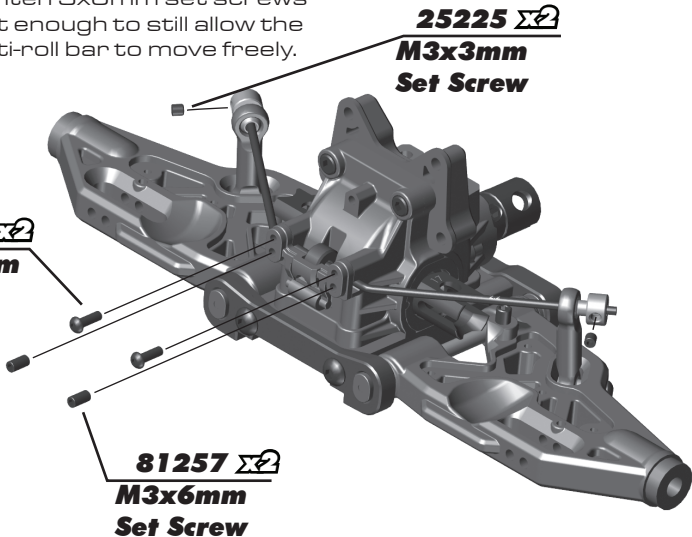

81257 $\Sigma 2$
M3x6mm
Set Screw

25225 $\Sigma 2$
M3x3mm
Set Screw

89214
M4x12mm
FHCS

89216
M4
Locknut

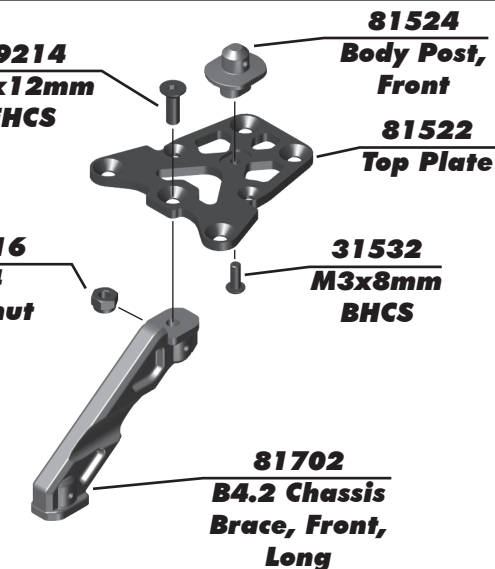

81524
Body Post,
Front

81522
Top Plate

31532
M3x8mm
BHCS

81702
B4.2 Chassis
Brace, Front,
Long

:: Front Gearbox Build - Bag 5.1, 5.2, 5.3 - Step 7

Kit Setup:



31541 $\Sigma 2$
M3x6mm
FHCS

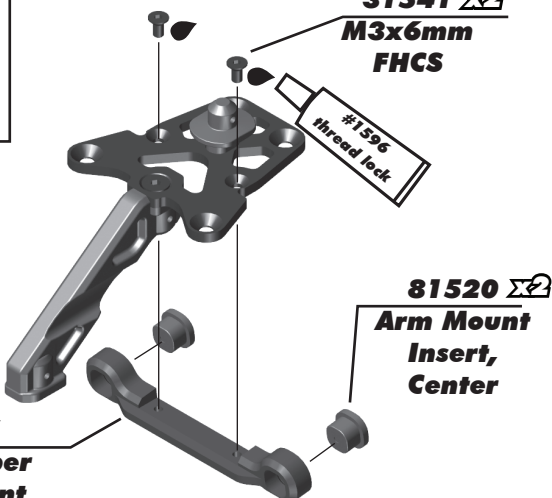

81647
B4.1 Upper
Link Mount,
Angled

81520 $\Sigma 2$
Arm Mount
Insert,
Center

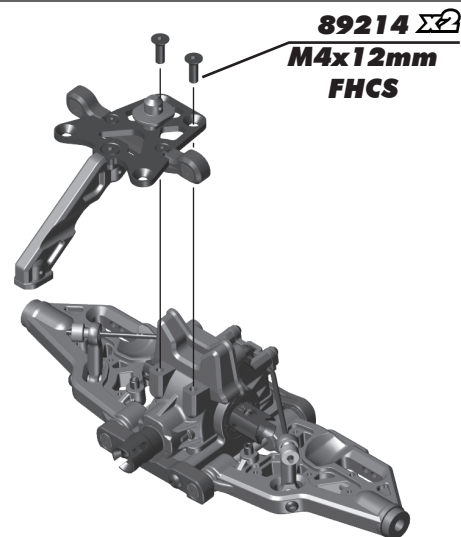

89214 $\Sigma 2$
M4x12mm
FHCS

:: Front Gearbox Build - Bag 5.1, 5.2, 5.3 - Step 8

Kit Setup:



89226 $\Sigma 2$
M3x26mm
SHCS

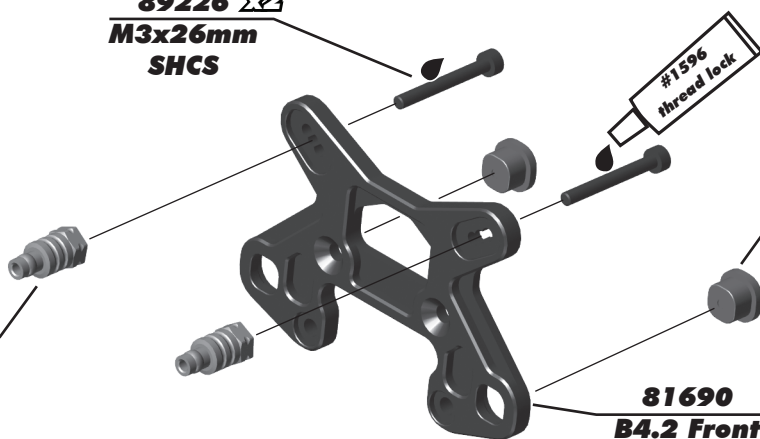

81591 $\Sigma 2$
FT Shock
Bushing,
14mm

81690
B4.2 Front
Shock Tower,
8deg KPI

!
Install arm
mount inserts in
direction shown!

81520 $\Sigma 2$
Arm Mount
Insert,
Side

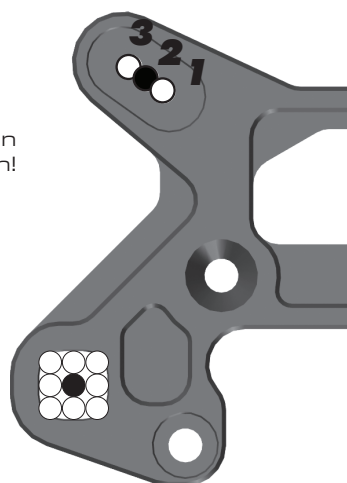

:: Front Gearbox Build - Bag 5.1, 5.2, 5.3 - Step 9

Build left and right side!

Add 1.0mm caster clip behind suspension arm. Adjust final arm spacing by adding remaining clips in front of arm until fit is tight and the arm rotates freely.

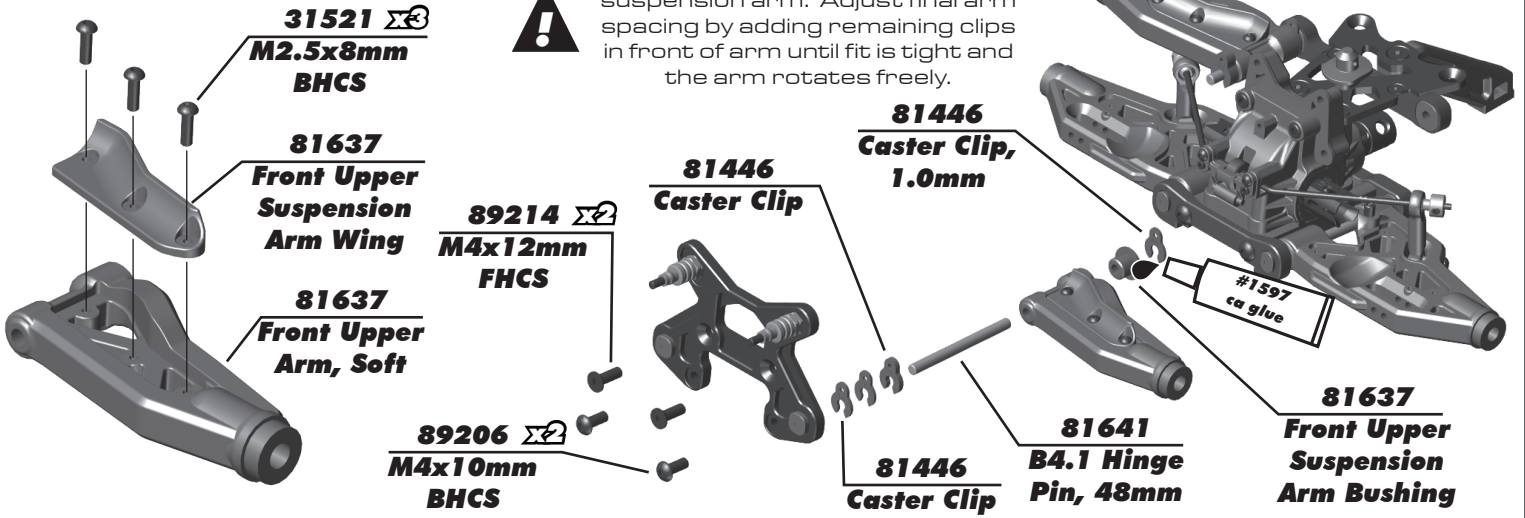

:: Steering Blocks Build - Bag 6.1 - Step 1

Build left and right side!

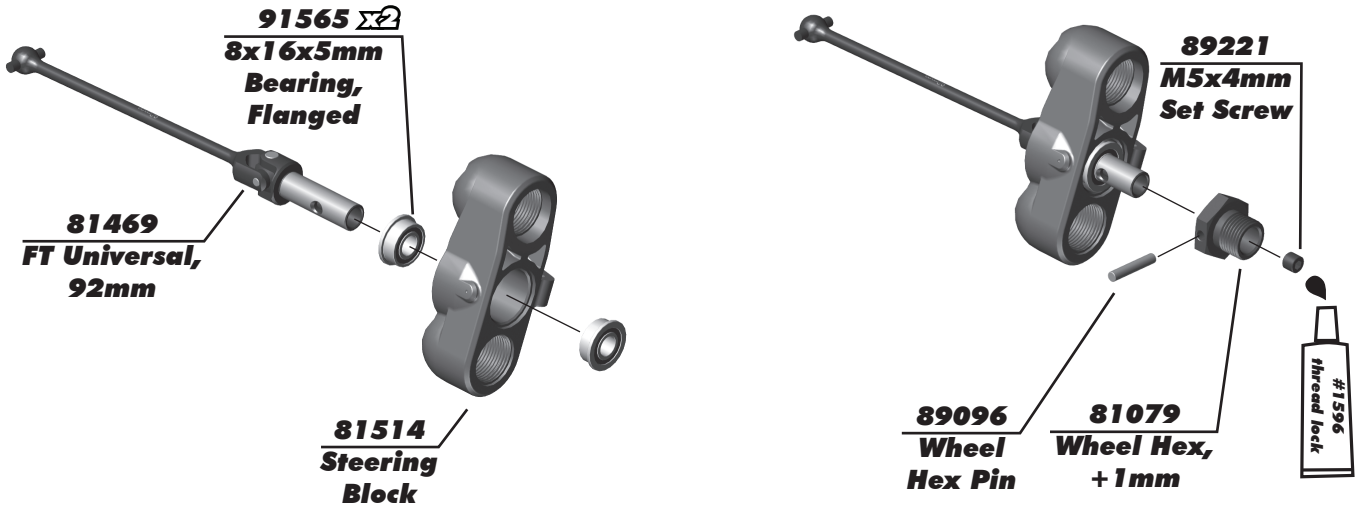

:: Steering Blocks Build - Bag 6.1 - Step 2

Build left and right side!

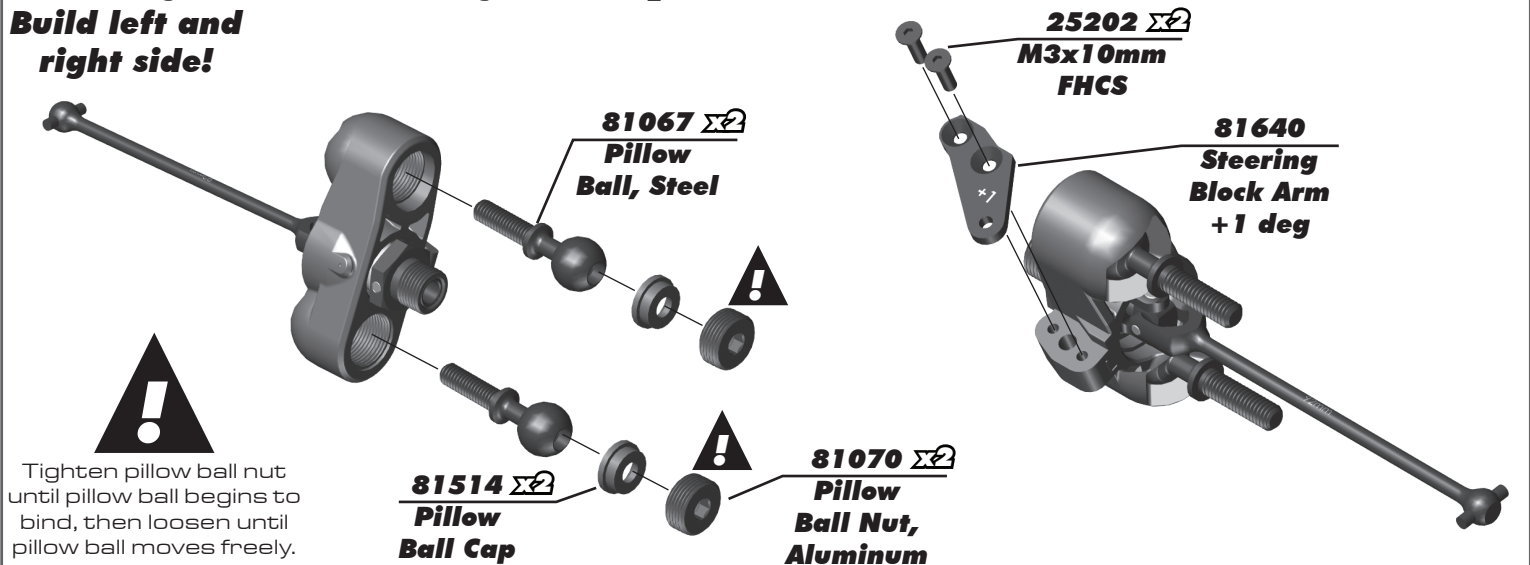

:: Steering Blocks Build - Bag 6.1 - Step 3

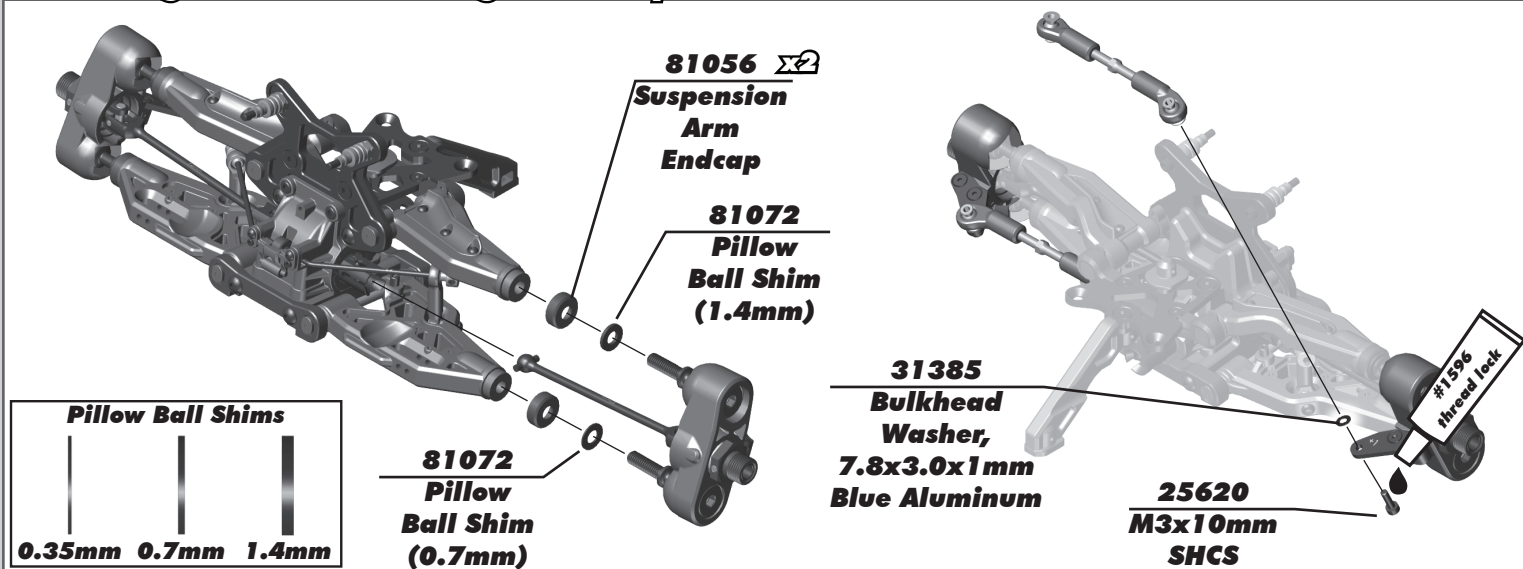

:: Steering Blocks Build - Bag 6.1 - Step 4

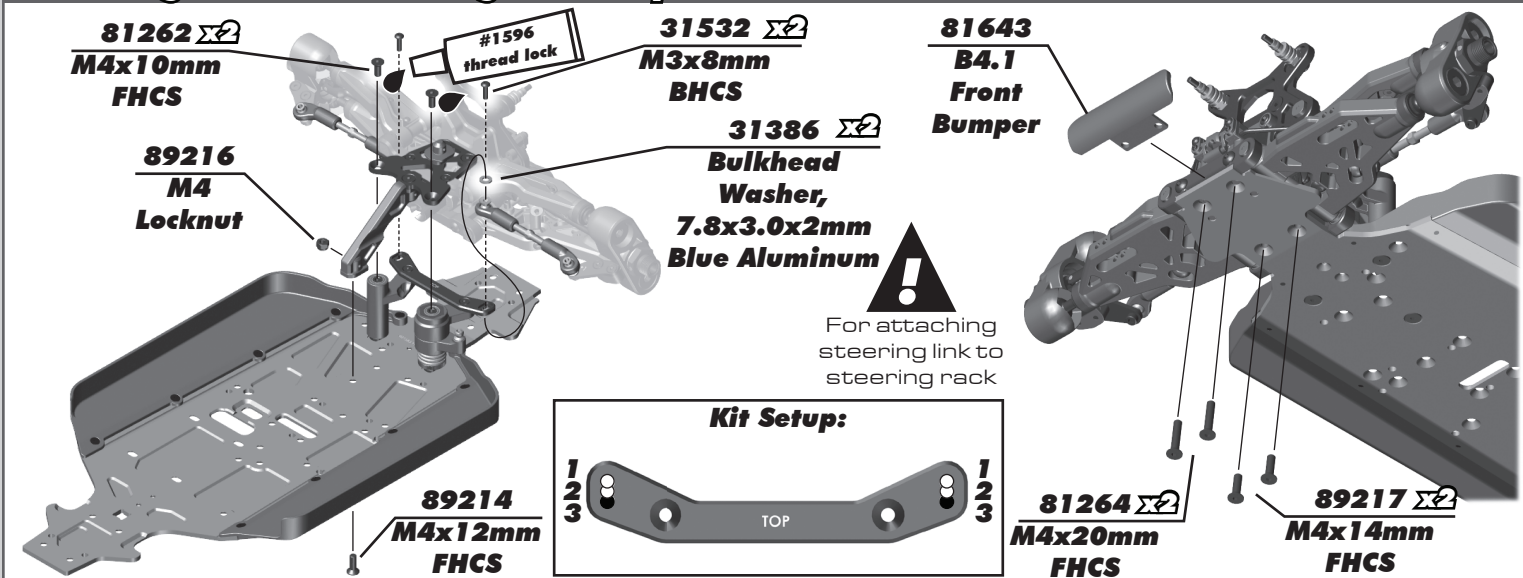

:: Steering Blocks Build - Bag 6.1 - Step 5

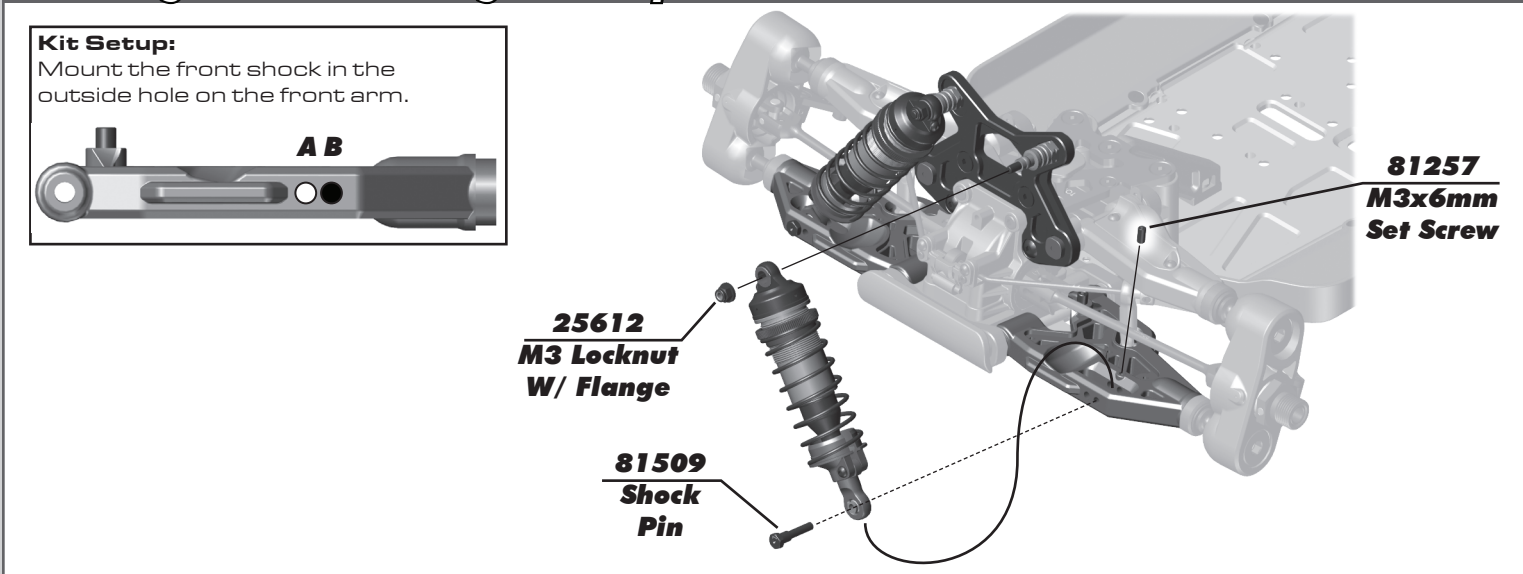

:: Rear End Build - Bag 7.1, 7.2, 7.3 - Step 1

Pinion Height Insert:
 Dot at bottom = 0
 No dot = +1
 Dot at top = +2

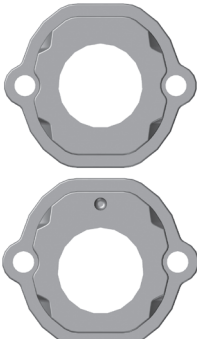

81689 B4.2 Pinion Height Insert, Team Kit 0 Euro Kit +1

4675 M2.5x6mm FHCS

#6588 black grease

81468 Diff Pinion Gear, 44/13 set

81688 Dust Cap

4675 M2.5x6mm FHCS

81688 B4.2 Gearbox, (Inboard)

81688 B4.2 Gearbox Flange Insert, Low

81565 Dogbone Outdrive, Rear

#1596 thread lock

89221 M5x4mm Set Screw

91561 6x12x4mm Bearing

Racer's Tip: Clearance here for easier diff installation.

Racer's Tip: De-grease and clean set screw and cup for best thread lock.

:: Rear End Build - Bag 7.1, 7.2, 7.3 - Step 2

81689 B4.2 Gearbox Diff Height Insert, Team Kit 0 Europ Kit +1

Gearbox Diff Height:
 Dot at bottom = 0
 No dot = +1
 Dot at top = +2

25620 M3x10mm SHCS

81688 Anti-Roll Bar Cap

81381 Diff Shim 13.5x15.8x0.20mm

81688 B4.2 Gearbox, (Outboard)

#6588 black grease

STEP 1

STEP 2

Step 1:
 Add shims on the ring gear side to TIGHTEN gear mesh. Subtract shims on this side to LOOSEN gear mesh.
 NOTE:
 Start 1x Thick 0.2mm

Step 2:
 Add or subtract shims here to finalize diff side to side play once gear mesh is set from Step 1. Recommended diff "side-to-side" clearance [gearbox assembly] 0.10 - 0.25mm. Start with 1 x 0.1 mm.

Note:
 0.1 mm shim can be used for fine tuning of gear mesh

:: Rear End Build - Bag 7.1, 7.2, 7.3 - Step 3

Kit Setup:



81454 Arm Mount, HRC, Narrow (C)

81260 M4x14mm BHCS

81520 Arm Mount Insert, Center

:: Rear End Build - Bag 7.1, 7.2, 7.3 - Step 4

Kit Setup:



Droop Screw:
Kit Setup:
1.5mm

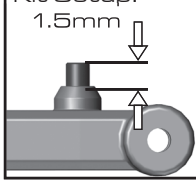

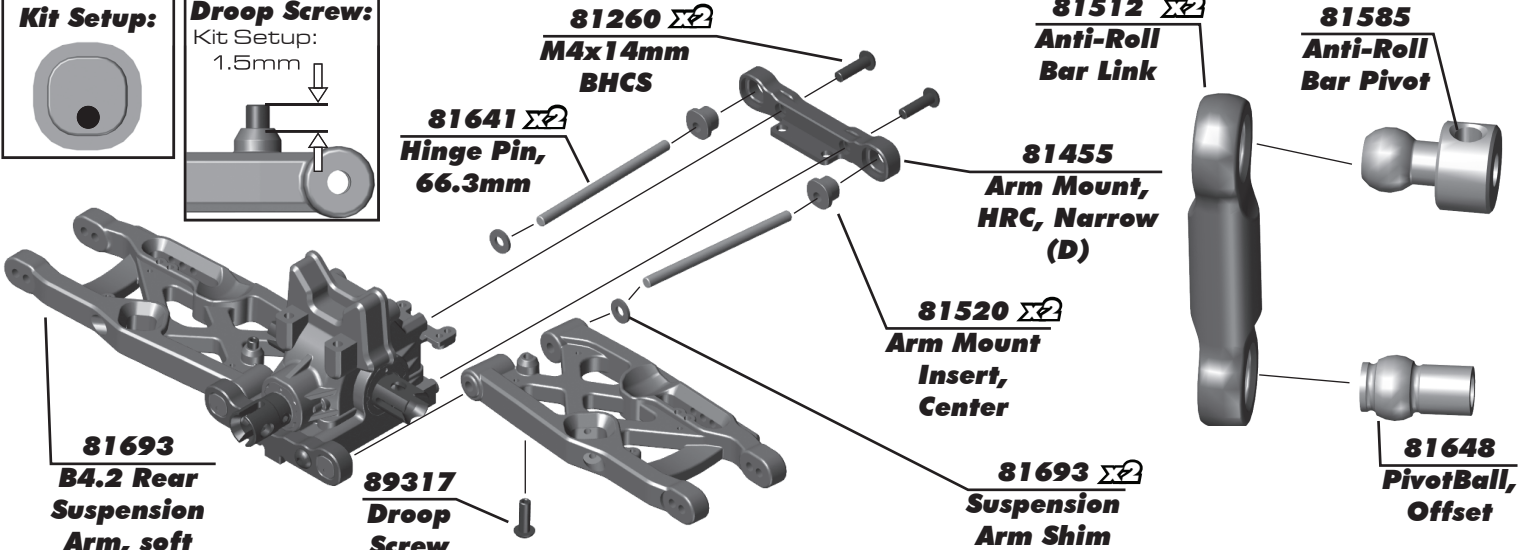

- 81260** $\Sigma 2$
M4x14mm
BHCS
- 81641** $\Sigma 2$
Hinge Pin,
66.3mm
- 81512** $\Sigma 2$
Anti-Roll
Bar Link
- 81585**
Anti-Roll
Bar Pivot
- 81455**
Arm Mount,
HRC, Narrow
(D)
- 81520** $\Sigma 2$
Arm Mount
Insert,
Center
- 81693** $\Sigma 2$
Suspension
Arm Shim
- 81693**
B4.2 Rear
Suspension
Arm, soft
- 89317**
Droop
Screw
- 81648**
PivotBall,
Offset

:: Rear End Build - Bag 7.1, 7.2, 7.3 - Step 5

!

Rear Anti-Roll Bar Tuning:
Ball wide = more rigid,
less rotation [*kit]
Ball narrow = more soft,
more rotation

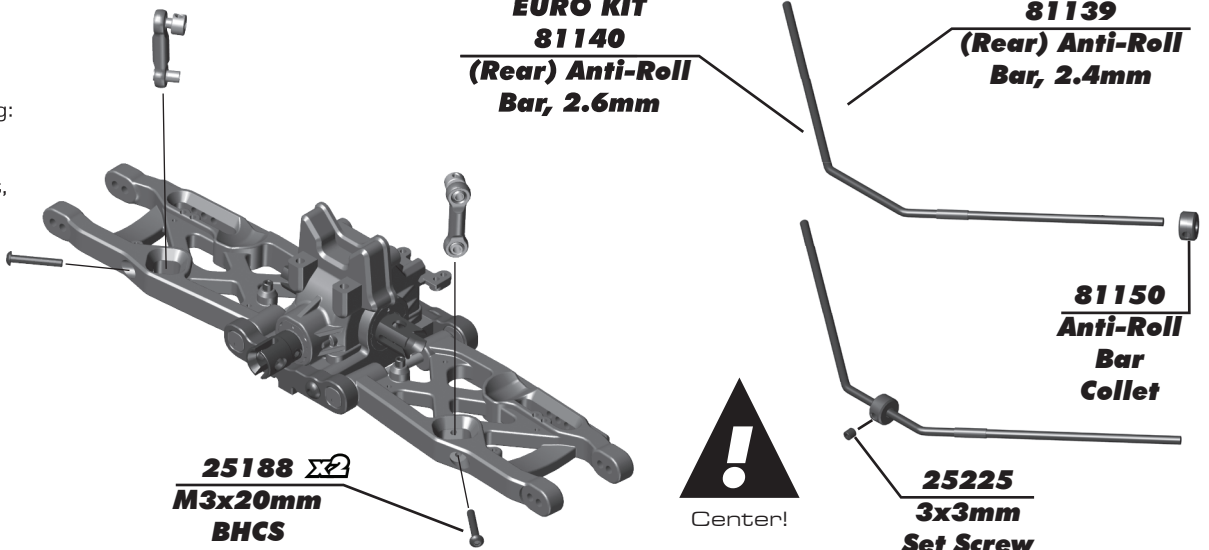

- EURO KIT**
81140
(Rear) Anti-Roll
Bar, 2.6mm
- 81139**
(Rear) Anti-Roll
Bar, 2.4mm
- 81150**
Anti-Roll
Bar
Collet
- 25225**
3x3mm
Set Screw
- 25188** $\Sigma 2$
M3x20mm
BHCS
- Center!**

:: Rear End Build - Bag 7.1, 7.2, 7.3 - Step 6

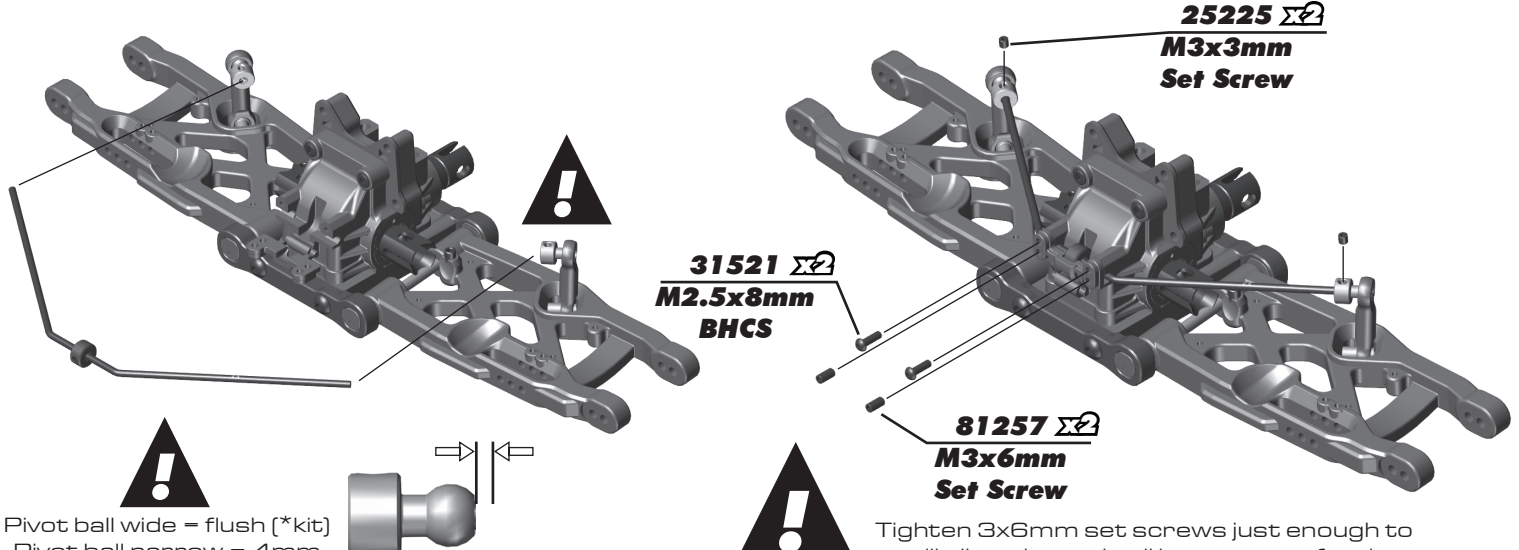

- 25225** $\Sigma 2$
M3x3mm
Set Screw
- 31521** $\Sigma 2$
M2.5x8mm
BHCS
- 81257** $\Sigma 2$
M3x6mm
Set Screw

!

Pivot ball wide = flush [*kit]
Pivot ball narrow = 4mm

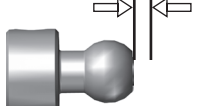

!

Tighten 3x6mm set screws just enough to
still allow the anti-roll bar to move freely.

:: Rear End Build - Bag 7.1, 7.2, 7.3 - Step 7

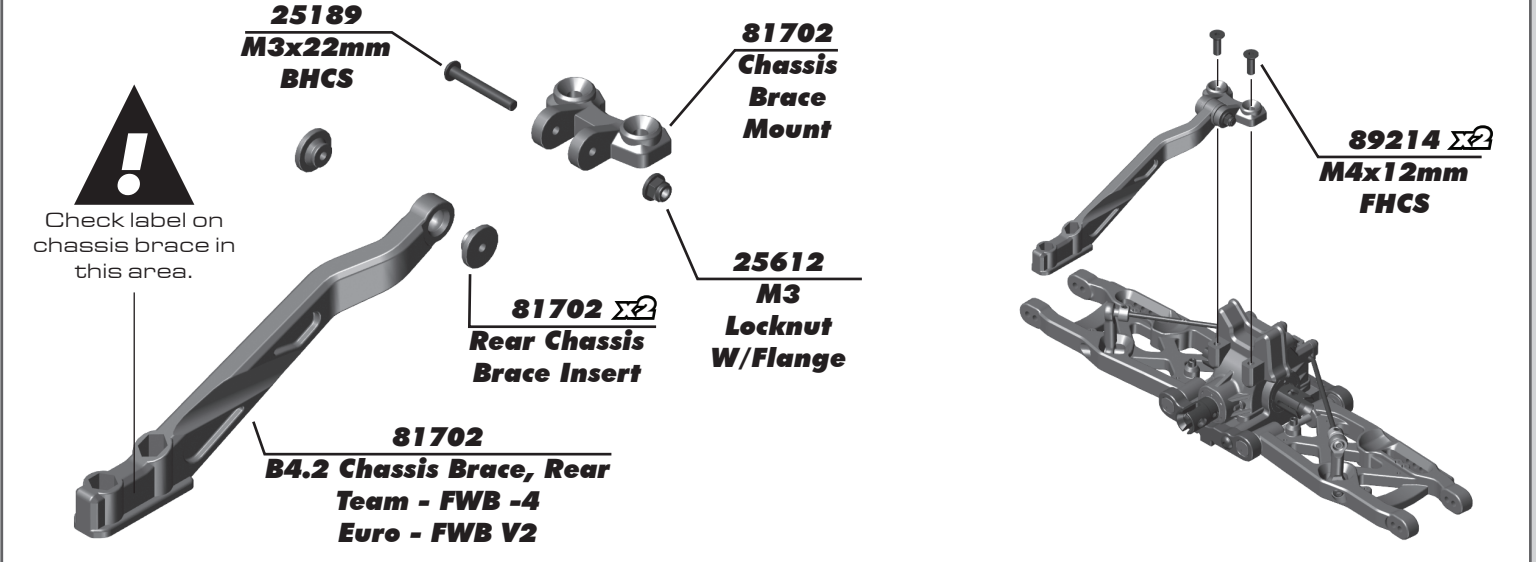

:: Rear End Build - Bag 7.1, 7.2, 7.3 - Step 8

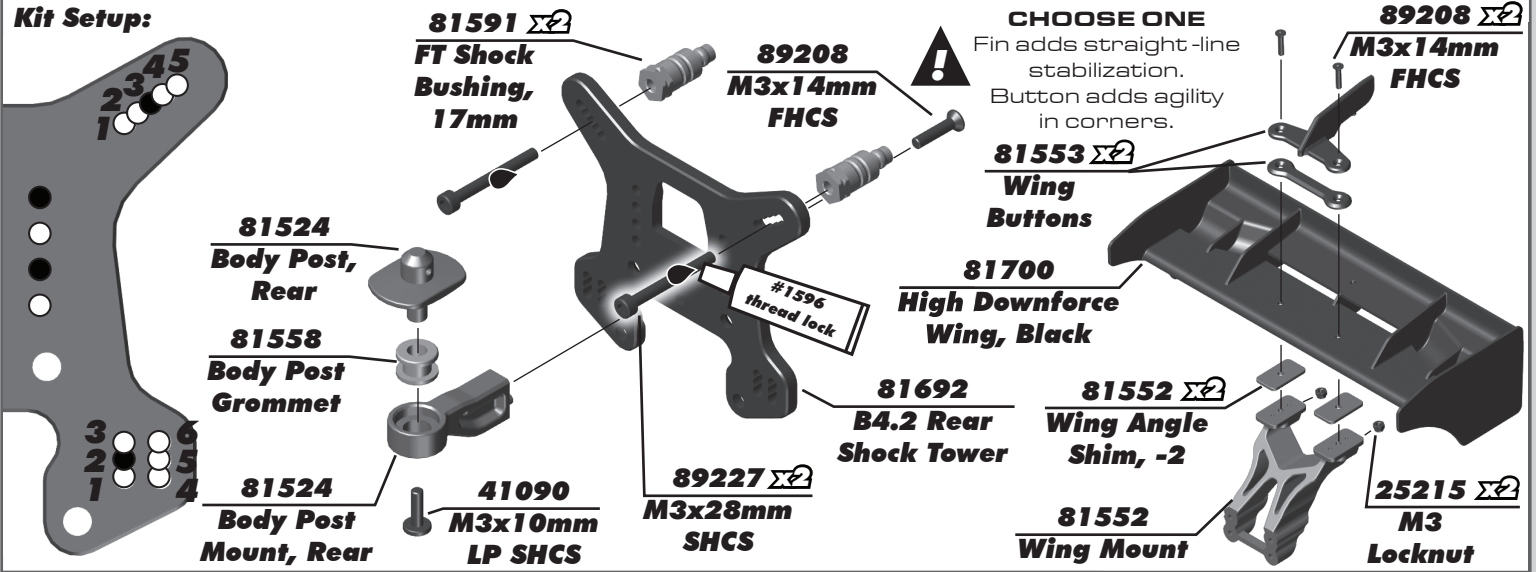

:: Rear End Build - Bag 7.1, 7.2, 7.3 - Step 9

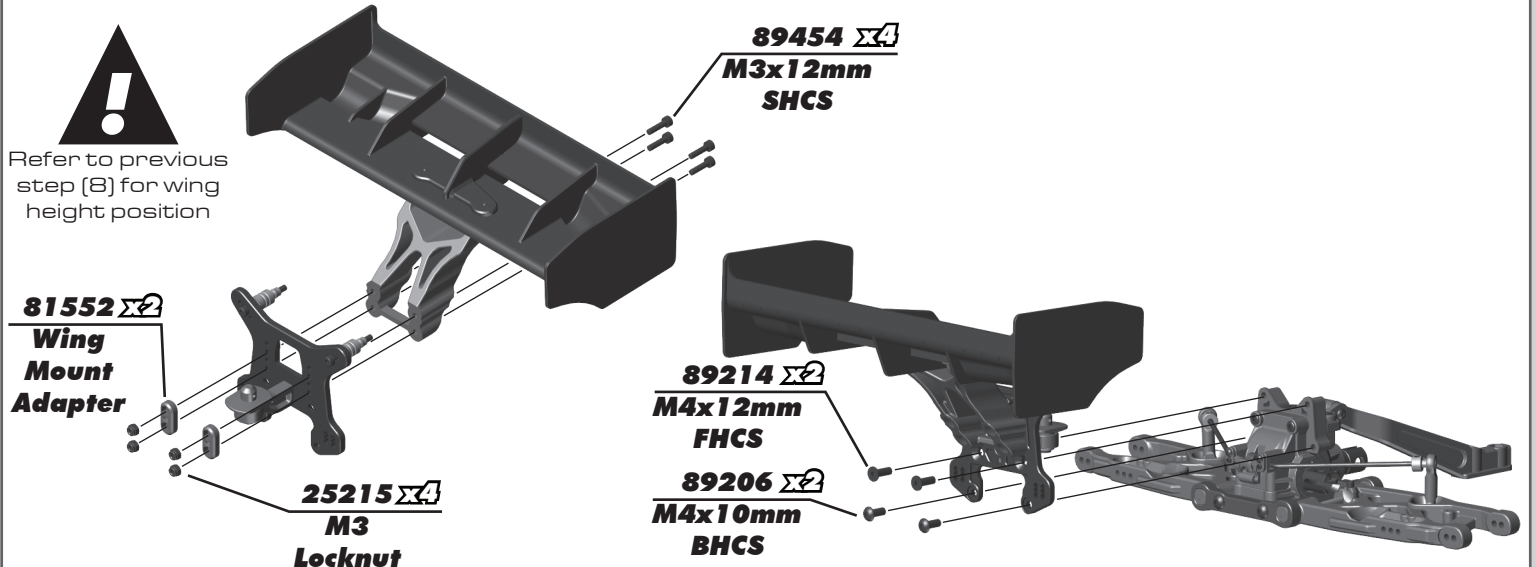

:: Rear Hubs Build - Bag 8.1, 8.2 - Step 1

Build two!

81649 B3 FT Universals, 92mm

81257 3x6mm Set Screw

89096 Wheel Hex Pin

81079 Wheel Hex, +1mm Wide

89221 5x4mm Set Screw

91564 8x16x5mm Bearing

25215 M3 Locknut

81695 B4.2 Rear Hubs, Offset

25188 M3x20mm BHCS

81649 B4.1 Rear Hub Plates (standard)

! Tighten set screw before camber link installation.

Racer's Tip: Use a 2mm drill to punch thru the thin wall between set screws and the hinge pin. Tighten after installation to remove slop.

:: Rear Hubs Build - Bag 8.1, 8.2 - Step 2

Install left and right side!

81695 B4.2 Rear Hub Shim, 1mm

25612 M3 Locknut w/Flange

81076 Hub Hinge Pin

25192 M3x20mm SHCS

25620 M3x10mm SHCS

25612 M3 Locknut w/Flange

Kit Setup: B4.2 offset hubs use short arm hole.

Kit Setup: Mount the rear shock in the outside hole on the rear arm.

:: Rear Hubs Build - Bag 8.1, 8.2 - Step 3

Tuning Tip: Remove screw A for "soft/short" flex configuration.

89216 M4 Locknut

81264 M4x20mm FHCS

89217 M4x14mm FHCS

89214 M4x12mm FHCS

25612 M3 Locknut W/ Flange

81509 Shock Pin

81257 M3x6mm Set Screw

A B

:: Center Bulkhead - Bag 9.1 - Step 1

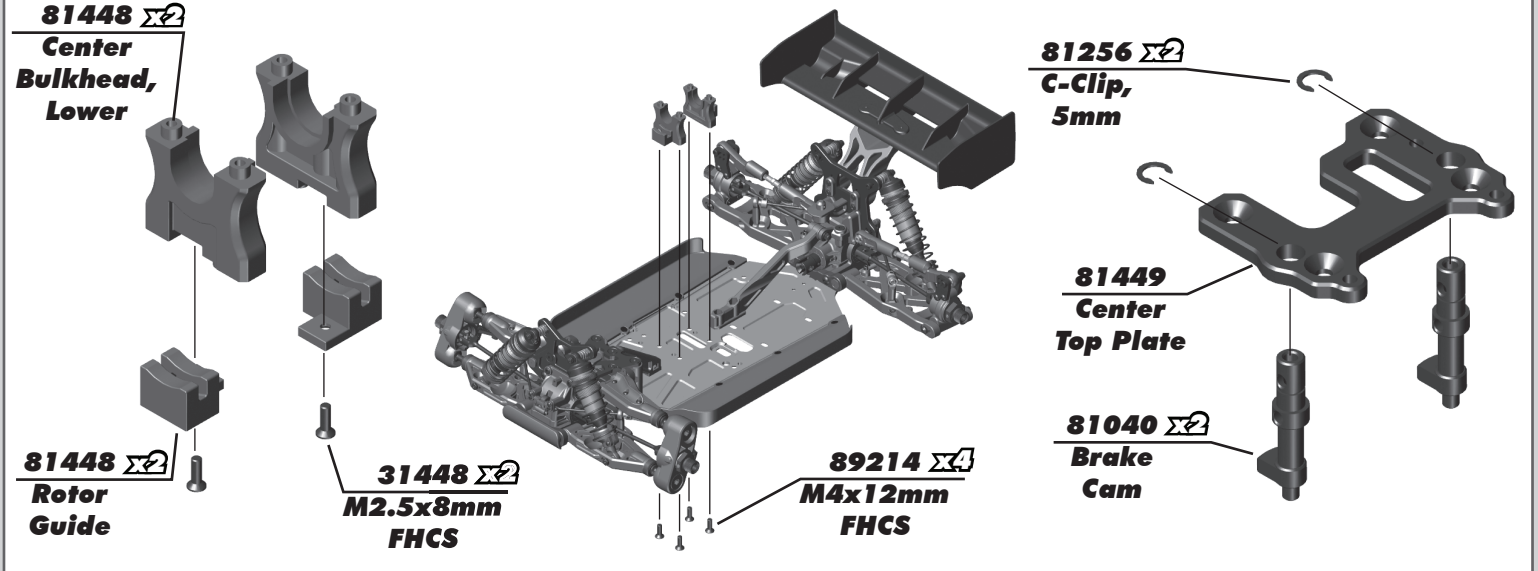

:: Center Bulkhead - Bag 9.1 - Step 2

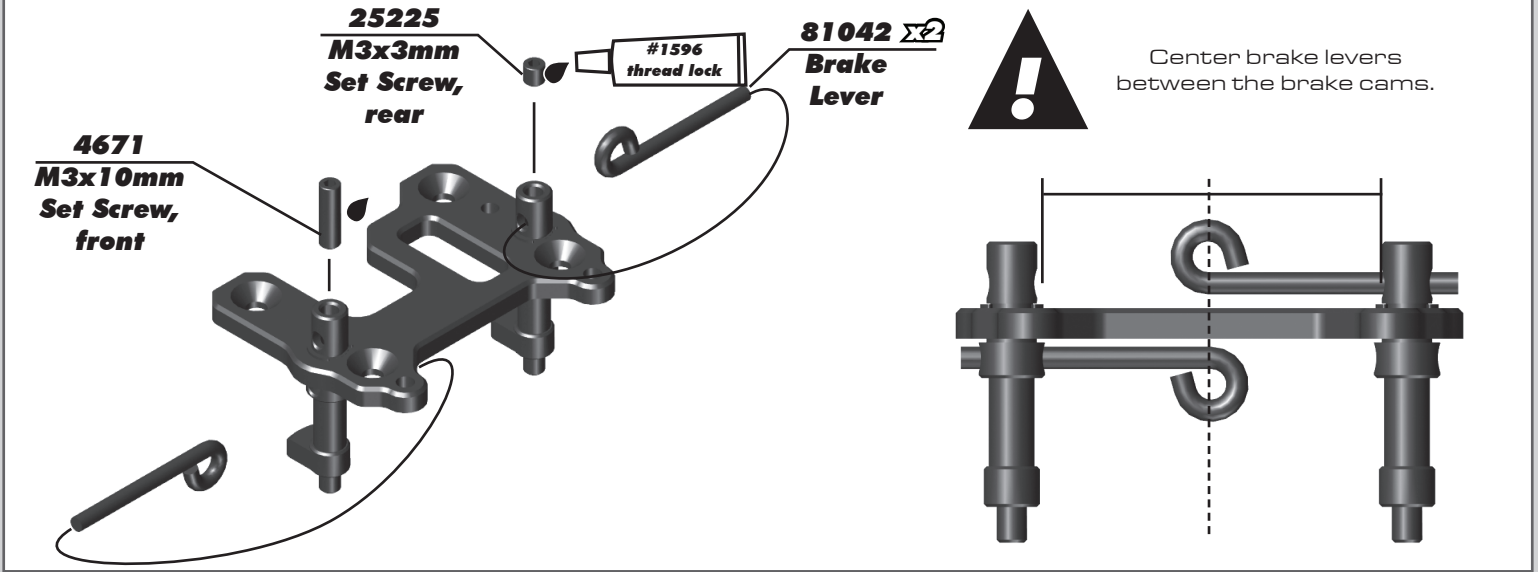

:: Center Bulkhead - Bag 9.1 - Step 3

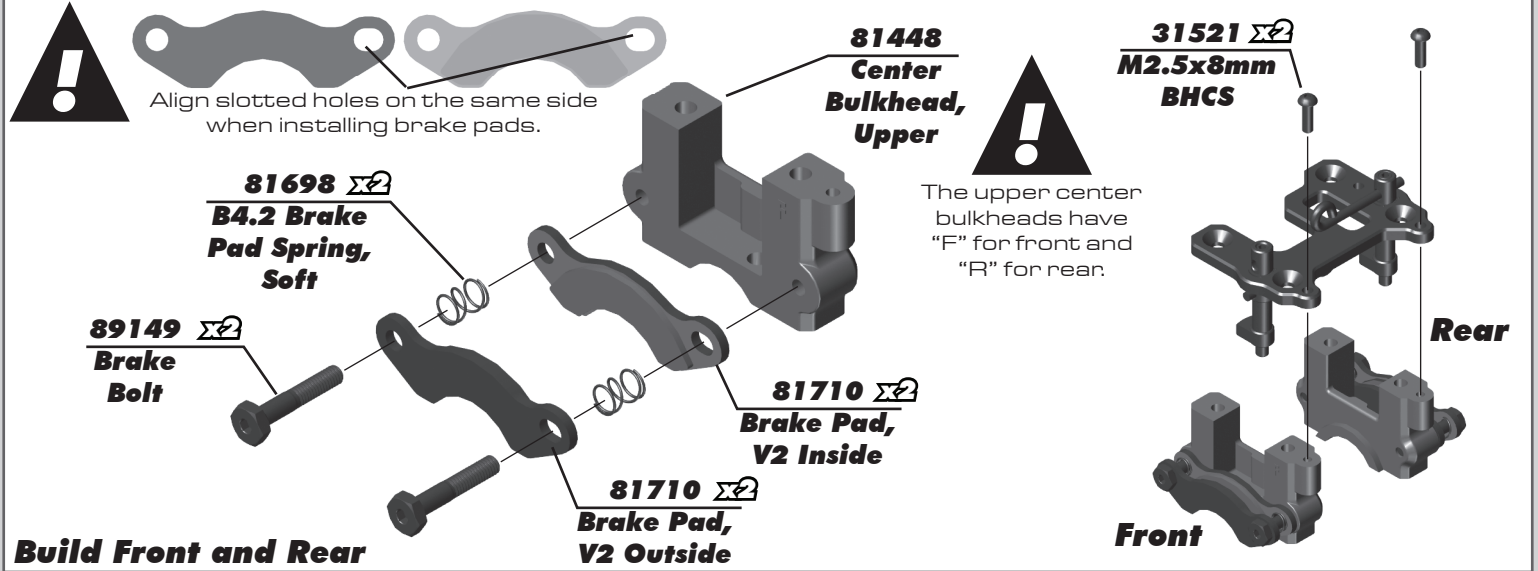

:: Center Bulkhead - Bag 9.1 - Step 4

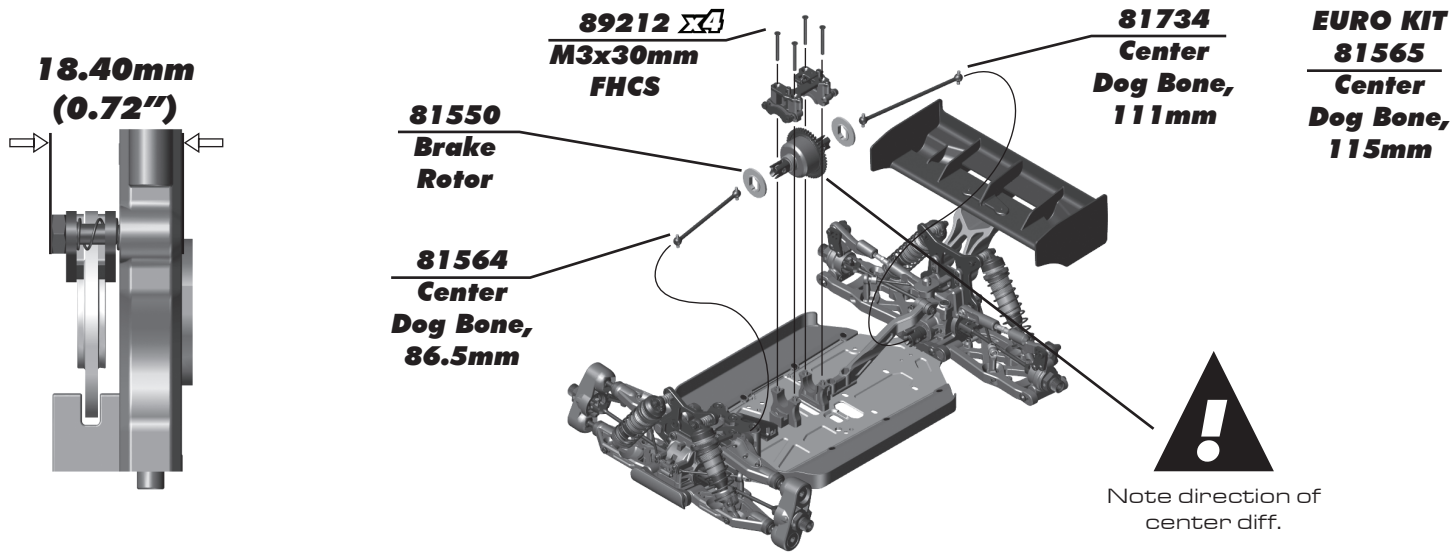

:: Linkages Build - Bag 10.1 - Step 1

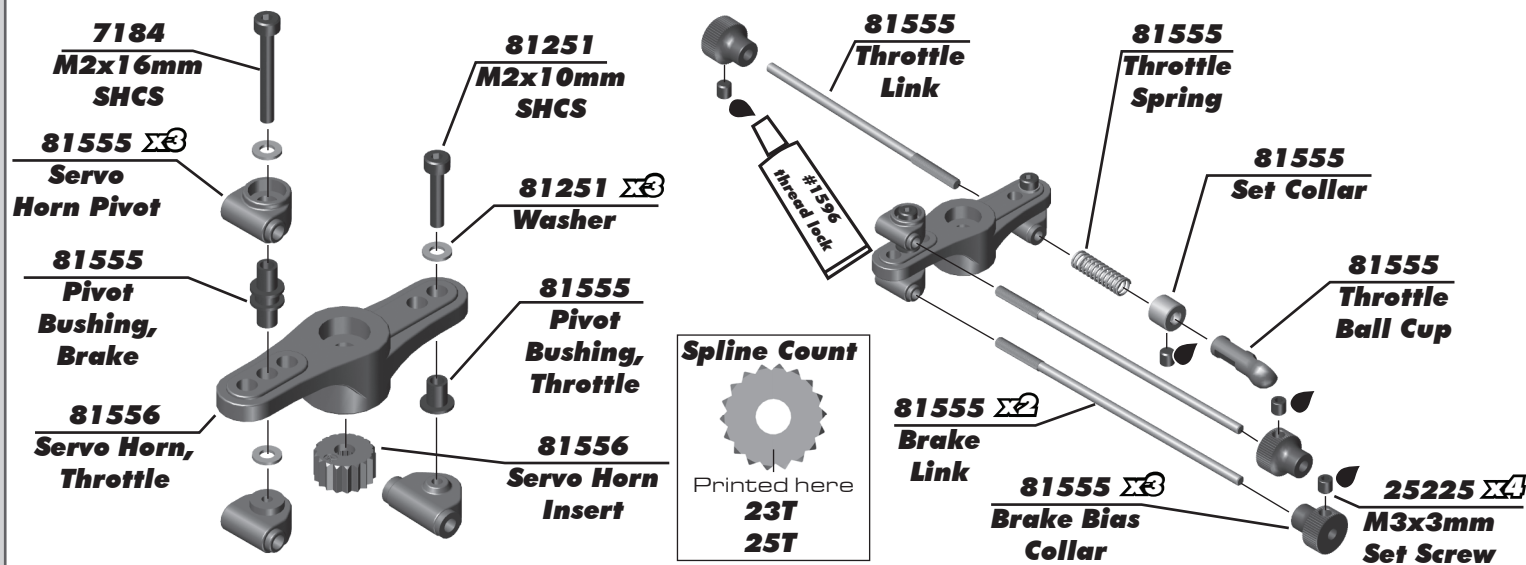

:: Linkages Build - Bag 10.1 - Step 2

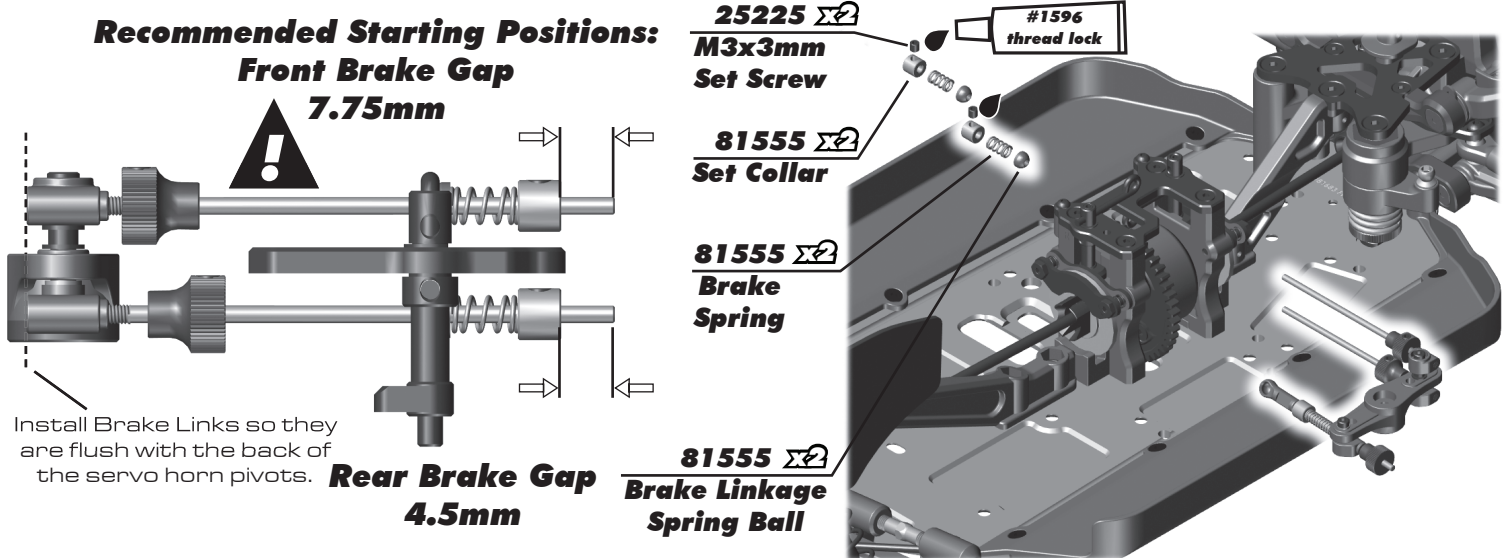

:: Linkages Build - Bag 10.1 - Step 3

Spline Count



Printed here
23T
25T

81556
Servo Horn
(Steering)

81556
Servo Horn
Insert

25215
M3
Locknut

91048
HD Ball
Stud, 8mm

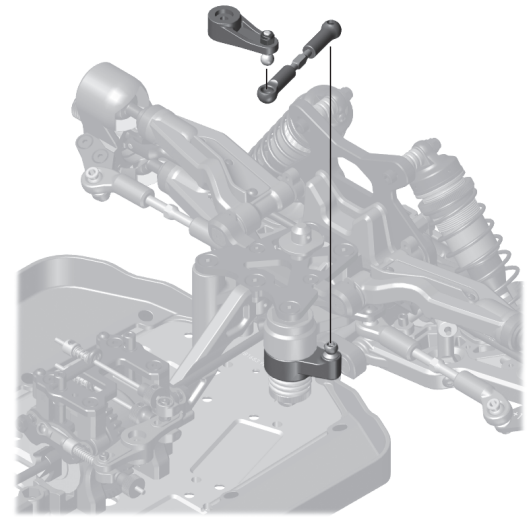

:: Radio Tray Build - Bag 11.1 - Step 1

Radio Tray Configuration:

The radio tray on RC8B4 can be configured in four different ways. Each configuration changes the amount and location of flex in the chassis. Experiment with different configurations when running on different surfaces.

When removing either graphite radio tray brace or transponder mount, utilize included plastic shims to maintain proper servo height.

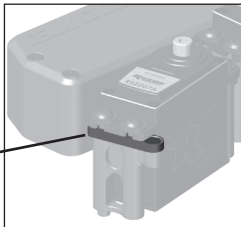

81433
Radio Tray
Spacer

Option 1

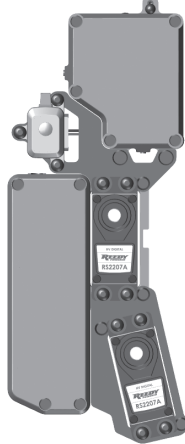

Least Flex
(Kit Setup)

Option 2

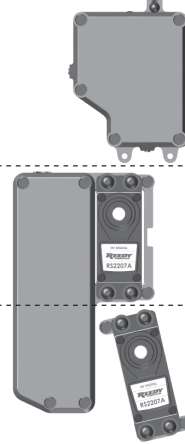

Most Flex

Option 3

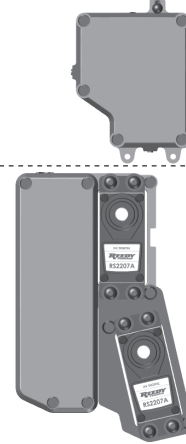

More Rearward
Flex

Option 4

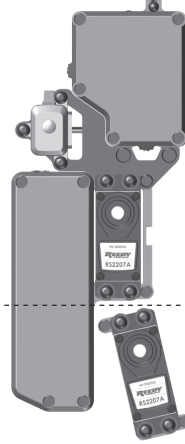

More Frontward
Flex

:: Radio Tray Build - Bag 11.1 - Step 2

31448 x4
2.5x8mm
FHCS

81592
FT Radio
Brace, RWB

41094 x4
3x14mm
LP SHCS

41094 x4
3x14mm
LP SHCS

81450
Transponder
Mount

81433 x2
Radio
Tray Post

Servo not included!

Servo not included!

25201 x2
3x8mm
FHCS

81432
Battery Box,
Bottom

81432
Receiver
Box, Bottom

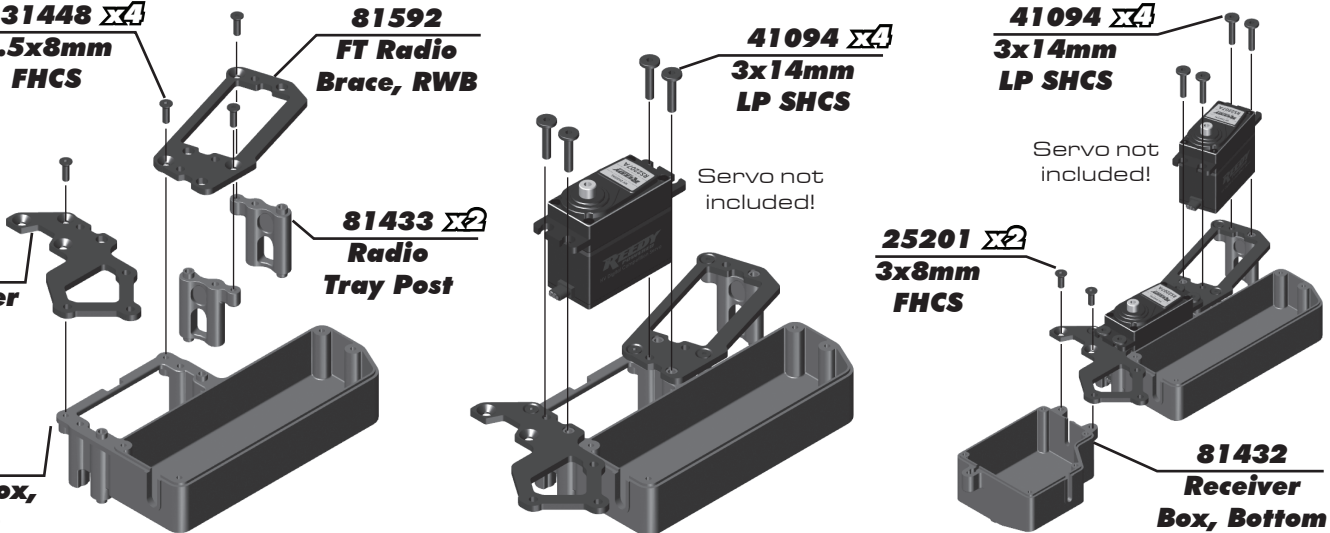

:: Radio Tray Build - Bag 11.1 - Step 3

42007 X2
Receiver Box Grommet

42007 X2
Grommet Plug

Receiver Battery not included!

Receiver not included!

6727
Servo Tape

31448 X9
2.5x8mm FHCS

81432
Receiver Box, Top

81432
Battery Box, Top

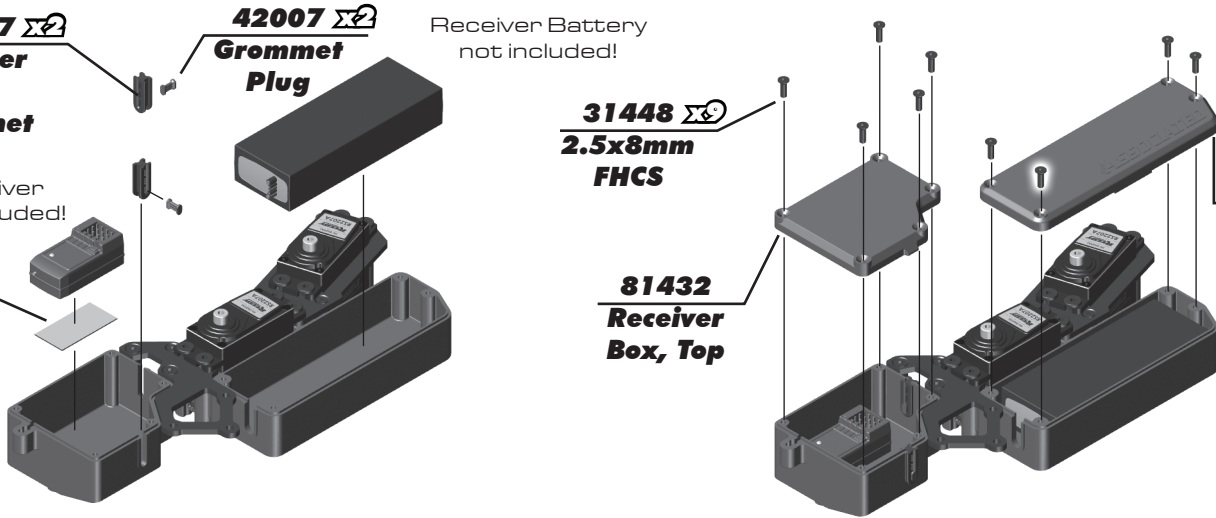

:: Radio Tray Build - Bag 11.1 - Step 4

25225
3x3mm Set Screw

25211 X3
3x10mm BHCS

On/Off switch not included!

6338
Antenna Tube and Cap

Transponder not included!

25215 X3
M3 Locknut

The switch and transponder positions can be reversed if desired



Install the electronics tray, then slide the servo horns onto the servos!



Racer's Tip:
Center servos before horn installation!

25211
3x10mm FHCS

#1596
thread lock

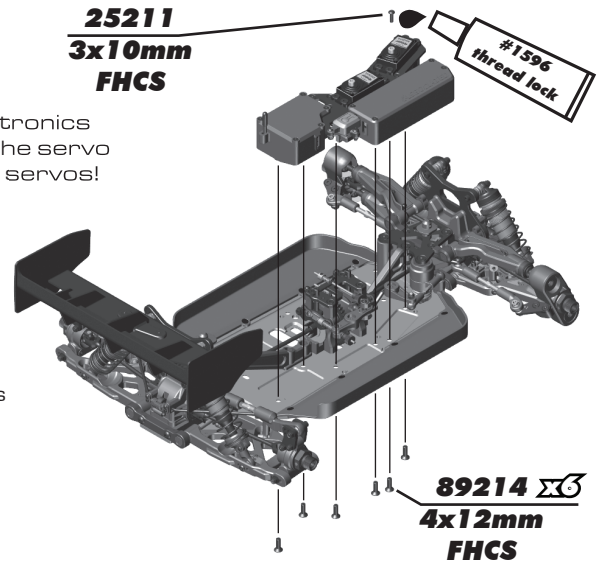

89214 X6
4x12mm FHCS

:: Radio Tray Build - Bag 11.1 - Step 5

Throttle Turnbuckle

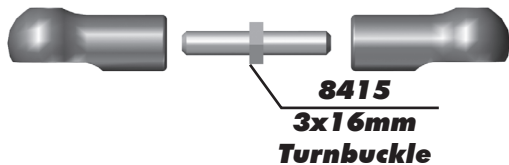

8415
3x16mm Turnbuckle

81521 X2
Ball Cup

7.15mm

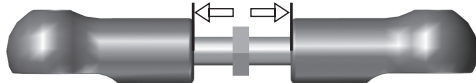

91048
HD Ballstud, 8mm Long

91049
HD Ball Stud, 10mm

31389
Washer
7.8x3.5x2mm
Blue Alum.

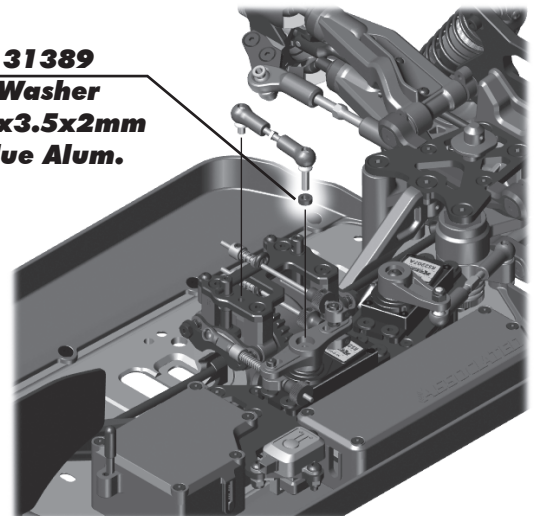

:: Clutch / Filter Build - Bag 12.1, 12.2 - Step 1

Engine not included!

81372 Flywheel Nut

81371 Flywheel Collet

81370 Flywheel, 4-Shoe

81373 Clutch Shoe Pins

See next step for clutch shoe/spring installation order!

Racer's Tip:
Use a small amount of blue threadlock on the crank, do not get it into the bearing!

:: Clutch / Filter Build - Bag 12.1, 12.2 - Step 2

Clutch Shoe / Spring Installation Order:

Short end of clutch shoe spring installed into flywheel.
Long end of clutch shoe spring installed into clutch shoe.

81402 Clutch Shoe, Composite

81366 Clutch Shoe Spring, Green, 0.95mm

81375 Clutch Shoes, Hard, 4-Shoe Aluminum

81367 Clutch Shoe Spring, Gold, 1.0mm

81366 Clutch Shoe Spring, Green, 0.95mm

81367 Clutch Shoe Spring, Gold, 1.0mm

81402 Clutch Shoe, Composite

:: Clutch / Filter Build - Bag 12.1, 12.2 - Step 3

Clutch shimming instructions:

- Build assembly with shims as shown
- If clutch bell does not spin freely:
Move shim from behind clutch bell to in front of clutch bell
- OR-
Remove one shim from front of clutch bell
- Recommended axial play in clutch bell = 0.2mm - 0.5mm

81374 Clutch Bell, 13T, Vented, 4-Shoe

89148 Clutch Shims

41089 3x6mm LP SHCS

91560 Bearing, 5x10x4mm

:: Clutch / Filter Build - Bag 12.1, 12.2 - Step 4

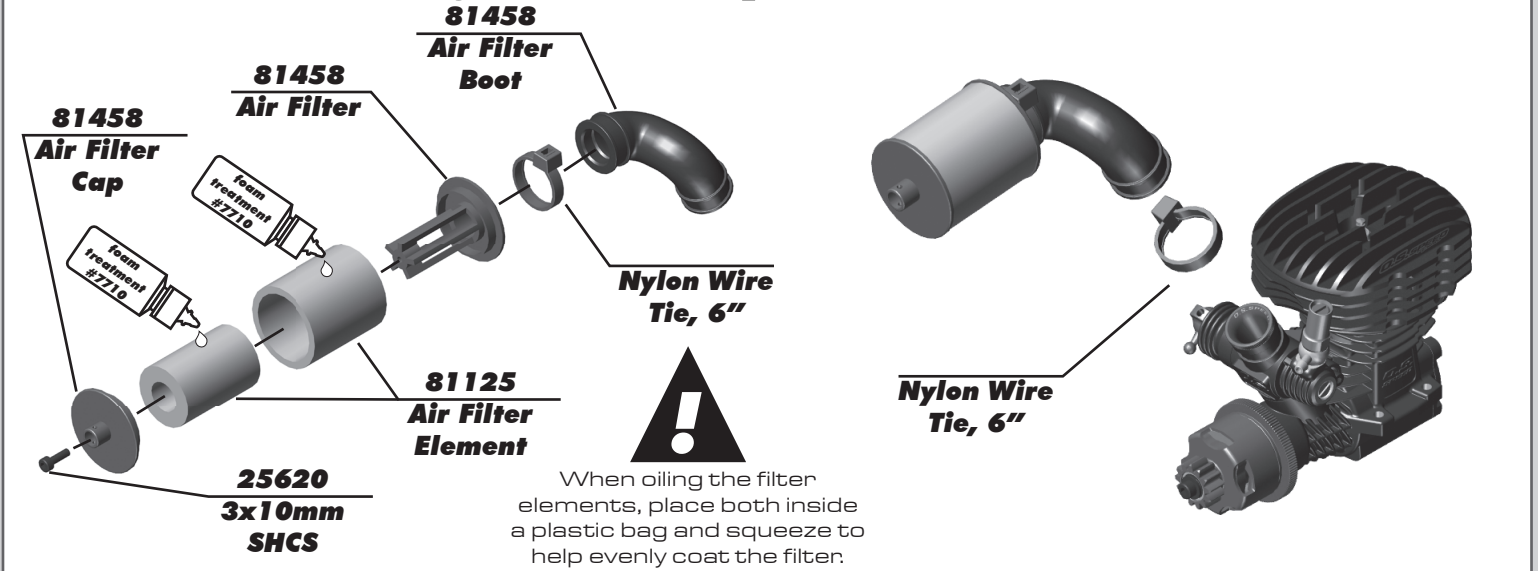

:: Clutch / Filter Build - Bag 12.1, 12.2 - Step 5

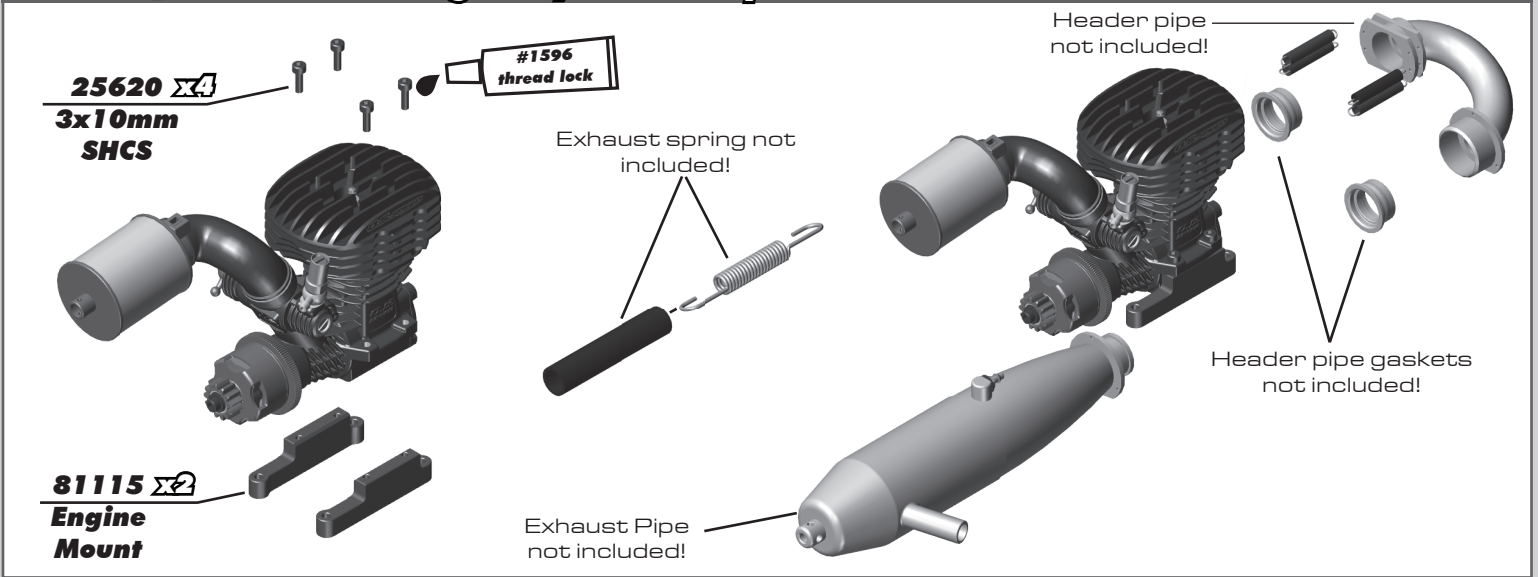

:: Clutch / Filter Build - Bag 12.1, 12.2 - Step 6

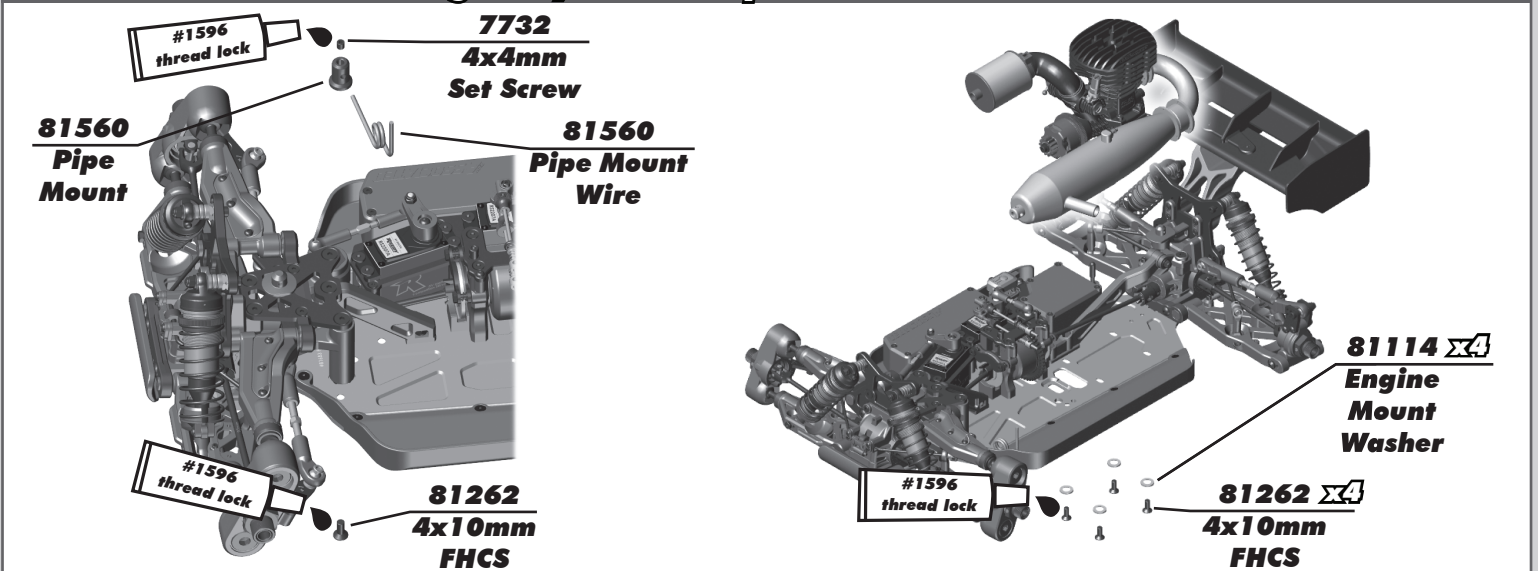

:: Clutch / Filter Build - Bag 12.1, 12.2 - Step 7



When installing your engine, make sure the rear drive shaft does not interfere with the engine block. You may need to remove material from the engine block for fitment.

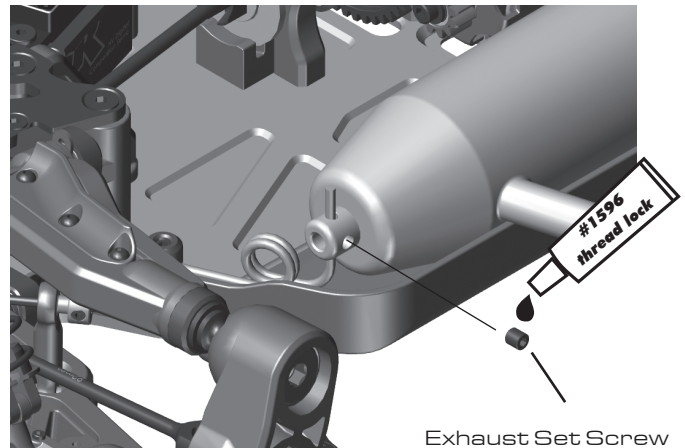
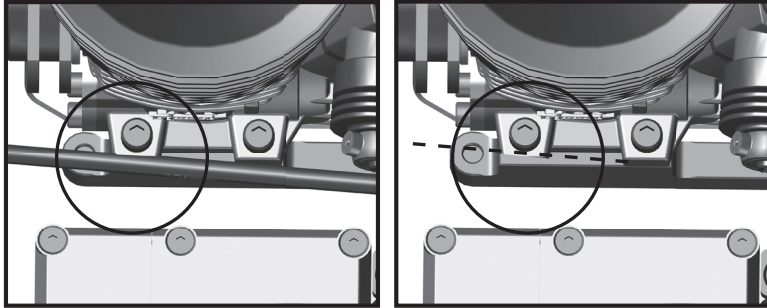

Exhaust Set Screw not included!

:: Fuel Tank Build - Bag 13.1, 13.2 - Step 1

41090 $\Sigma 2$
3x10mm LP SHCS

81558 $\Sigma 2$
Fuel Tank Grommet

2 **81557** $\Sigma 2$
Fuel Tank Post

81559
Fuel Tank Lid Puller

81557
Fuel Tank

81557 $\Sigma 2$
Fuel Tank Clip

89203 $\Sigma 2$
3x16mm BHCS

31520
2.5x6mm BHCS

7724
Fuel Tubing (Cut to 22mm long)

1 **81262** $\Sigma 2$
4x10mm FHCS

Racer's Tip:
Install fuel tank posts to chassis before installing the fuel tank.

:: Fuel Tank Build - Bag 13.1, 13.2 - Step 2

Pressure line from fuel tank lid to exhaust pipe

Fuel line from fuel tank to carburetor

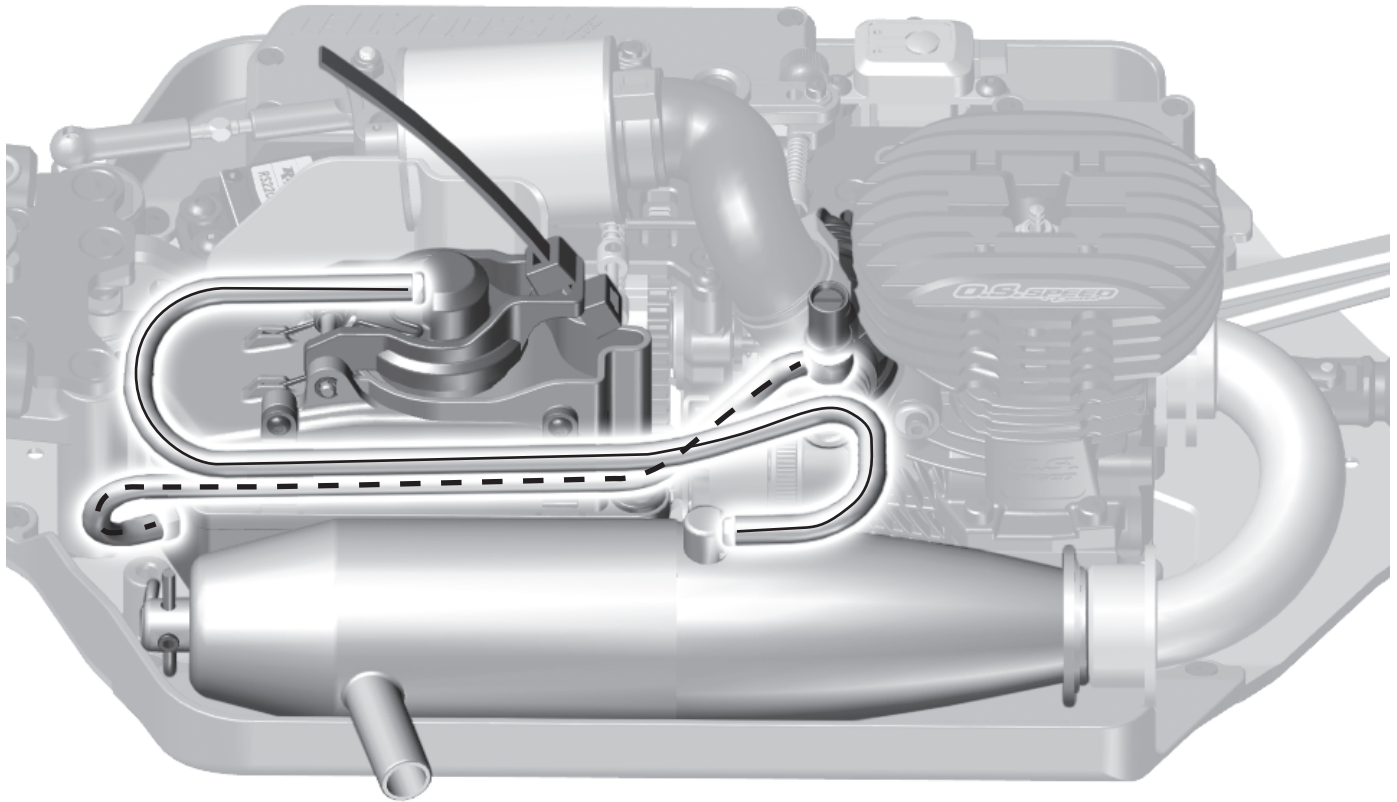

:: Wheels / Tires / Body - Misc. - Step 1



Wheels, Tires, and Foam Inserts Not Included!

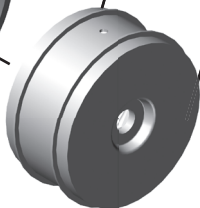
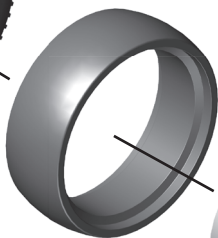

89296
RC8 Wheels,
white, 83mm

89297
RC8 Wheels,
yellow, 83mm

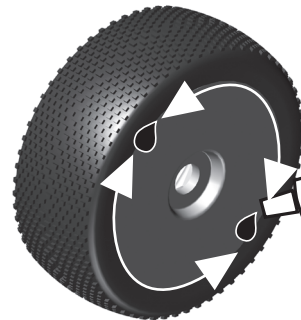

[not included]

#1597
CA tire glue



Build four
wheels/
tires

Tires:

When gluing tires to wheels, use a fast-curing tire glue (CA) [AE # 1597]. This is available at your local hobby shop. Make sure to clean the mounting surface of the tire and wheel with alcohol for best adhesion.

:: Wheels / Tires / Body - Misc. - Step 2



Install wheel nuts with the serrated edge towards the wheel.

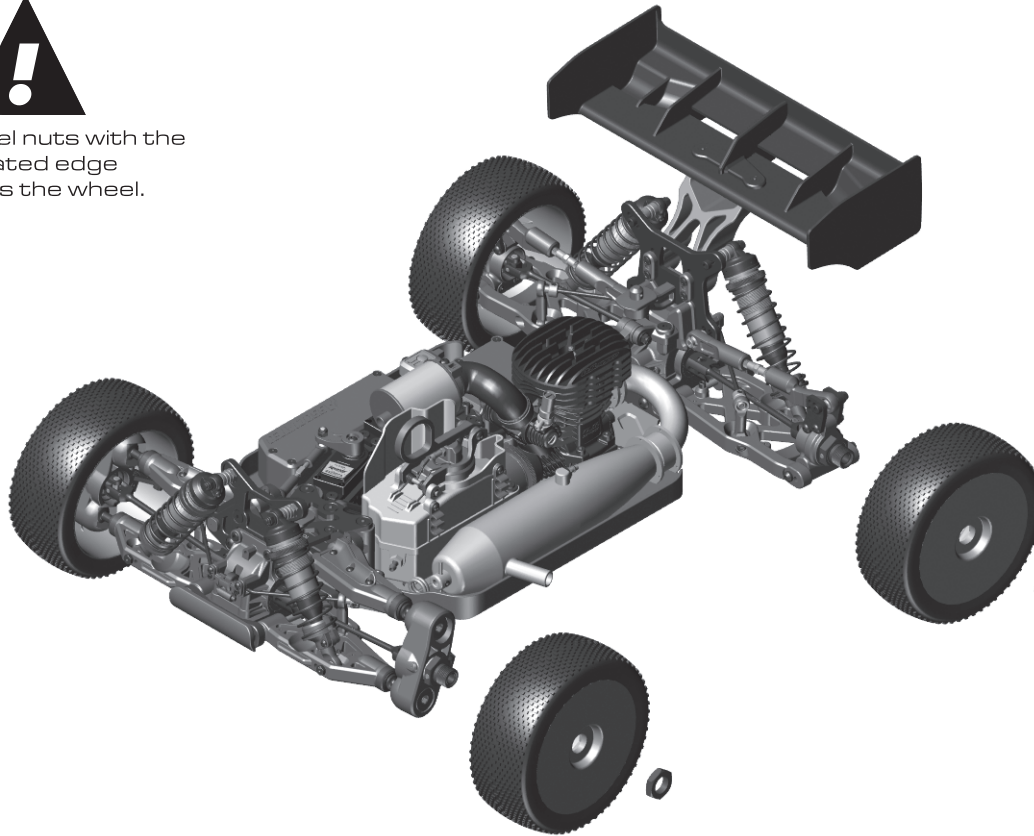

81082 X4
Wheel Nuts,
17mm
(Blue)

:: Wheels / Tires / Body - Misc. - Step 3



Final chassis ride height.
Front = 23mm
Rear = 26mm

2208 X2
Body Clip



81568
Body

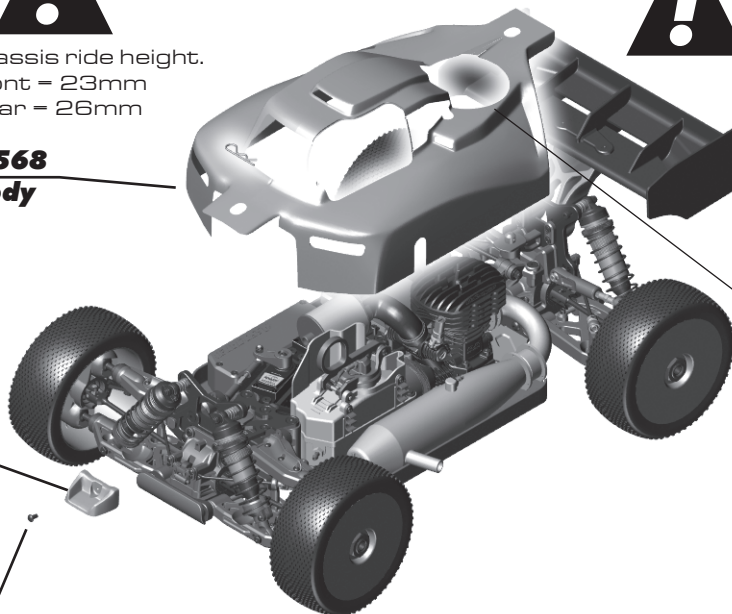

81568
Nose
Cone

31531
3x6mm
BHCS

Painting Tips:

Your kit comes with a clear polycarbonate body. You will need to prep the body before you can paint it. Wash the inside thoroughly with warm water and liquid detergent. Dry the body using a clean, soft, lint-free cloth. Install the window masks on the inside of the body. (RC cars get painted on the inside). Using high quality masking tape, apply tape to the inside of the body to create a design. Spray (either rattle can or airbrush RC specific paint) the paint to the inside of the body (preferably dark colors first, lighter colors last).

NOTE: use ONLY paint that is recommended for use with (polycarbonate) plastics. If you do not, you can destroy the polycarbonate body!

After painting, cut the body along the trim lines. Make sure to drill or use a body reamer to make the holes for the body mounts and antenna!



Kit RWB chassis uses the rear engine, tuning, and exhaust cutouts. Please check before trimming as your engine / pipe may vary.

:: Droop Settings

Set droop by measuring overall length of shock (from standoff to shock pin) while the chassis is elevated above your working surface. The shocks should be fully extended.

Kit setup for front droop is 101 mm shock length, and 126 mm shock length for the rear "C" hole.

If the shock length is too long, adjust by turning the droop screws clockwise.

If the shock length is too short, adjust by turning the droop screws counter-clockwise.

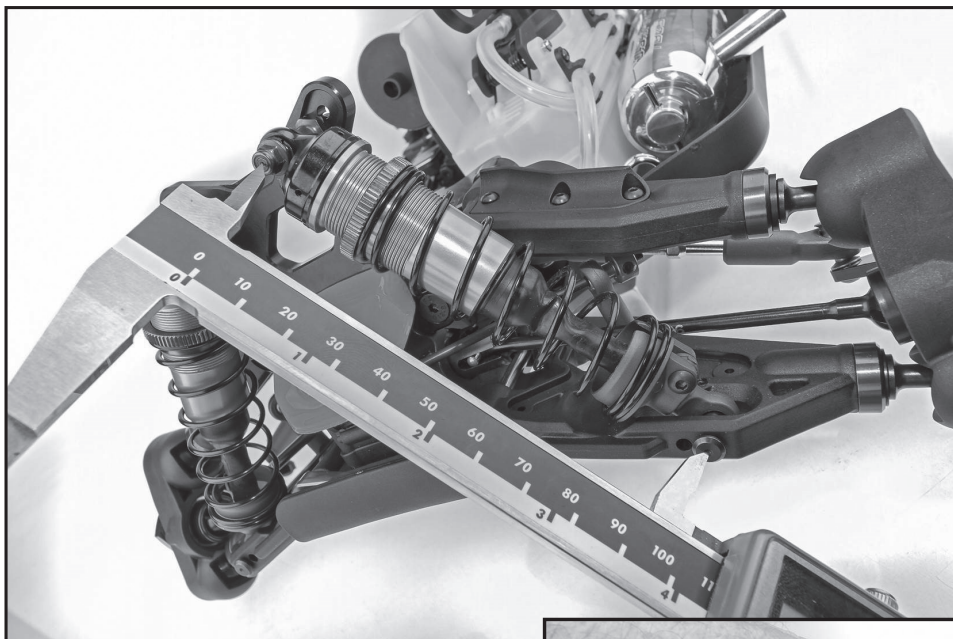

Racer's Tip:

Use 123mm for the middle "B" rear arm hole, and +2 or 0 eyelet.

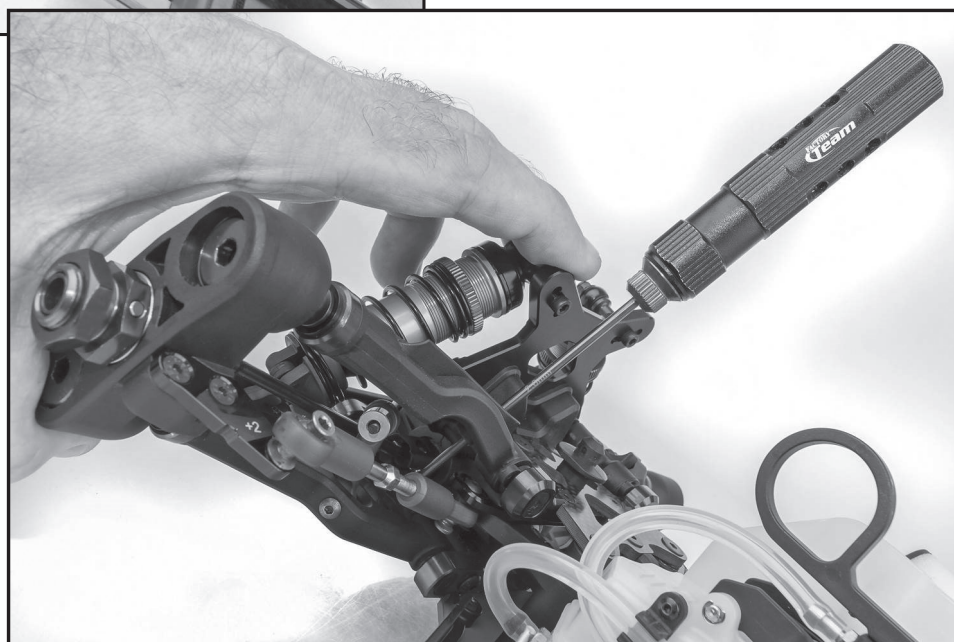

Front Droop: Increasing front droop (loosen droop screws) will increase off-throttle steering. It also allows the front end to lift more, giving more rear grip and less front grip on-power. Remember to never loosen the screws beyond the FULL DROOP setting. Decreasing front droop (tighten droop screws) yields more on-power steering and quicker response at the expense of some stability in bumpy sections. It will also give less off-throttle steering.

Rear Droop: Increasing rear droop (loosen droop screws) will increase traction in bumpy sections, but will reduce high-speed stability. Remember to never loosen the screws beyond the FULL DROOP setting. Decreasing rear droop (tighten droop screws) will increase stability in high speed sections, but will reduce stability in bumpy sections.

Setup Sheets:

To find different setups for your kit, visit our website, <https://www.associatedelectrics.com/teamassociated/> and click on the "Setup Sheets" link, and then the link to your model. Our team of professional drivers help develop these setups at races worldwide. Additionally, most drivers have a "base" setup that they use as a starting point for most races. Try running some of our base setups or look for track conditions and tires that are similar to your local track and replicate that setup. Remember, each adjustment has a purpose, so copy everything from the setup sheet and then make adjustments based on the recommendations in here.



Associated Electrics, Inc.
21062 Bake Parkway Lake Forest, CA 92630 USA

call: (949) 544-7500 - fax: (949) 544-7501
***Check out the following web sites for all of our kits, current products,
new releases, setup help, tips, and racing info!***
www.AssociatedElectrics.com

FOLLOW US ON SOCIAL MEDIA



TeamAssociated
ReedyPower
ElementRC
FactoryTeam51



@TeamAssociatedRC
@ReedyPower
@Element_RC
@FactoryTeam_RC



@Team_Associated
@ReedyPower



@Associated_Electrics



TeamAssociatedRC
ElementRC



TeamAssociated
Reedy
Element-rc