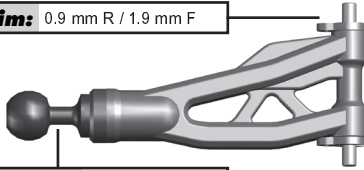
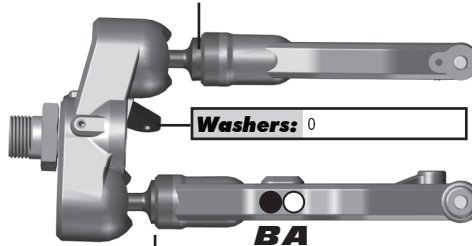

RESET
Front Suspension:

Ride Height: 27 mm
Camber: 0°
Toe: +2
Anti-Roll Bar
Size: 2.5 mm (White)
Gap: 2 mm
Ackerman
Notes: #81064 +2 Ackerman
1 2 3 4 5
Drive Shaft: CVAs: <input checked="" type="checkbox"/> Universals: <input type="checkbox"/>
Chassis Brace: Short: <input type="checkbox"/> Long: <input checked="" type="checkbox"/>
Hex: #89095 RC8.2 Hex (+1.5 mm)
Notes: 2mm Between Sway Bar Links

Caster Shim: 0.9 mm R / 1.9 mm F

Upper Ball Type: #81068 Aluminum

Upper Ball Shim: 0 mm

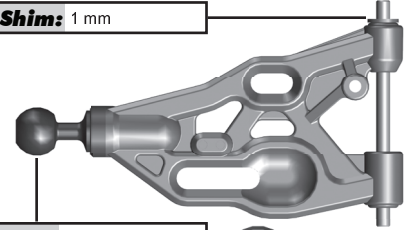
Washers: 0

BA
Lower Ball Shim: 0 mm

Wheelbase Shim: 1 mm

Lower Ball Type: #81068 Aluminum

Upper Arm Mount:

Arm Mount A:

Arm Mount B:

Rear Suspension:

Ride Height: 28 mm (Body Off)
Camber: -2°
Anti-Roll Bar
Size: 2.6 mm (Gray)
Gap: 0 mm
Drive Shaft: CVAs: <input checked="" type="checkbox"/> Universals: <input type="checkbox"/>
Chassis Brace: Short: <input checked="" type="checkbox"/> Long: <input type="checkbox"/>
Hex: +1
Notes: Sway Bar Link Moved Back 3mm In A-Arm #81077 FT Hubs (Pin Height Location = Middle)

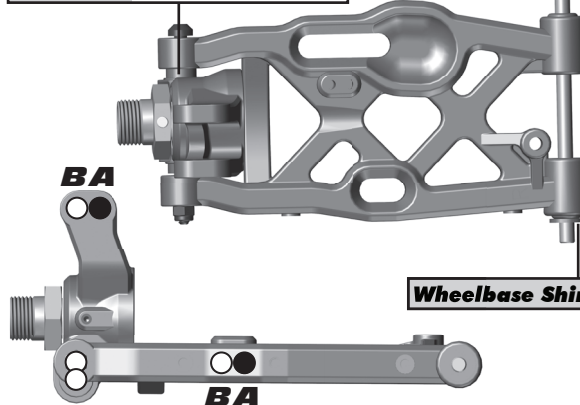
Hub Shim: 2.5 mm

BA
BA
Wheelbase Shim: 1 mm R / 0 mm F

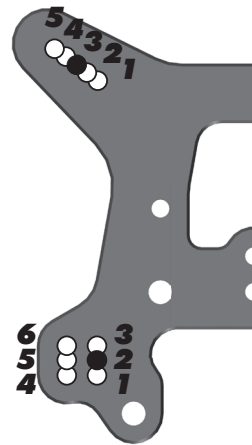
Arm Mount C:

Arm Mount D:

Electronics:

Radio: Sanwa M12S
Servo: Reedy RS1806A
EPA: Throttle: 95 % Brake: 70 %
EXPO: Throttle: 0 % Brake: 0 %
ESC: Hobbywing XR8PLUS / Software 4.0.53 / USBLink 4.0.1
Motor: #989 Reedy 2100 kv
Battery: #318 Reedy 6500 mAh
Notes: ESC Settings: Brake Force = 37.5%; Punch Level = 8; BEC Voltage = 7.4v; Dead Band = 6%; No Timing

Differential Fluid:

Front: 7,000 V1
Center: 20,000 V1
Rear: 3,000 V1 Rivkin / 4,000 V1 Cavalieri
Notes: Filled 1mm Above Cross Pins

Gearings:

Spur Gear: 46	Pinion: 16
Notes: Steel Spur Gear	

Shocks:

	Front	Rear
Piston:	6 x 1.3 Flat	6 x 1.3 Flat
Fluid:	35 wt	30 wt
Cap:	Emulsion	Emulsion
Rebound:	0 mm	0 mm
Spring:	8.75T/70mm	10.75T/86mm
Free Length:	104 mm	118 mm
Notes:		

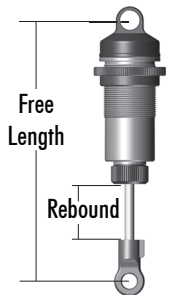
Track Info:

Size: Small <input type="checkbox"/> Medium <input type="checkbox"/> Large <input checked="" type="checkbox"/> Extra Large <input type="checkbox"/>
Surface: Dirt <input checked="" type="checkbox"/> Carpet <input type="checkbox"/> AstroTurf <input type="checkbox"/> Multi Surface <input type="checkbox"/>
Traction: Low <input type="checkbox"/> Medium <input checked="" type="checkbox"/> High <input type="checkbox"/> Very High <input type="checkbox"/>
Moisture: Dry <input checked="" type="checkbox"/> Damp <input type="checkbox"/> Wet <input type="checkbox"/>
Condition: Indoor <input type="checkbox"/> Outdoor <input checked="" type="checkbox"/> Dusty <input type="checkbox"/> Hard Packed <input type="checkbox"/> Bumpy <input checked="" type="checkbox"/> Grooved <input type="checkbox"/> Smooth <input type="checkbox"/> Loamy <input type="checkbox"/>
Temperature: Ambient: 90F Track: 100F
Notes:

Tires:

Front Tires: JConcepts Triple Dees / AKA Impact
Front Compound: Blue or Green / Super Soft or Soft
Front Insert: Closed Cell
Rear Tires: JConcepts Triple Dees / AKA Impact
Rear Compound: Blue or Green / Super Soft or Soft
Rear Insert: Closed Cell
Wheel (F/R): JConcepts / AKA
Notes:

Body, Wings:

Body: JConcepts Strike 2 / Team Associated Kit
Wing: JConcepts Hybrid Lexan
Wing Height: High: <input type="checkbox"/> Low: <input checked="" type="checkbox"/>
Gap to Tower: 19.5mm To Rear of Tower
Weight:
Total Vehicle Weight: 3572 g
Notes:

Vehicle Comments:
Notes: #81327 Aluminum CVA Axles;