

RESET

**Front Suspension:**

**Ride Height:** 25 mm

**Camber:** -1

**Toe:** +2 Out

**Anti-Roll Bar**

**Size:** 2.4 mm (Green)

**Gap:** 2 mm

**Ackerman**

1  
2  
3  
4  
5

**Notes:** 2mm Spacer Between Sway Bar Links; +2 Ackerman Plate With 1/2mm Under Ballstud; Short Chassis Brace; 5mm (+1) Hex;

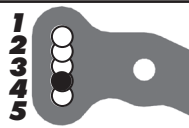
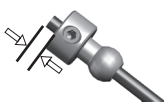

**Caster Shim:** 0.9 mm R / 2.9 mm F

**Upper Ball Type:** #81068 Aluminum

**Upper Ball Shim:** 0

**Lower Ball Shim:** 0

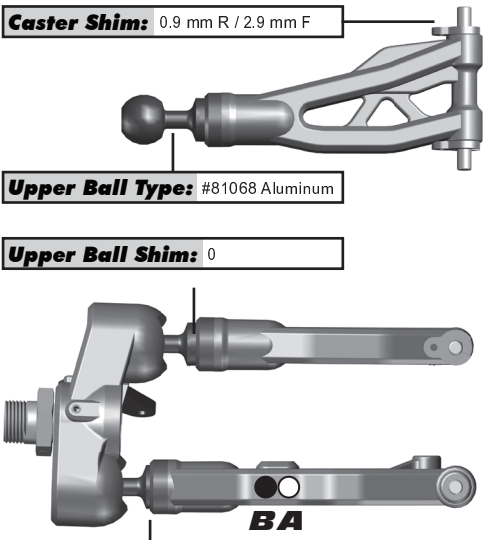

**Wheelbase Shim:** 2 mm R / 0 mm F

**Lower Ball Type:** #81068 Aluminum

**Upper Arm Mount:**

**Arm Mount A:**

**Arm Mount B:**

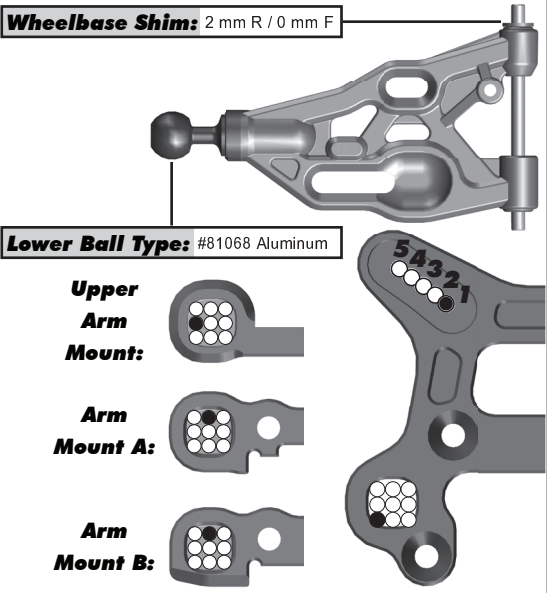

**Rear Suspension:**

**Ride Height:** 27 mm

**Camber:** -3

**Anti-Roll Bar**

**Size:** 2.7 mm (Gray)

**Gap:** 0

**Notes:** Reverse Sway Bar Pivot Ball; Sway Bar Mount Moved Back 3mm In A-Arm; 5mm (+1) Hex; #81301 Short Chassis Brace; Plastic Hubs; Carbon Fiber Tower; Rock Guards;

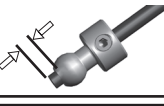

**Hub Shim:**

**Wheelbase Shim:**

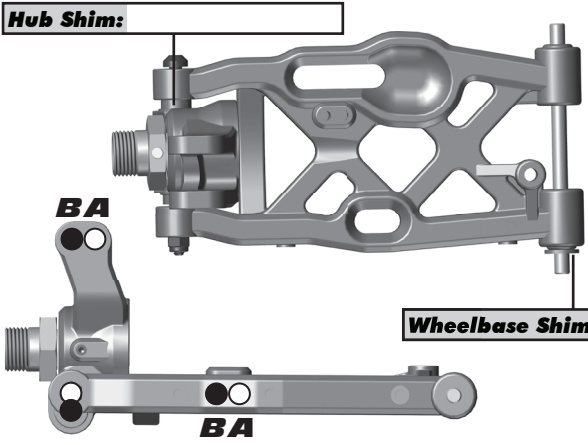

**Arm Mount C:**

**Arm Mount D:**

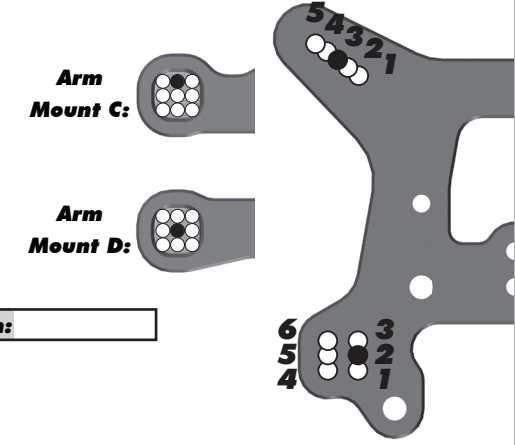

**Electronics:**

**Radio:**

**Servo:** Reedy RT2207A High Torque #27107

**EPA: Throttle:** 100 % **Brake:** 90 %

**EXPO: Throttle:** 0 % **Brake:** 0 %

**ESC:**

**Motor:** Reedy 2100 #989

**Battery:** Reedy 4600 mAh #311

**Notes:**

**Differential Fluid:**

**Front:** 7,000

**Center:** 15,000

**Rear:** 4,000

**Notes:** Filled 1mm above cross pins

**Shocks:**

	Front	Rear
<b>Piston:</b>	6 x 1.3 Flat	6 x 1.3 Flat
<b>Fluid:</b>	37.5 wt	32 wt
<b>Spring:</b>	Yellow (Cut 1 Coil)	Blue (Test Gray)
<b>Stroke:</b>	Flush With Threads	Flush With Threads
<b>Free Length:</b>	104 mm	120 mm
<b>Notes:</b>	Emulsion Shock	

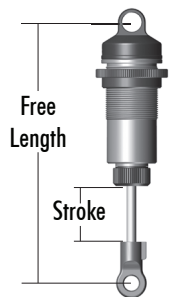

**Gearings:**

**Spur Gear:** 46 **Pinion:** 16

**Notes:**

**Track Info:**

**Size:** Small  Medium  Large  Extra Large

**Surface:** Dirt  Carpet  Astroturf  Multi Surface

**Traction:** Low  Medium  High  Very High

**Moisture:** Dry  Damp  Wet

**Condition:** Indoor  Outdoor  Dusty  Hard Packed   
Bumpy  Grooved  Smooth  Loamy

**Temperature:** Ambient: 75 Track: 70

**Notes:**

**Tires:**

**Front Tires:**

**Front Compound:**

**Front Insert:**

**Rear Tires:**

**Rear Compound:**

**Rear Insert:**

**Wheel (F/R):** Team Associated 83mm

**Notes:**

**Body, Wings:**

**Body:** Team Associated Stock

**Wing:** Team Associated Stock

**Wing Height:** High:  Low:

**Gap to Tower:** 28 mm

**Weight:**

**Total Vehicle Weight:**

**Notes:** #81274 Upper Titanium Screw Kit

**Vehicle Comments:**

**Notes:** Shave front of front a-arm 1mm to move a-arm forward & clearance for outdrive; CVAs