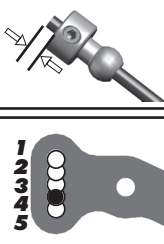

Front Suspension:

RESET

Ride Height: 26 mm
Camber: -1°
Toe: +1°
Anti-Roll Bar
Size: 2.3 mm (Black)
Gap: 1.8 mm
Ackerman
Notes: #81064 +2 Deg Steering Block Arms
Drive Shaft: CVAs: <input checked="" type="checkbox"/> Universals: <input type="checkbox"/>
Chassis Brace: Short: <input type="checkbox"/> Long: <input checked="" type="checkbox"/>
Hex: #81081 Kit, 5mm
Notes: 2 mm Spacer Between Sway Bar Links; #81026 Aluminum Shock Tower;

Caster Shim: 0.9 mm R / 2.9 mm F

Upper Ball Type: #81068 Aluminum

Upper Ball Shim: 0 mm

Washers: 0 mm

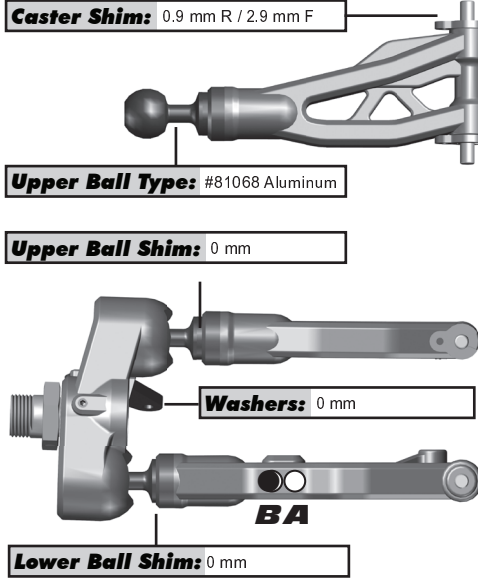
Lower Ball Shim: 0 mm

Wheelbase Shim: 0 mm F / 1 mm R

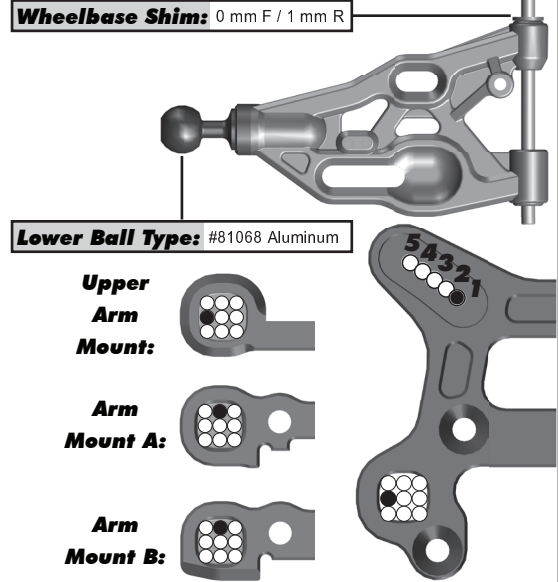
Lower Ball Type: #81068 Aluminum

Upper Arm Mount:
Arm Mount A:
Arm Mount B:

Rear Suspension:

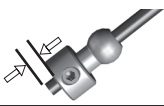
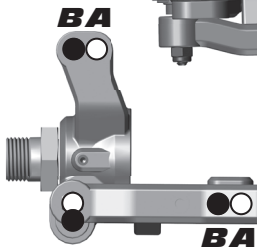
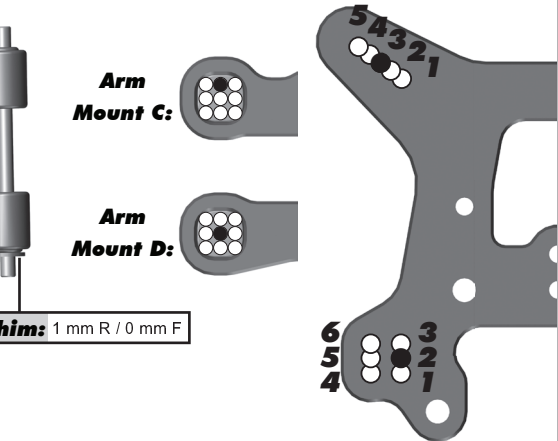
Ride Height: 27.5 mm
Camber: -2°
Anti-Roll Bar
Size: 2.7 mm (Blue)
Gap: 0 mm
Drive Shaft: CVAs: <input checked="" type="checkbox"/> Universals: <input type="checkbox"/>
Chassis Brace: Short: <input checked="" type="checkbox"/> Long: <input type="checkbox"/>
Hex: +1 mm, 6 mm
Notes: #81027 Aluminum Shock Tower; #81059 Mud Guards; #81075 Plastic Hub

Hub Shim: 2.5 mm R / 2.5 mm F

Arm Mount C:
Arm Mount D:
Wheelbase Shim: 1 mm R / 0 mm F

Electronics and Engine:

Radio: N/A
Receiver Battery: Reedy 2100 mAh #315
Throttle Servo: Reedy RS2207A
Steering Servo: Reedy RS2207A
EPA: Throttle: 50 % Brake: 48 %
Brake Bias: 45% F / 55% R D/R: 100 %
Engine: Mx B2R Temp: 245°
Muffler: O.S. 2090 Fuel: Mx 25%
Restrictor: 6 mm Glow Plug: O.S. P3

Differential Fluid:

Front: 7,000
Center: 10,000
Rear: 4,000
Notes: V1 Diffs; Team Associated Fluid

Clutch and Gearing:

Spur Gear: 46 Bell: 13
Shoes: N/A
Springs: N/A
Notes: N/A

Shocks:

	Front	Rear
Piston:	6 x 1.3 Flat Kit	6 x 1.3 Flat Kit
Fluid:	40 wt	35 wt
Cap:	Emulsion Bleeder	Emulsion Bleeder
Rebound:	0 mm	0 mm
Spring:	9.0 T / 70 mm	10.75 T / 86 mm
Free Length:	105 mm	121 mm
Notes:		

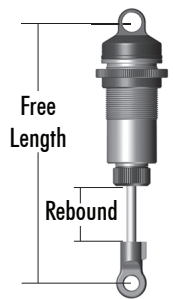

Track Info:

Size: Small <input type="checkbox"/> Medium <input type="checkbox"/> Large <input checked="" type="checkbox"/> Extra Large <input type="checkbox"/>
Surface: Dirt <input checked="" type="checkbox"/> Carpet <input type="checkbox"/> Astroturf <input type="checkbox"/> Multi Surface <input type="checkbox"/>
Traction: Low <input type="checkbox"/> Medium <input checked="" type="checkbox"/> High <input type="checkbox"/> Very High <input type="checkbox"/>
Moisture: Dry <input checked="" type="checkbox"/> Damp <input checked="" type="checkbox"/> Wet <input type="checkbox"/>
Condition: Indoor <input checked="" type="checkbox"/> Outdoor <input type="checkbox"/> Dusty <input checked="" type="checkbox"/> Hard Packed <input checked="" type="checkbox"/> Bumpy <input type="checkbox"/> Grooved <input checked="" type="checkbox"/> Smooth <input type="checkbox"/> Loamy <input type="checkbox"/>
Temperature: Ambient: 80° F Track: 80° F
Notes: Covered

Tires:

Front Tires: JConcepts Detox
Front Compound: Blue
Front Insert: JConcepts Dirt Tech
Rear Tires: JConcepts Detox
Rear Compound: Blue
Rear Insert: JConcepts Dirt Tech
Wheel (F/R): #89296 Team Associated 83 mm
Notes:

Body, Wings:

Body: JConcepts Strike 2
Wing: JConcepts Hybrid Lexan
Wing Height: High: <input type="checkbox"/> Low: <input checked="" type="checkbox"/>
Gap to Tower: 19.5 mm To Front Of The Tower
Weight:
Total Vehicle Weight: 3341g
Notes: #81274 Upper Titanium Screw Kit; 17g under center rear driveline

Vehicle Comments:

Notes: #81326 CVA Axles, Steel; #1363 Factory Team Aluminum Servo Horn 25T, 18.5 mm;