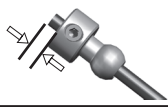
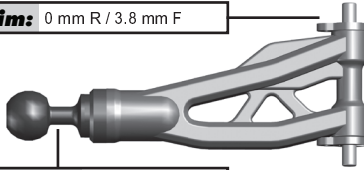
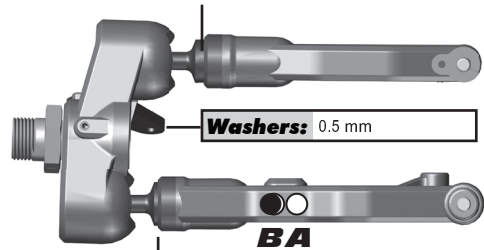

**RESET**

## Front Suspension:

<b>Ride Height:</b> 25 mm
<b>Camber:</b> -1/2
<b>Toe:</b> 0
<b>Anti-Roll Bar</b>
<b>Size:</b> 2.3 mm (Black)
<b>Gap:</b> 2.3 mm
<b>Ackerman</b>
<b>Notes:</b> #81064 +2 Steering Block Arms
<b>Drive Shaft:</b> CVAs: <input type="checkbox"/> Universals: <input checked="" type="checkbox"/>
<b>Chassis Brace:</b> Short: <input type="checkbox"/> Long: <input checked="" type="checkbox"/>
<b>Hex:</b> #81079 +1 mm
<b>Notes:</b> #81028 Carbon Fiber Shock Tower; #81085 Servo Saver Arm, Aluminum; 2mm Between Sway Bar Links; Updated Front Arm w/ Dot On Front Hinge Pin Boss

**Caster Shim:** 0 mm R / 3.8 mm F

**Upper Ball Type:** #81068 Aluminum

**Upper Ball Shim:** 1.4 mm

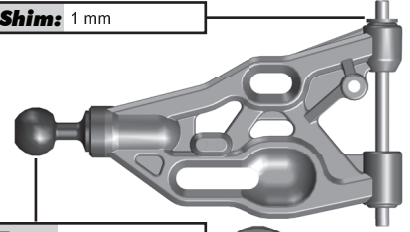
**Washers:** 0.5 mm

**BA**
**Lower Ball Shim:** 0.7 mm

**Wheelbase Shim:** 1 mm

**Lower Ball Type:** #81068 Aluminum

**Upper Arm Mount:**

**Arm Mount A:**

**Arm Mount B:**

## Rear Suspension:

<b>Ride Height:</b> 28 mm
<b>Camber:</b> -1/2
<b>Anti-Roll Bar</b>
<b>Size:</b> 2.7 mm (Blue)
<b>Gap:</b> 0 mm
<b>Drive Shaft:</b> CVAs: <input type="checkbox"/> Universals: <input checked="" type="checkbox"/>
<b>Chassis Brace:</b> Short: <input type="checkbox"/> Long: <input checked="" type="checkbox"/>
<b>Hex:</b> #81079 +1 mm
<b>Notes:</b> #81029 Carbon Fiber Shock Tower; #81059 Mud Guards; #81075 Plastic Rear Hubs; Updated Rear Arm w/ Dot In Front Of Sway Bar Link

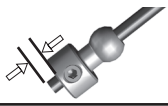
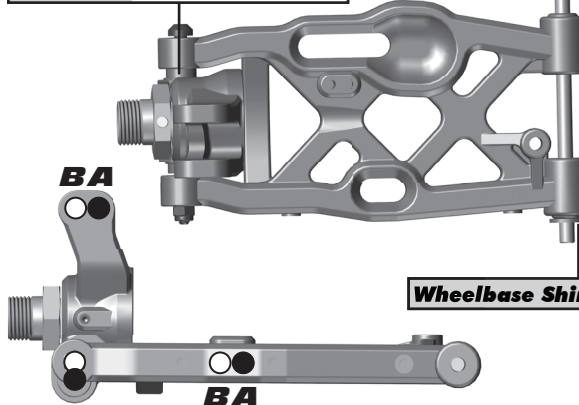
**Hub Shim:** 2.5 mm F / 2.5 mm R

**BA**
**Wheelbase Shim:** 1 mm R / 0 mm F

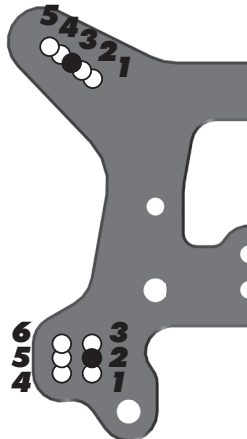
**Arm Mount C:**

**Arm Mount D:**

## Electronics and Engine:

<b>Radio:</b> Sanwa M12S
<b>Receiver Battery:</b> Team Orion 2500 mAh
<b>Throttle Servo:</b> Savox SB-2273
<b>Steering Servo:</b> Savox SB-2273
<b>EPA:</b> Throttle: N/A % Brake: N/A %
<b>Brake Bias:</b> 50F / 50R <b>D/R:</b> 100% %
<b>Engine:</b> Mx B2101 <b>Temp:</b> N/A
<b>Muffler:</b> O.S. 2090 SC <b>Fuel:</b> Mx 25% Dirt
<b>Restrictor:</b> 6.0 mm <b>Glow Plug:</b> O.S. P3

## Differential Fluid:

<b>Front:</b> 7,000 V1
<b>Center:</b> 6,000 V1
<b>Rear:</b> 4,000 V1
<b>Notes:</b> 2 Shims Behind Each Gear; No Gaskets

## Clutch and Gearing:

<b>Spur Gear:</b> 46 LW <b>Bell:</b> 13
<b>Shoes:</b> 2 x Aluminum + 2 x Carbon
<b>Springs:</b> 4 x 1.0
<b>Notes:</b>

## Shocks:

	Front	Rear
<b>Piston:</b>	8 x 1.2 Tapered	8 x 1.3 Tapered
<b>Fluid:</b>	40 wt	42.5 wt
<b>Cap:</b>	#81179 Bleeder	#81179 Bleeder
<b>Rebound:</b>	0 mm	0 mm
<b>Spring:</b>	9.0T	10.75T
<b>Free Length:</b>	104.5 mm	116.5 mm
<b>Notes:</b>	#81194 Shock Rod Ends & Spring Cups, 20mm; #81184 Bleeder Cap Seals; #81221 Spring Collars, 20mm	

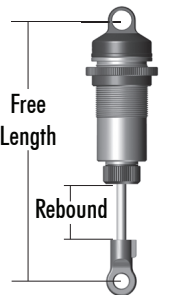

## Track Info:

<b>Size:</b> Small <input type="checkbox"/> Medium <input type="checkbox"/> Large <input checked="" type="checkbox"/> Extra Large <input type="checkbox"/>
<b>Surface:</b> Dirt <input checked="" type="checkbox"/> Carpet <input type="checkbox"/> AstroTurf <input type="checkbox"/> Multi Surface <input type="checkbox"/>
<b>Traction:</b> Low <input checked="" type="checkbox"/> Medium <input checked="" type="checkbox"/> High <input type="checkbox"/> Very High <input type="checkbox"/>
<b>Moisture:</b> Dry <input checked="" type="checkbox"/> Damp <input type="checkbox"/> Wet <input type="checkbox"/>
<b>Condition:</b> Indoor <input type="checkbox"/> Outdoor <input checked="" type="checkbox"/> Dusty <input checked="" type="checkbox"/> Hard Packed <input checked="" type="checkbox"/> Bumpy <input checked="" type="checkbox"/> Grooved <input type="checkbox"/> Smooth <input type="checkbox"/> Loamy <input type="checkbox"/>
<b>Temperature:</b> Ambient: 80F Track: 80F
<b>Notes:</b>

## Tires:

<b>Front Tires:</b> AKA Double Down
<b>Front Compound:</b> Soft
<b>Front Insert:</b> AKA Red
<b>Rear Tires:</b> AKA Double Down
<b>Rear Compound:</b> Soft
<b>Rear Insert:</b> AKA Red
<b>Wheel (F/R):</b> AKA
<b>Notes:</b>

## Body, Wings:

<b>Body:</b> JConcepts Prototype
<b>Wing:</b> Pro-Line Lexan V2
<b>Wing Height:</b> High: <input type="checkbox"/> Low: <input checked="" type="checkbox"/>
<b>Gap to Tower:</b> 22 mm
<b>Weight:</b>
<b>Total Vehicle Weight:</b> 3321g
<b>Notes:</b>

## Vehicle Comments:

**Notes:** #81274 Upper Titanium Screw Kit