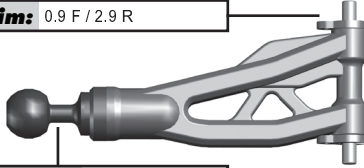
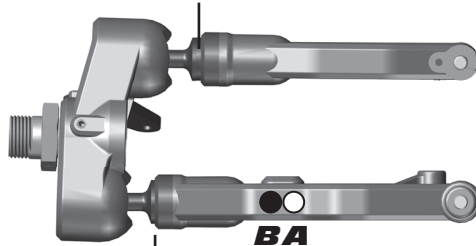
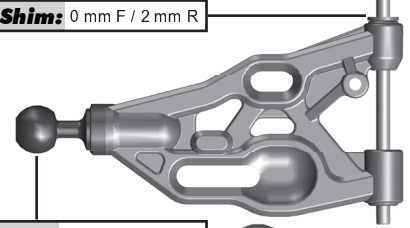

RESET
Front Suspension:

Ride Height: 26 mm
Camber: N/A
Toe: + 1/2
Anti-Roll Bar
Size: 2.3 mm (Black)
Gap: 2.3 mm
Ackerman
1 2 3 4 5
Notes: #81064 Steering Block Arm +2 Deg; #89095 Hex; #81029 Carbon Front Shock Tower; #81301 Short Chassis Brace; #81327 Aluminum CVA Axles; #81330 CVA Bone 2mm Spacer Between Sway Bar Links 1mm Removed From Front of A-Arm

Caster Shim: 0.9 F / 2.9 R

Upper Ball Type: #81068 Aluminum

Upper Ball Shim: 0

Lower Ball Shim: 0

Wheelbase Shim: 0 mm F / 2 mm R

Lower Ball Type: #81068 Aluminum

Upper Arm Mount:

Arm Mount A:

Arm Mount B:

Rear Suspension:

Ride Height: 28 mm
Camber: -3
Anti-Roll Bar
Size: 2.7 mm (Blue)
Gap: 0 mm
Notes: #89095 Hex; #81029 Carbon Rear Shock Tower; #81301 Short Chassis Brace; #81327 Aluminum CVA Axle; #81329 CVA Bone Sway Bar Link Moved 2mm Back In A-Arm

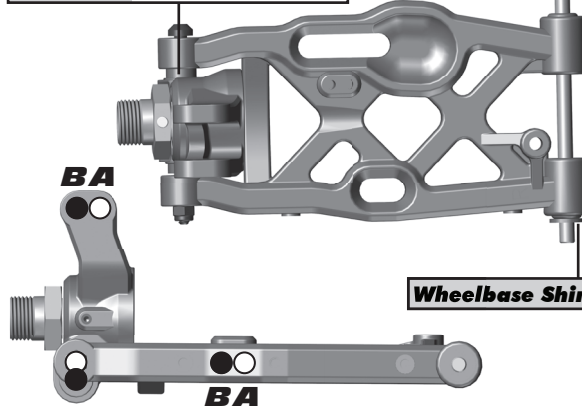
Hub Shim: 2.5 mm

Arm Mount C:

Arm Mount D:

Wheelbase Shim: 0 mm F / 1 mm R

Electronics and Engine:

Radio: Airtronics M12
Receiver Battery: LRP 2500 mAh
Throttle Servo: MKS
Steering Servo: MKS
EPA: Throttle: N/A % Brake: N/A %
Brake Bias: 50 / 50 D/R: 100 %
Engine: LRP Temp: N/A
Muffler: O.S. 2090 Fuel: Flashpoint 30%
Restrictor: 6.5 mm Glow Plug: LRP

Differential Fluid:

Front: 7,000
Center: 7,000
Rear: 4,000
Notes: V1 Diffs

Clutch and Gearing:

Spur Gear: 46	Bell: 13
Shoes: 2 Aluminum / 2 Carbon	
Springs: 1.0	
Notes: 4 Shoe Clutch	

Shocks:

	Front	Rear
Piston:	6 x 1.3 Flat	6 x 1.3 Flat
Fluid:	40 wt	35 wt
Spring:	9.0T	10.75T
Stroke:	N/A	N/A
Free Length:	105 mm	121 mm
Notes:	Emulsion Shock	

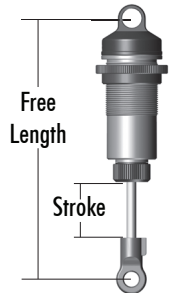
Track Info:

Size: Small <input type="checkbox"/> Medium <input type="checkbox"/> Large <input checked="" type="checkbox"/> Extra Large <input type="checkbox"/>
Surface: Dirt <input checked="" type="checkbox"/> Carpet <input type="checkbox"/> Astroturf <input type="checkbox"/> Multi Surface <input type="checkbox"/>
Traction: Low <input type="checkbox"/> Medium <input checked="" type="checkbox"/> High <input type="checkbox"/> Very High <input type="checkbox"/>
Moisture: Dry <input type="checkbox"/> Damp <input checked="" type="checkbox"/> Wet <input type="checkbox"/>
Condition: Indoor <input type="checkbox"/> Outdoor <input checked="" type="checkbox"/> Dusty <input type="checkbox"/> Hard Packed <input type="checkbox"/> Bumpy <input checked="" type="checkbox"/> Grooved <input type="checkbox"/> Smooth <input type="checkbox"/> Loamy <input type="checkbox"/>
Temperature: Ambient: _____ Track: _____
Notes:

Tires:

Front Tires: Pro-Line Switch Blade
Front Compound: X3
Front Insert: Pro-Line
Rear Tires: Pro-Line Switch Blade
Rear Compound: X3
Rear Insert: Pro-Line
Wheel (F/R): Pro-Line
Notes:

Body, Wings:

Body: Team Associated Kit
Wing: Team Associated Kit
Wing Height: High: <input type="checkbox"/> Low: <input checked="" type="checkbox"/>
Gap to Tower: Wing Moved 10mm Back
Weight:
Total Vehicle Weight: N/A
Notes:

Vehicle Comments:
Notes: #81274 Upper Titanium Screw Kit