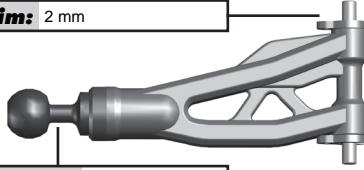
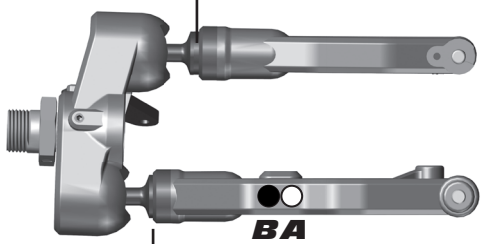
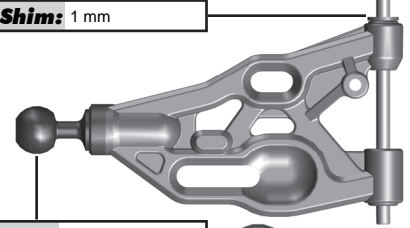

Front Suspension:
RESET

Ride Height: 27 mm
Camber: -1
Toe: +2
Anti-Roll Bar
Size: 2.4 mm
Gap: 1 mm
Ackerman
1 2 3 4 5
Notes: Servo saver gap 1mm

Caster Shim: 2 mm

Upper Ball Type: Aluminum

Upper Ball Shim: 1 mm

Lower Ball Shim: 0.5 mm

Wheelbase Shim: 1 mm

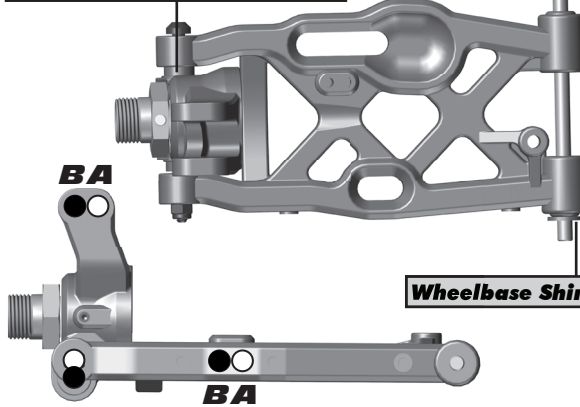
Lower Ball Type: Aluminum

Upper Arm Mount:
Arm Mount A:
Arm Mount B:
Rear Suspension:

Ride Height: 28 mm
Camber: -2
Anti-Roll Bar
Size: 2.7 mm
Gap: 1 mm
Notes: No mud flaps
#81301 Short chassis brace

Hub Shim: Middle

Arm Mount C:
Arm Mount D:
Wheelbase Shim: 1 mm

Electronics and Engine:

Radio: Airtronics M12
Receiver Battery: Reedy #304 1800 mAh
Throttle Servo: Reedy #27101 1208
Steering Servo: Reedy #27101 1208
EPA: Throttle: 42 % Brake: 50 %
Brake Bias: F45/R55 D/R: 100 %
Engine: O.S. B2101 Temp: N/A
Muffler: OS 2090 Fuel: VP 30%
Restrictor: 6.0 mm Glow Plug: P3

Differential Fluid:

Front: 10,000 AE
Center: 15,000 AE
Rear: 7,000 AE
Notes:

Shocks:

	Front	Rear
Piston:	8 x 1.3 Flat	8 x 1.3 Flat
Fluid:	40 wt. AE	35 wt. AE
Spring:	Blue	Blue
Stroke:	N/A	N/A
Free Length:	105 mm	125.5 mm
Notes:	Shock eyelets unscrewed 2 mm and droop screw pocket recessed	

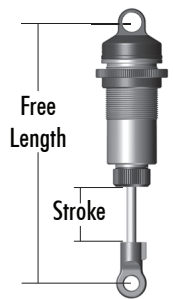
Clutch and Gearing:

Spur Gear: 46 Bell: 13
Shoes: 2 x Aluminum + 2 x Carbon
Springs: 4 x 1.0
Notes:

Track Info:

Size: Small <input type="checkbox"/> Medium <input type="checkbox"/> Large <input checked="" type="checkbox"/> Extra Large <input checked="" type="checkbox"/>
Surface: Dirt <input checked="" type="checkbox"/> Carpet <input type="checkbox"/> Astroturf <input type="checkbox"/> Multi Surface <input type="checkbox"/>
Traction: Low <input type="checkbox"/> Medium <input checked="" type="checkbox"/> High <input type="checkbox"/> Very High <input type="checkbox"/>
Moisture: Dry <input checked="" type="checkbox"/> Damp <input type="checkbox"/> Wet <input type="checkbox"/>
Condition: Indoor <input type="checkbox"/> Outdoor <input checked="" type="checkbox"/> Dusty <input checked="" type="checkbox"/> Hard Packed <input checked="" type="checkbox"/> Bumpy <input type="checkbox"/> Grooved <input checked="" type="checkbox"/> Smooth <input checked="" type="checkbox"/> Loamy <input type="checkbox"/>
Temperature: Ambient: 100 Track: 115
Notes:

Tires:

Front Tires: JConcepts Reflex
Front Compound: Y2
Front Insert: JConcepts Dirt Tech
Rear Tires: JConcepts Reflex
Rear Compound: Y2
Rear Insert: JConcepts Dirt Tech
Wheel (F/R): Team Associated #89297
Notes:

Body, Wings:

Body: Team Associated Kit
Wing: RC8B3 Kit
Wing Height: High: <input type="checkbox"/> Low: <input checked="" type="checkbox"/>
Gap to Tower: 19 mm to rear of tower
Weight:
Total Vehicle Weight: 3310g
Notes:

Vehicle Comments:
Notes: Team Associated Titanium Screw Kit #81274; OFNA aluminum steering servo horn: