

Front Suspension:

RESET

Ride Height: 25 mm

Camber: -1°

Toe: +3°

Anti-Roll Bar

Size: 2.4 mm (Green)

Gap: 2 mm

Ackerman

Notes: #81079 FT Steering Block Arm +2 Deg, Aluminum

Drive Shaft: CVAs: Universals:

Chassis Brace: Short: Long:

Hex: #81079 Wheel Hex, +1 mm

Notes: #81028 FT Carbon Fiber Shock Tower

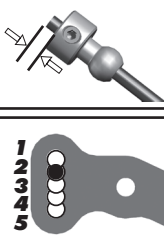

Caster Shim: 0 mm F / 4.0 mm R

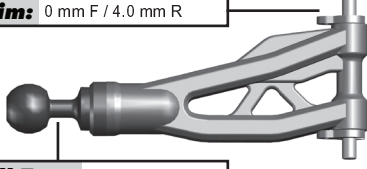

Upper Ball Type: #81068 Aluminum

Upper Ball Shim: 0

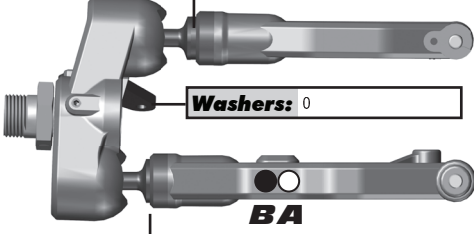

Washers: 0

BA

Lower Ball Shim: 0

Wheelbase Shim: 0 mm F / 1 mm R

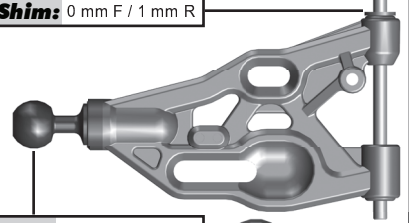

Lower Ball Type: #81068 Aluminum

Upper Arm Mount:

Arm Mount A:

Arm Mount B:



Rear Suspension:

Ride Height: 28.5 mm

Camber: -1.5°

Anti-Roll Bar

Size: 2.7 mm (Blue)

Gap: 0 mm

Drive Shaft: CVAs: Universals:

Chassis Brace: Short: Long:

Hex: #81079 Wheel Hex, +1 mm

Notes: #81029 FT Carbon Fiber Shock Tower
FastRace +5 mm Shock Standoffs

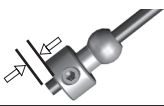

Hub Shim: 2.5 mm F / 2.5 mm R

Wheelbase Shim: 1 mm F / 0 mm R

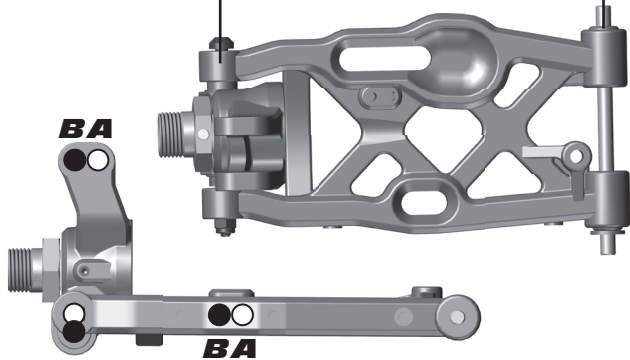

BA

BA

Arm Mount C:

Arm Mount D:

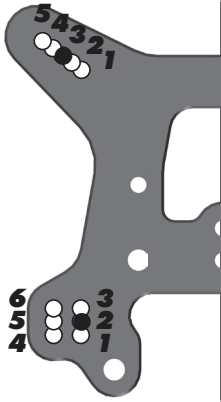

Electronics:

Radio: Sanwa M12S

Servo: #27107 Reedy RT2207A

EPA: Throttle: 100 % Brake: 70 %

EXPO: Throttle: 0 % Brake: 0 %

ESC: Hobbywing XR8PLUS / Software 4.0.53 / USBLink 4.0.1

Motor: #989 Reedy 2100 kV

Battery: #318 Reedy 6500 mAh

Notes: ESC: Brake Force = 37.5%; Punch Level = 8; BEC = 7.4v
Dead Band = 6%; Drag Brake = 0%; No Timing; Battery Cutoff = Disabled

Differential:

	Fluid	Gear Set	Planet O-Rings
Front:	7,000	HTC	0
Center:	10,000	HTC	0
Rear:	4,000	HTC	0

Gearing:

Spur Gear: 46 **Pinion:** 15

Notes:

Shocks:

	Front	Rear
Piston:	8 x 1.2 Tapered	8 x 1.3 Tapered
Fluid:	42.5 wt	32.5 wt
Cap:	FastRace	FastRace
Rebound:	10 mm	10 mm
Spring:	Blue V2	Blue V2
Free Length:	105 mm	123.25 mm
Notes:	#81174 & #81175 FT Chrome Shock Shafts; #81164 & #81165 Fox Shock Bodies; #81407 FT Shock Seal Bushings	
	Set	

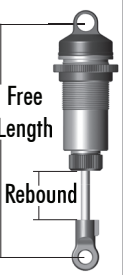

Track Info:

Size: Small Medium Large Extra Large

Surface: Dirt Carpet Astroturf Multi Surface

Traction: Low Medium High Very High

Moisture: Dry Damp Wet

Condition: Indoor Outdoor Dusty Hard Packed
Bumpy Grooved Smooth Loamy

Temperature: Ambient: 65F Track: 65F

Notes: Track was bumpy for Neo

Tires:

Front Tires: JConcepts Dirt Webs

Front Compound: Gold

Front Insert: JConcepts Dirt Tech

Rear Tires: JConcepts Dirt Webs

Rear Compound: Gold

Rear Insert: JConcepts Dirt Tech

Wheel (F/R): JConcepts Mono

Notes:

Body, Wings:

Body: JConcepts S3

Wing: #81108 Team Associated Kit / JConcepts Front Nose Scoop

Wing Height: High: Low:

Gap to Tower: Stock Location

Weight:

Total Vehicle Weight: ~3450g

Notes:

Vehicle Comments:

Notes: #81274 Upper Titanium Screw Kit