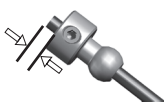
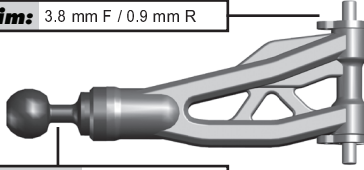
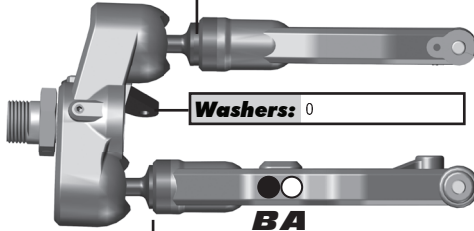

## Front Suspension:

<b>Ride Height:</b> 25 mm
<b>Camber:</b> -1°
<b>Toe:</b> +3°
<b>Anti-Roll Bar</b>
<b>Size:</b> 2.4 mm (Green)
<b>Gap:</b> 2 mm
<b>Ackerman</b>
<b>Notes:</b> #81079 FT Steering Block Arm +2 Deg, Aluminum
<b>Drive Shaft:</b> CVAs: <input checked="" type="checkbox"/> Universals: <input type="checkbox"/>
<b>Chassis Brace:</b> Short: <input checked="" type="checkbox"/> Long: <input type="checkbox"/>
<b>Hex:</b> #81079 Wheel Hex, +1 mm
<b>Notes:</b> #81028 FT Carbon Fiber Shock Tower #81085 FT Servo Saver Arm, Aluminum

**Caster Shim:** 3.8 mm F / 0.9 mm R

**Upper Ball Type:** #81068 Aluminum

**Upper Ball Shim:** 0

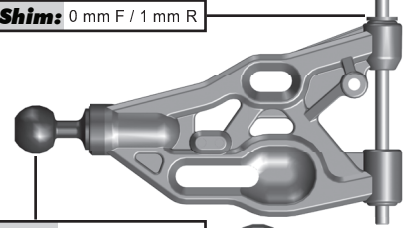
**Washers:** 0

**Lower Ball Shim:** 0

**Wheelbase Shim:** 0 mm F / 1 mm R

**Lower Ball Type:** #81068 Aluminum

**Upper Arm Mount:**

**Arm Mount A:**

**Arm Mount B:**

## Rear Suspension:

<b>Ride Height:</b> 28 mm
<b>Camber:</b> -1.5°
<b>Anti-Roll Bar</b>
<b>Size:</b> 2.7 mm (Blue)
<b>Gap:</b> 0 mm
<b>Drive Shaft:</b> CVAs: <input checked="" type="checkbox"/> Universals: <input type="checkbox"/>
<b>Chassis Brace:</b> Short: <input type="checkbox"/> Long: <input checked="" type="checkbox"/>
<b>Hex:</b> #81079 Wheel Hex, +1 mm
<b>Notes:</b> #81029 FT Carbon Fiber Shock Tower

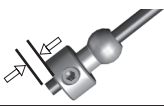
**Hub Shim:** 2.5 mm F / 2.5 mm R

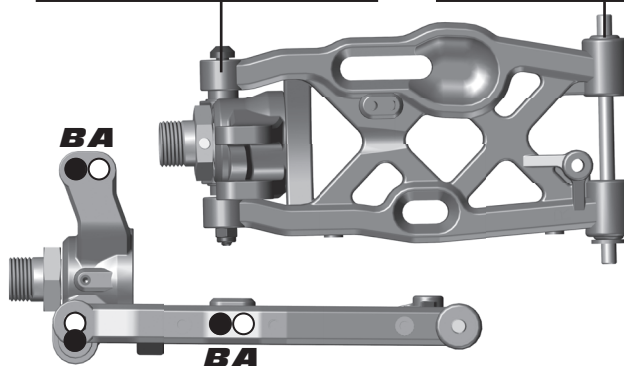
**Wheelbase Shim:** 1 mm F / 0 mm R

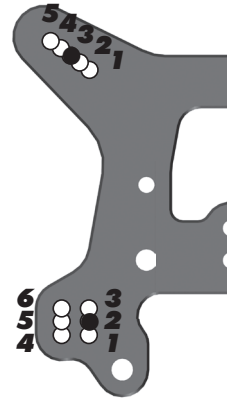
**Arm Mount C:**

**Arm Mount D:**

## Electronics:

<b>Radio:</b> Sanwa M12S
<b>Servo:</b> Savox
<b>EPA:</b> Throttle: 100 % Brake: 70 %
<b>EXPO:</b> Throttle: 0 % Brake: 0 %
<b>ESC:</b> Muchmore
<b>Motor:</b> #989 Reedy 2100 kV
<b>Battery:</b> Muchmore
<b>Notes:</b>

## Differential:

	Fluid	Gear Set	Planet O-Rings
<b>Front:</b>	7,000	HTC	0
<b>Center:</b>	10,000	HTC	0
<b>Rear:</b>	3,000	HTC	0

## Gearing:

<b>Spur Gear:</b> 46	<b>Pinion:</b> 15
<b>Notes:</b>	

## Shocks:

	Front	Rear
<b>Piston:</b>	8 x 1.3 Flat	8 x 1.3 Tapered
<b>Fluid:</b>	42.5 wt	32.5 wt
<b>Cap:</b>	Bleeder	Bleeder
<b>Rebound:</b>	0 mm	0 mm
<b>Spring:</b>	Blue V2	Gray V2
<b>Free Length:</b>	104 mm	122.5 mm
<b>Notes:</b>	#81174 & #81175 FT Chrome Shock Shafts; #81164 & #81165 Fox Shock Bodies; #81407 FT Shock Seal Bushings	
	Set	



## Track Info:

<b>Size:</b> Small <input type="checkbox"/> Medium <input type="checkbox"/> Large <input checked="" type="checkbox"/> Extra Large <input type="checkbox"/>
<b>Surface:</b> Dirt <input checked="" type="checkbox"/> Carpet <input type="checkbox"/> AstroTurf <input type="checkbox"/> Multi Surface <input type="checkbox"/>
<b>Traction:</b> Low <input type="checkbox"/> Medium <input type="checkbox"/> High <input checked="" type="checkbox"/> Very High <input type="checkbox"/>
<b>Moisture:</b> Dry <input checked="" type="checkbox"/> Damp <input type="checkbox"/> Wet <input type="checkbox"/>
<b>Condition:</b> Indoor <input checked="" type="checkbox"/> Outdoor <input type="checkbox"/> Dusty <input type="checkbox"/> Hard Packed <input checked="" type="checkbox"/> Bumpy <input checked="" type="checkbox"/> Grooved <input type="checkbox"/> Smooth <input type="checkbox"/> Loamy <input type="checkbox"/>
<b>Temperature:</b> Ambient: 65F Track: 65F
<b>Notes:</b> Track was bumpy for Neo

## Tires:

<b>Front Tires:</b> JConcepts Barcodes
<b>Front Compound:</b> Gold
<b>Front Insert:</b> JConcepts Dirt Tech
<b>Rear Tires:</b> JConcepts Barcodes
<b>Rear Compound:</b> Gold
<b>Rear Insert:</b> JConcepts Dirt Tech
<b>Wheel (F/R):</b> JConcepts Mono
<b>Notes:</b>

## Body, Wings:

<b>Body:</b> JConcepts S3
<b>Wings:</b> #81108 Team Associated Kit / JConcepts Front Nose Scoop
<b>Wing Height:</b> High: <input checked="" type="checkbox"/> Low: <input type="checkbox"/>
<b>Gap to Tower:</b> Stock Location
<b>Weight:</b>
<b>Total Vehicle Weight:</b> ~3450g
<b>Notes:</b>

## Vehicle Comments:

**Notes:** #81274 Upper Titanium Screw Kit