

RESET

Front Suspension:

Ride Height: 24 mm
Camber: 0°
Toe: +2°
Anti-Roll Bar
Size: 2.4 mm (Green)
Gap: 0.5 mm
Ackerman
Notes:
Drive Shaft: CVAs: <input checked="" type="checkbox"/> Universals: <input type="checkbox"/>
Chassis Brace: Short: <input type="checkbox"/> Long: <input checked="" type="checkbox"/>
Hex: #81079 Wheel Hex, +1 mm
Notes:

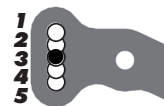
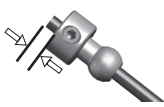
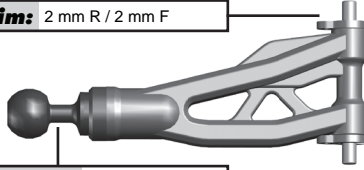
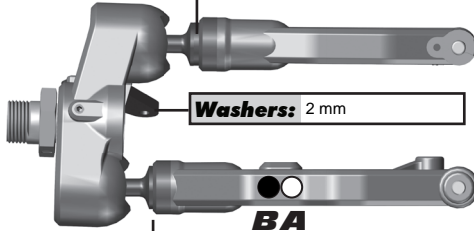

Caster Shim: 2 mm R / 2 mm F

Upper Ball Type: #81067 Steel

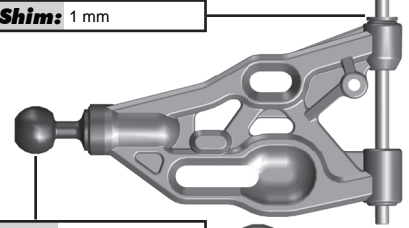
Upper Ball Shim: 0.35 mm

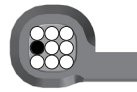
Washers: 2 mm

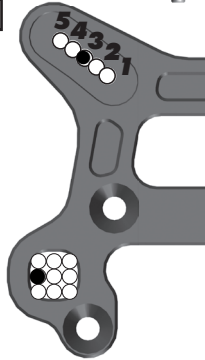
BA
Lower Ball Shim: 0 mm

Wheelbase Shim: 1 mm

Lower Ball Type: #81067 Steel

Upper Arm Mount:

Arm Mount A:

Arm Mount B:

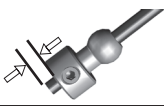
Rear Suspension:

Ride Height: 27 mm
Camber: 0°
Anti-Roll Bar
Size: 2.7 mm (Blue)
Gap: 0.5 mm (Ball Reversed)
Drive Shaft: CVAs: <input checked="" type="checkbox"/> Universals: <input type="checkbox"/>
Chassis Brace: Short: <input type="checkbox"/> Long: <input checked="" type="checkbox"/>
Hex: #81079 Wheel Hex, +1 mm
Notes:

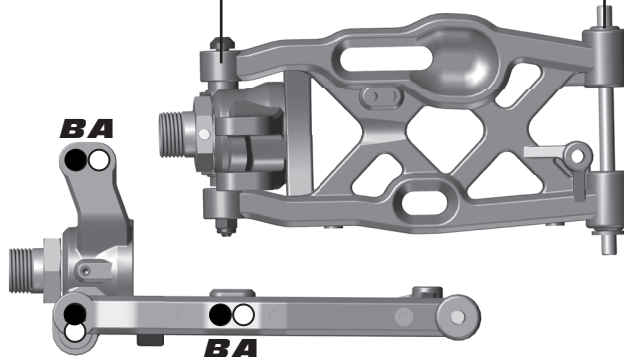
Hub Shim: 1 mm R / 4 mm F

Wheelbase Shim: 1 mm

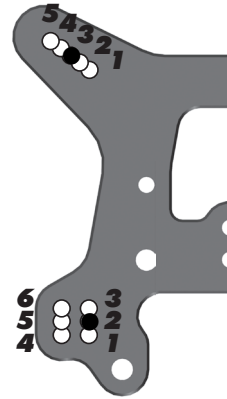
BA
BA
Arm Mount C:

Arm Mount D:

Electronics:

Radio: Sanwa M12S
Servo: Sanwa PGS-XB
EPA: Throttle: 90 % Brake: 85 %
EXPO: Throttle: -10 % Brake: -15 %
ESC: LRP iX8 V2
Motor: LRP Dynamic 2400 kV
Battery: LRP 8000 mAh Graphine
Notes:

Differential:

	Fluid	Gear Set	Planet O-Rings
Front:	10,000	HTC	No
Center:	7,000	HTC	No
Rear:	4,000	HTC	No

Gearing:

Spur Gear: 46	Pinion: 14
Notes:	

Shocks:

	Front	Rear
Piston:	8 x 1.2 Kyosho	8 x 1.3 Kyosho
Fluid:	400	400
Cap:	FastRace	FastRace
Rebound:	0	0
Spring:	Mugen 9.25T/70mm	Mugen 10.75T/86 mm
Free Length:	105 mm	116 mm
Notes:		

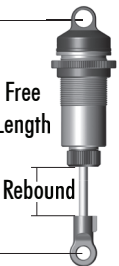

Track Info:

Size: Small <input type="checkbox"/> Medium <input type="checkbox"/> Large <input type="checkbox"/> Extra Large <input checked="" type="checkbox"/>
Surface: Dirt <input checked="" type="checkbox"/> Carpet <input type="checkbox"/> Astroturf <input type="checkbox"/> Multi Surface <input type="checkbox"/>
Traction: Low <input type="checkbox"/> Medium <input type="checkbox"/> High <input checked="" type="checkbox"/> Very High <input type="checkbox"/>
Moisture: Dry <input checked="" type="checkbox"/> Damp <input type="checkbox"/> Wet <input type="checkbox"/>
Condition: Indoor <input type="checkbox"/> Outdoor <input checked="" type="checkbox"/> Dusty <input checked="" type="checkbox"/> Hard Packed <input checked="" type="checkbox"/> Bumpy <input type="checkbox"/> Grooved <input checked="" type="checkbox"/> Smooth <input type="checkbox"/> Loamy <input type="checkbox"/>
Temperature: Ambient: _____ Track: _____
Notes:

Tires:

Front Tires: AKA Catapult
Front Compound: Super Soft
Front Insert: AKA Red
Rear Tires: AKA Catapult
Rear Compound: Super Soft
Rear Insert: AKA Red
Wheel (F/R): AKA
Notes:

Body, Wings:

Body: JConcepts Silencer
Wing: Hot Bodies
Wing Height: High: <input checked="" type="checkbox"/> Low: <input type="checkbox"/>
Gap to Tower: AE Kit Location
Weight:
Total Vehicle Weight:
Notes:

Vehicle Comments:

Notes:
